

STATE OF ILLINOIS
DEPARTMENT OF TRANSPORTATION

ROUTE NO.	SECTION	COUNTY	SHEETS	SHEET	SHEET NO. 4 of 9 SHEETS
FAP 721	114BR-2	DEWITT	64	32	
FED. ROAD DIST. NO. 5		ILLINOIS	FED. AID PROJECT		

CONTRACT NO. 70014

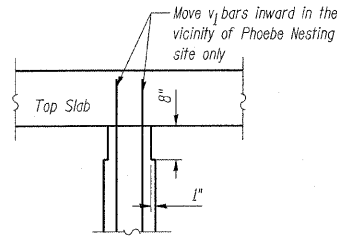

PHOEBE NESTING NOTCH DETAIL

Note: Notch formed by rough-finished board attached to and removed with formwork. Do not chamfer. (Downstream end only.)

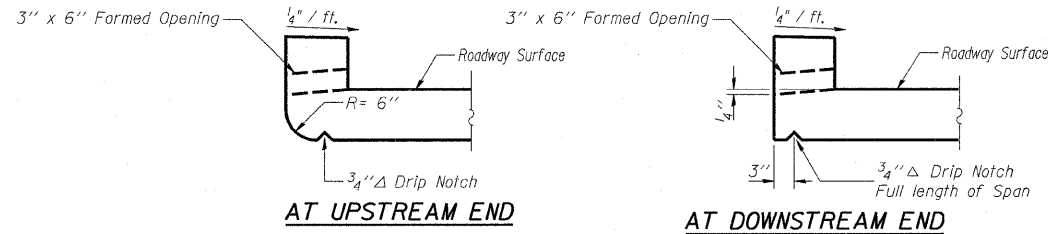

DRAIN DETAIL

Locate one formed opening near center of each barrel. Allow 1'-0" min. clear to nearest guardrail post base plate.

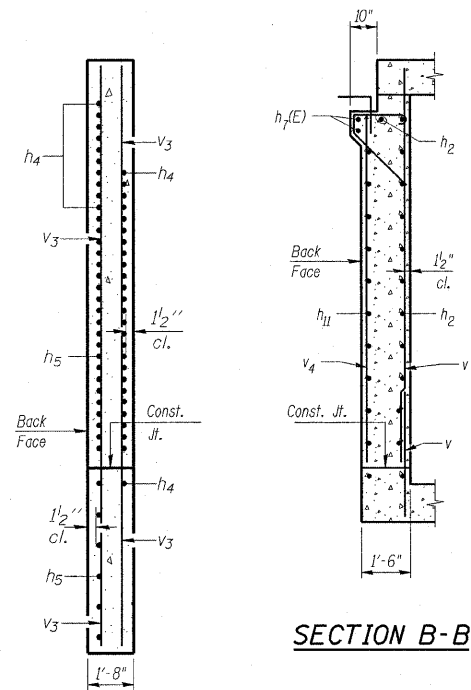

SECTION A-A

SECTION B-B

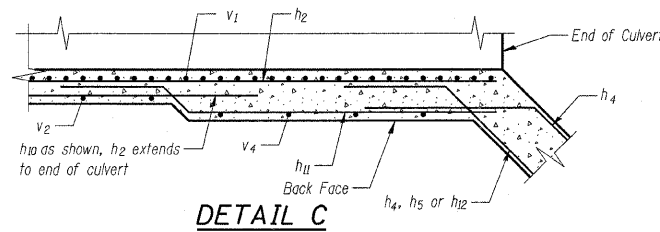

DETAIL C

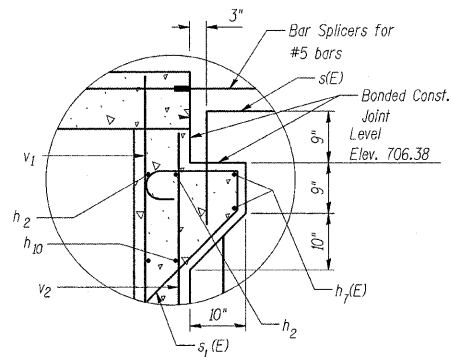

PAVEMENT LEDGE DETAIL

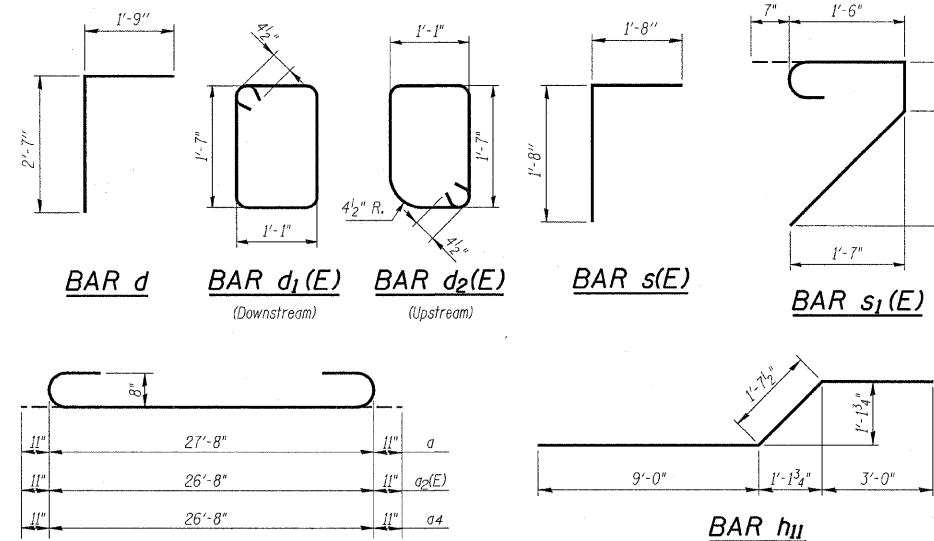

BAR d

BAR d₁(E)

BAR d₂(E)

BAR s(E)

BAR s₁(E)

BARS a, a₂(E) & a₄

BARS h₄, h₅ & h₁₂

BILL OF MATERIAL

Bar	No.	Size	Length	Shape
a	20	#8	29'-6"	U
a ₁	38	#6	27'-8"	U
a ₂ (E)	34	#8	28'-6"	U
a ₃ (E)	66	#6	26'-8"	U
a ₄	16	#8	28'-6"	U
a ₅	32	#6	26'-8"	U
d	50	#4	4'-4"	L
d ₁ (E)	25	#4	5'-10"	L
d ₂ (E)	25	#4	5'-10"	L
h(E)	52	#4	17'-2"	U
h ₁	84	#6	17'-2"	U
h ₂	52	#7	17'-2"	U
h ₃	48	#5	17'-2"	U
h ₄	140	#9	8'-0"	U
h ₅	84	#9	22'-8"	U
h ₆ (E)	12	#6	27'-8"	U
h ₇ (E)	8	#7	15'-10"	U
h ₈ (E)	88	#6	17'-2"	U
h ₉	6	#6	27'-8"	U
h ₁₀	44	#7	10'-1"	U
h ₁₁	44	#7	13'-8"	U
h ₁₂	24	#9	21'-3"	U
s(E)	64	#5	3'-4"	L
s ₁ (E)	64	#5	4'-10"	L
v	212	#5	3'-5"	U
v ₁	212	#5	12'-3"	U
v ₂	16	#5	11'-2"	U
v ₃	32	#4	16'-6"	U
v ₄	16	#5	10'-11"	U
Concrete Box Culverts		Cu. Yd.	208.4	
Reinforcement Bars		Pound	29240	
Reinforcement Bars, Epoxy Coated		Pound	9590	

NOTES:

1. A distance of half the length of the wingwall but not less than six feet of the barrel shall be poured monolithically with the wingwalls.
2. Reinforcement bars designated (E) shall be epoxy coated.

DESIGNED	BWB
CHECKED	MAA
DRAWN	PJP
CHECKED	BSC

PLANS PREPARED BY:

WOOLPERT LLP
343 Fountains Parkway, Suite A
Fairview Heights, IL
62208-2044
618.632.7004
FAX: 618.632.0100

STATE OF ILLINOIS
DEPARTMENT OF TRANSPORTATION
IL ROUTE 10 OVER
FRIENDS CREEK DITCH
FAP 721 - SECTION 114BR-2
DEWITT COUNTY
STATION 673+93.40
STRUCTURE No. 020-2010
CULVERT DETAILS