

CELLULAR NEOPRENE GASKET

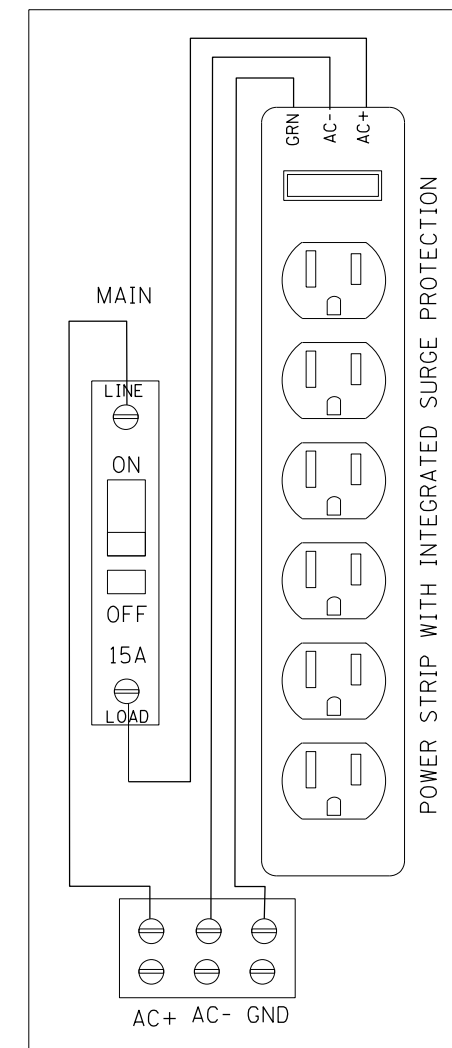

ITS EQUIPMENT CABINET POWER PANEL DETAIL
(TERMINAL STRIP TO BE EQUIPPED WITH PLEXI-GLASS SAFETY SHIELD)

THE CONTRACTOR SHALL FURNISH AND INSTALL ALL BRACKETING AND HARDWARE REQUIRED FOR CABINET INSTALLATION ON THE EXISTING POLE.

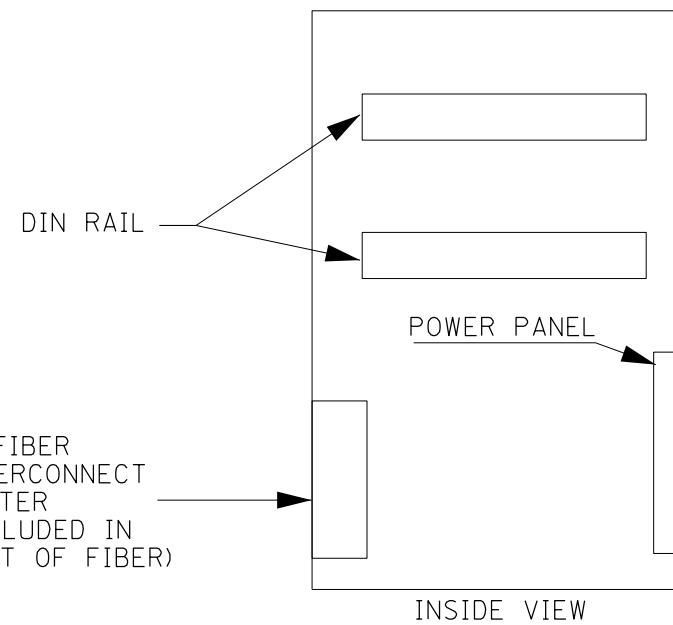

NOTES

1. THE ITS EQUIPMENT CABINET SHALL BE A NEMA TYPE 3R CABINET WITH MINIMUM OUTSIDE DIMENSIONS OF 20" (H) X 14" (W) X 10" (D) (NOMINAL). THE CABINET SHALL BE CONSTRUCTED FROM .125" THICK ALUMINUM AND HAVE A NATURAL FINISH.
2. THE CABINET SHALL BE EQUIPPED WITH A #2 CORBIN SLAM LOCK, AND ALL STAINLESS STEEL HARDWARE.

FILE NAME =	USER NAME = steffenmk	DESIGNED -	REVISED -	STATE OF ILLINOIS DEPARTMENT OF TRANSPORTATION	CLOSED CIRCUIT CABINET DETAIL		F.A.I. RTE.	SECTION	COUNTY	TOTAL SHEETS	SHEET NO.
ct:\pw\work\p\idot\steffenmk\d0360593\074643-sht-dms\installationplan.dgn	DRAWN -	REVISED -	VAR				D7 ITS 2014	•	72	27	
PLOT SCALE = 5000.0000 ' / in.	CHECKED -	REVISED -	* EFFINGHAM, CUMBERLAND		CONTRACT NO. 74643						
PLOT DATE = 6/26/2014	DATE -	REVISED -	CLARK & LAWRENCE		ILLINOIS						