

TYPICAL TANGENT RAMP SECTION
IL 4, IL 143

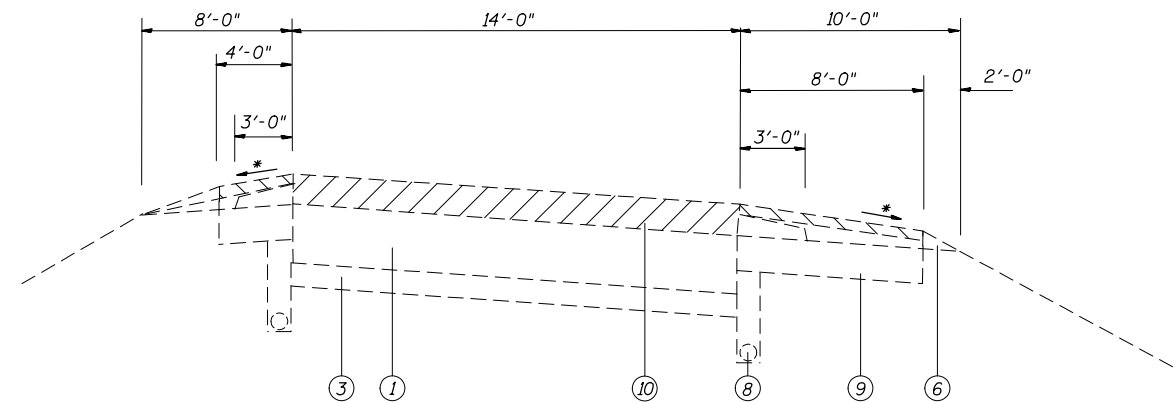

TYPICAL SUPERELEVATED RAMP SECTION
IL 4, IL 143

* MATCH EXISTING SLOPES

LEGEND

- ① EXISTING P.C.C PAVEMENT
- ② EXISTING CONTINUOUSLY REINFORCED P.C.C. PAVEMENT, 8"
- ③ EXISTING STABILIZED SUB-BASE, 4"
- ④ EXISTING HMA RESURFACING, 5"
- ⑤ EXISTING HMA SHOULDERS
- ⑥ EXISTING AGGREGATE SHOULDER, TYPE B
- ⑦ EXISTING AGGREGATE SHOULDER 13", TYPE B
- ⑧ EXISTING PIPE UNDERDRAINS
- ⑨ EXISTING STABILIZED SHOULDER
- ⑩ EXISTING BITUMINOUS RESURFACING, 3 1/4"
- ⑪ PROPOSED POLY-HMA SURFACE COURSE SMA, N80, 5" (TWO - 2 1/2" LIFTS)
- ⑫ PROPOSED HMA SHOULDERS (2 1/2")
- ⑬ PROPOSED PIPE UNDERDRAINS
- ⑭ PROPOSED POLY-BITUMINOUS PRIME COAT
- ⑮ PROPOSED AGGREGATE WEDGE SHOULDER, TYPE B (AS NEEDED)
- ⑯ PROPOSED CONTINUOUSLY REINFORCED PORTLAND CEMENT CONCRETE PAVEMENT, 8"
- ⑰ PROPOSED HMA STABILIZED SUBBASE 4"
- ⑱ PROPOSED SUBBASE GRANULAR MATERIAL, TYPE A, 12"
- ⑲ PROPOSED HMA BASE COURSE, (SEE DETAIL)
- ⑲ PROPOSED HMA BASE COURSE, (SEE DETAIL)
- ⑲ PROPOSED POLY-HMA SURFACE COURSE SMA, N80, 4" (TWO - 2" LIFTS)
- ⑲ PROPOSED POLY-HMA SHOULDERS, 2 1/4"

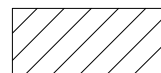

PROPOSED HMA SURFACE REMOVAL, 3/4"



PROPOSED HMA SURFACE REMOVAL, 1/2"

FILE NAME =	USER NAME = \$USER*	DESIGNED -	REVISED -
FILEL		DRAWN -	REVISED -
	PLOT SCALE = \$SCALE*	CHECKED -	REVISED -
	PLOT DATE = \$DATE*	DATE -	REVISED -

STATE OF ILLINOIS
DEPARTMENT OF TRANSPORTATION

EXISTING TYPICALS

SCALE: NTS SHEET NO. OF SHEETS STA. TO STA.

F.A.I. RTE.	SECTION	COUNTY	TOTAL SHEETS	SHEET NO.
70	60-(11,12)RS-3	MADISON	242	15
CONTRACT NO. 76F13				
FED. ROAD DIST. NO. ILLINOIS FED. AID PROJECT				