

EMERGENCY MEDIAN CROSSOVERS

NOTES:
 TWO DELINEATORS SHALL BE PLACED IN ADVANCE OF THE MEDIAN CROSSOVERS. ONE SHALL BE AT THE CROSSOVER, THE OTHER 800 FT IN ADVANCE OF THE FIRST. THE DELINEATOR AT THE CROSSOVER SHALL HAVE TWO AMBER REFLECTORS, AND THE DELINEATOR 800 FT IN ADVANCE SHALL HAVE THREE AMBER REFLECTORS
 OMIT RUMBLE STRIPS IN SHADED [Hatched Box] AREAS OF SHOULDER

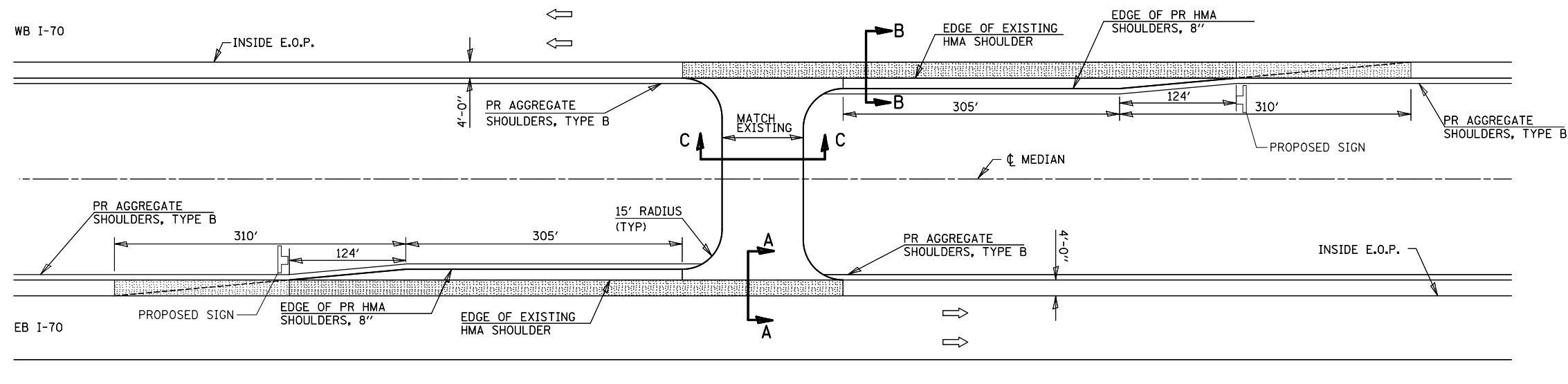

PLAN VIEW

STA. 1139+72
 STA. 1271+25
 STA. 1517+58

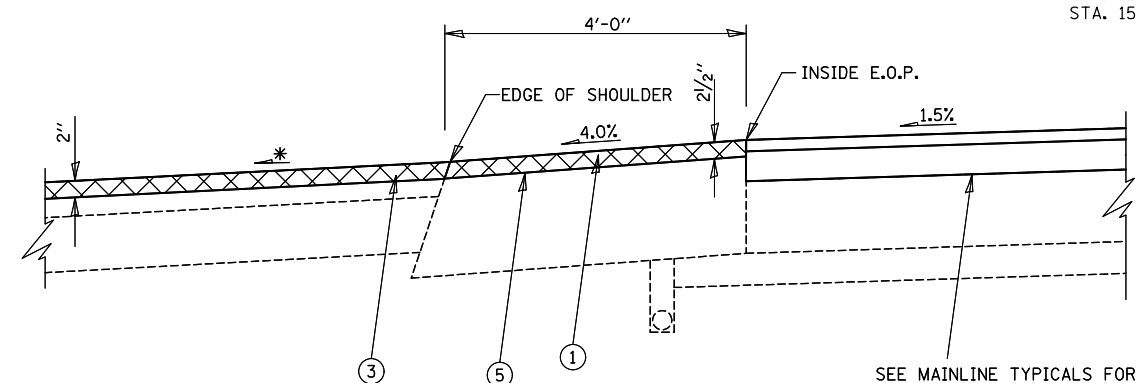

SECTION A - A

* - MAINTAIN SLOPES AWAY FROM MAINLINE PAVEMENT TO ENSURE PROPER DRAINAGE INTO MEDIAN DITCHES.

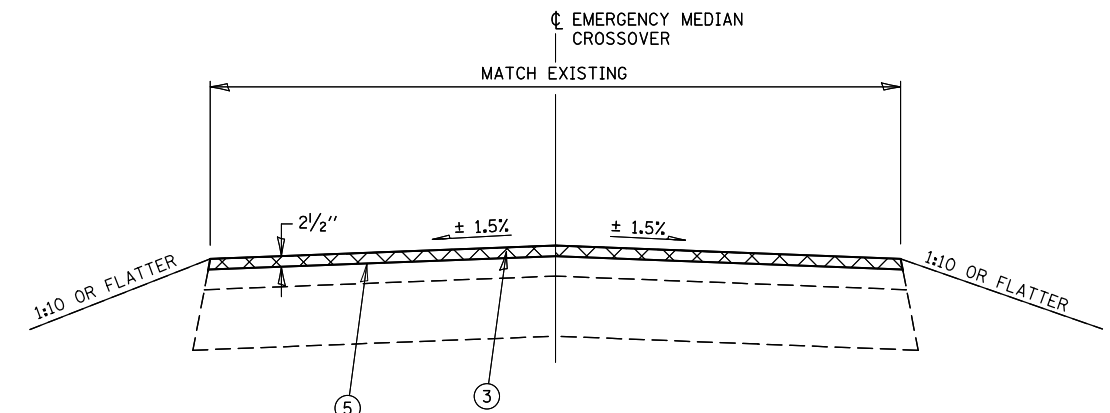

SECTION C - C

[Hatched Box] HMA SURFACE REMOVAL 2 1/2"

LEGEND	
①	PROPOSED HOT-MIX ASPHALT SHOULDERS, 2 1/2"
②	PROPOSED HOT-MIX ASPHALT SHOULDERS, 8"
③	PROPOSED POLYMERIZED HOT-MIX ASPHALT SURFACE COURSE, SMA, N80, 2 1/2"
④	PROPOSED AGGREGATE WEDGE SHOULDERS, TYPE B
⑤	PROPOSED POLY BITUMINOUS MATERIAL (PRIME COAT)

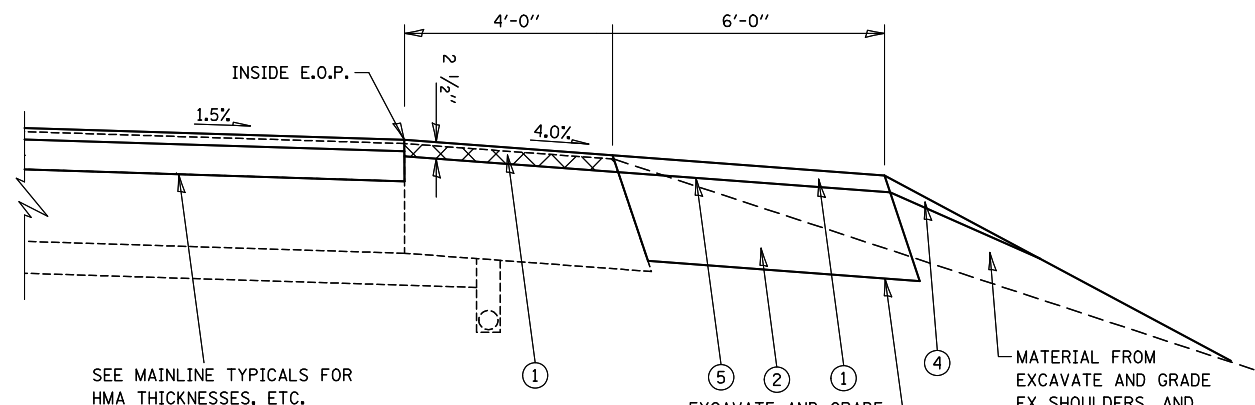

SECTION B - B

* - MAINTAIN SLOPES AWAY FROM MAINLINE PAVEMENT TO ENSURE PROPER DRAINAGE INTO MEDIAN DITCHES.

FILE NAME = #FILE#	USER NAME = #USER#	DESIGNED -	REVISED -	STATE OF ILLINOIS DEPARTMENT OF TRANSPORTATION	EMERGENCY MEDIAN CROSS OVER DETAIL			F.A.I. RTE.	SECTION	COUNTY	TOTAL SHEETS	SHEET NO.
		DRAWN -	REVISED -						60-(11,12)RS-3		242	174
		CHECKED -	REVISED -					CONTRACT NO. 76F13				
		DATE -	REVISED -					ILLINOIS FED. AID PROJECT				
				SCALE:		SHEET NO. OF SHEETS		STA. TO STA.				