

PROPOSED TYPICAL SECTION
STA 1+36 TO 3+86

NOTE: STA 2+65 TO STA 3+86 RT - GUTTER IS OVERLAID

LEGEND

- ① EXISTING PCC PAVEMENT, 9"
- ② EXISTING PCC PAVEMENT, 9"-6"-9"
- ③ EXISTING PCC BASE COURSE, 7"
- ④ EXISTING PCC BASE COURSE WIDENING, 8"
- ⑤ EXISTING HMA BASE COURSE, 11"
- ⑥ EXISTING HMA OVERLAY
- ⑦ EXISTING HMA OVERLAY, 1-1/2"
- ⑧ EXISTING HMA OVERLAY, 2-1/2"
- ⑨ EXISTING HMA OVERLAY, 7-1/4"
- ⑩ EXISTING HMA SHOULDERS, 8"
- ⑪ EXISTING AGGREGATE SHOULDERS, 6"
- ⑫ EXISTING CURB AND GUTTER
- ⑬ EXISTING LIME MODIFIED SOIL, 12"
- ⑭ EXISTING PAVEMENT MARKING LINE
- ⑮ PROPOSED HMA SURFACE REMOVAL, 2-1/2"
- ⑯ PROPOSED LEVELING BINDER, IL 9.5FG, N70, 1"
- ⑰ PROPOSED HMA POLY SURFACE COURSE, MIX D, N70, 1-1/2"
- ⑱ PROPOSED BITUMINOUS MATERIALS (PRIME COAT)
- ⑲ PROPOSED HMA SHOULDERS, 2-1/2"
- ⑳ PROPOSED PAVEMENT MARKING LINE
- ㉑ PROPOSED STRIP REFLECTIVE CRACK CONTROL TREATMENT

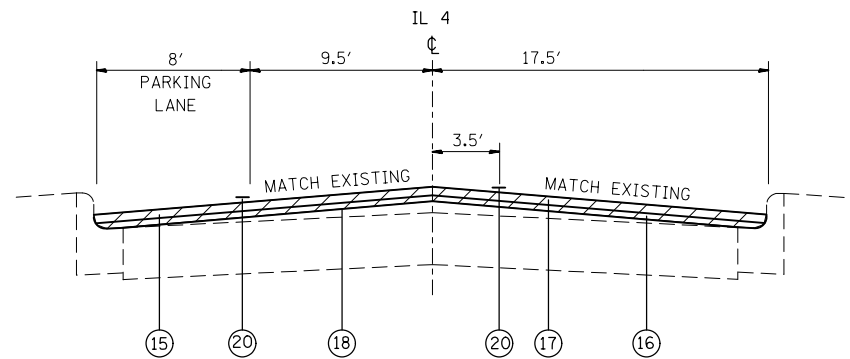

PROPOSED TYPICAL SECTION
STA 3+86 TO 6+68

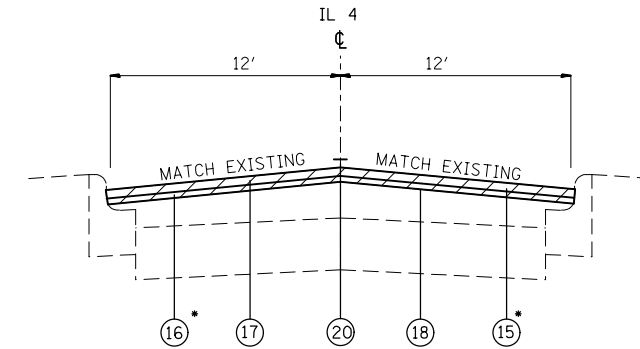

PROPOSED TYPICAL SECTION
STA 6+68 TO STA 34+74

NOTE:

- STA. 7+43 TO STA. 8+93; TAPER MILLING FROM 2-1/2" TO 0"
- STA. 8+93 TO STA. 9+43; TAPER BINDER (16) FROM 1" TO 1-1/2"
- STA. 9+43 TO STA. 10+43; BINDER (16) = 1-1/2"
- STA. 10+43 TO STA. 10+93; TAPER BINDER (16) FROM 1-1/2" TO 1"
- STA. 10+93 TO STA. 12+23; TAPER MILLING (16) FROM 0" TO 2-1/2"
- STA. 8+93 TO STA. 10+93; NO MILLING

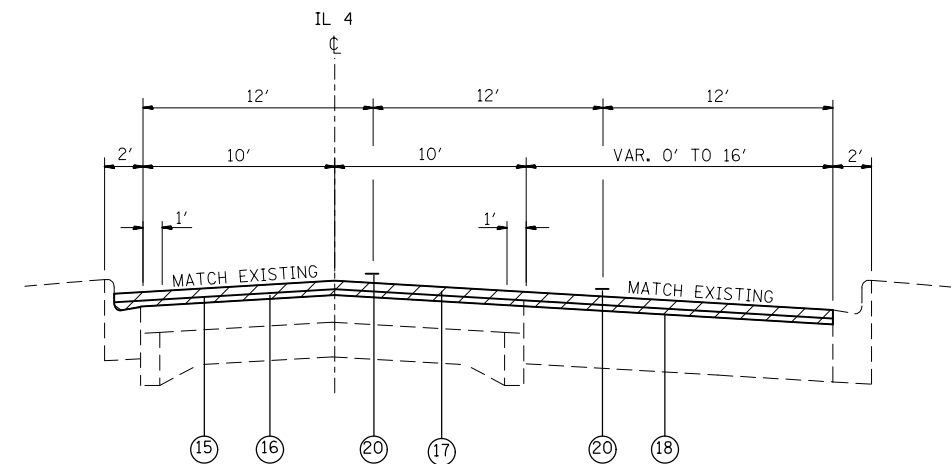

PROPOSED TYPICAL SECTION
STA 34+74 TO 50+70

| | | | |
|---|------------------------|------------|-----------|
| FILE NAME = | USER NAME = burnsideem | DESIGNED - | REVISED - |
| et:\pw\work\p\dot\burnsideem\d0378703\0876g97-sh-t-plan.dgn | | DRAWN - | REVISED - |
| PLOT SCALE = 100.0000' / 1in. | | CHECKED - | REVISED - |
| PLOT DATE = 7/11/2014 | | DATE - | REVISED - |

STATE OF ILLINOIS
DEPARTMENT OF TRANSPORTATION

TYPICAL SECTIONS

SCALE: SHEET NO. OF SHEETS STA. TO STA.

| | | | | |
|---|----------|----------|--------------------|-----------|
| F.A.P. RTE. | SECTION | COUNTY | TOTAL SHEETS | SHEET NO. |
| IL 4 | 21-IRS-4 | RANDOLPH | 24 | 7 |
| FED. ROAD DIST. NO. ILLINOIS FED. AID PROJECT | | | CONTRACT NO. 76G97 | |