

NOTES:

1. THE COST OF THE THRUST BLOCKS NECESSARY FOR PIPE PROTECTION AT BENDS SHALL NOT BE PAID FOR SEPARATELY BUT SHALL BE INCLUDED IN THE COST OF THE "STORM SEWER" OF THE TYPE AND SIZE AS SHOWN ON PROPOSED DRAINAGE PLANS.
2. PRECAST REINFORCED CONCRETE FLARED END SECTION (IDOT STANDARD 542301) ON IDOT R.O.W. OR SLOPED HEADWALLS TYPE III (ISHTA STANDARD B10-00) AND AS INDICATED ON DRAINAGE SCHEDULES.

SECTION SLOPED PIPE DRAIN
N.T.S.

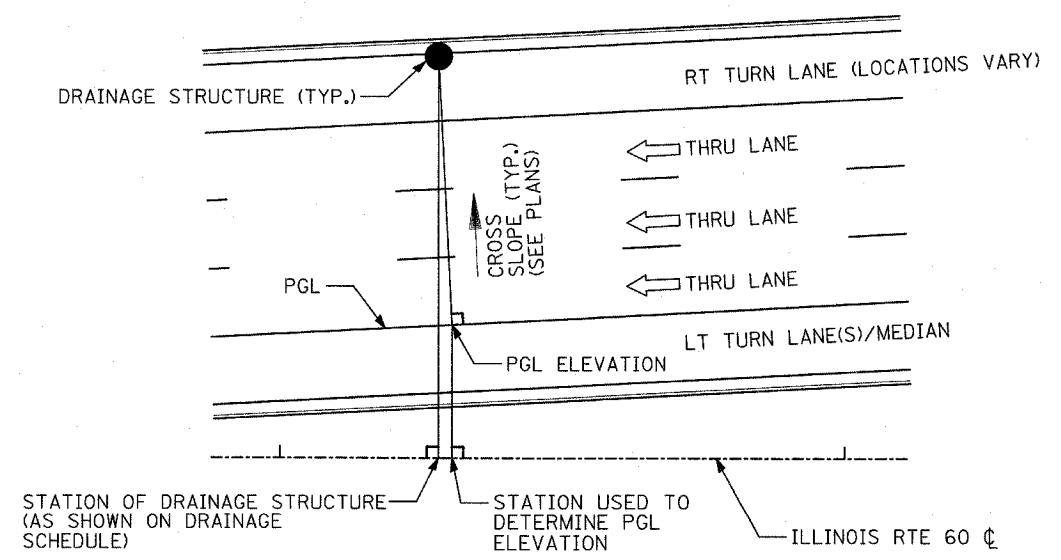

CALCULATION OF STRUCTURE RIM ELEVATION
TO BE USED WHERE PGL IS NOT PARALLEL TO CENTERLINE

NOTE: SEE PLANS FOR LANE CONFIGURATIONS

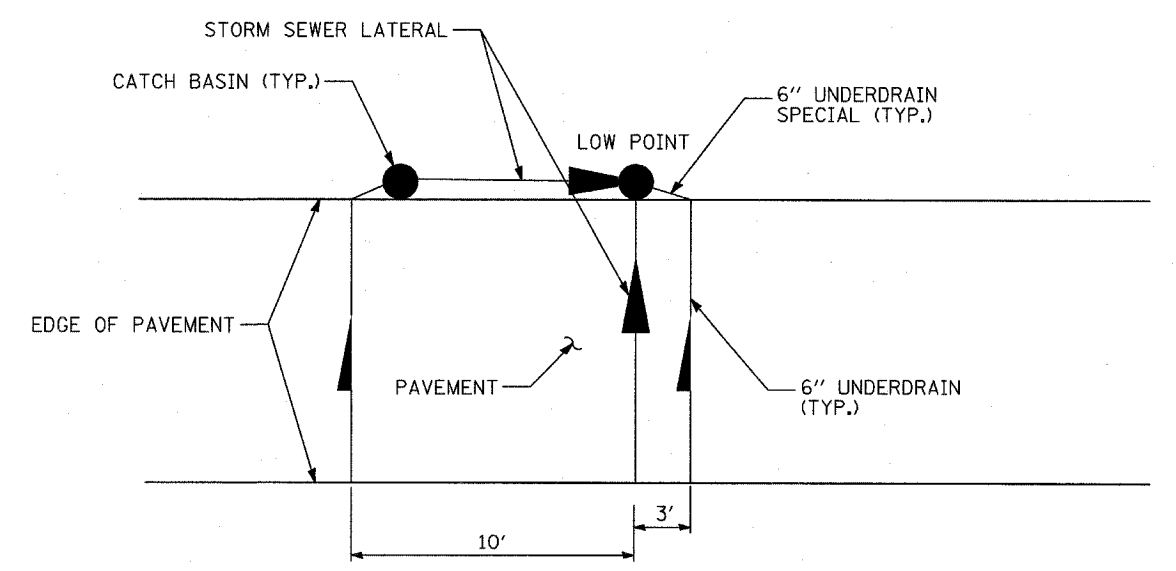

PIPE UNDERDRAIN 6\", AT ROADWAY SAGS

REVISIONS	
NAME	DATE

ILLINOIS DEPARTMENT OF TRANSPORTATION
ILLINOIS RTE 60 OVER I-94
DRAINAGE DETAILS

SCALE: NONE
DATE: MAY 8, 2007
DRAWN BY: NSB
CHECKED BY: DA

02-19-04 PM 06/13/2007