

FUSE PLATE DATA		
N = Bolt Diameter	G	H
1/2"	2"	1 1/8"
5/8"	2 1/4"	1 1/4"
3/4"	2 1/2"	1 3/8"
7/8"	2 3/4"	1 1/2"
1"	3"	1 5/8"
1 1/8"	3 1/4"	1 3/4"

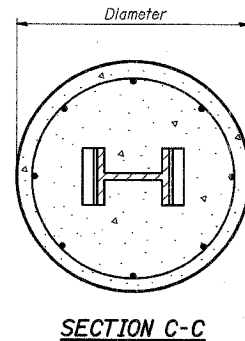
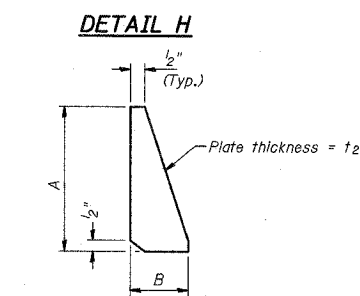
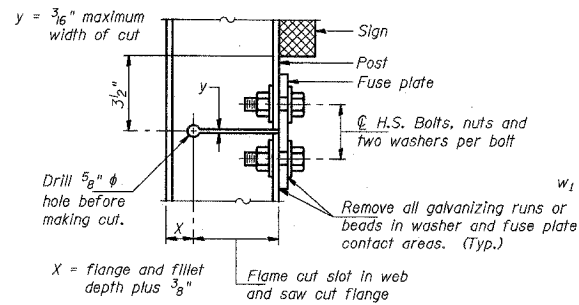
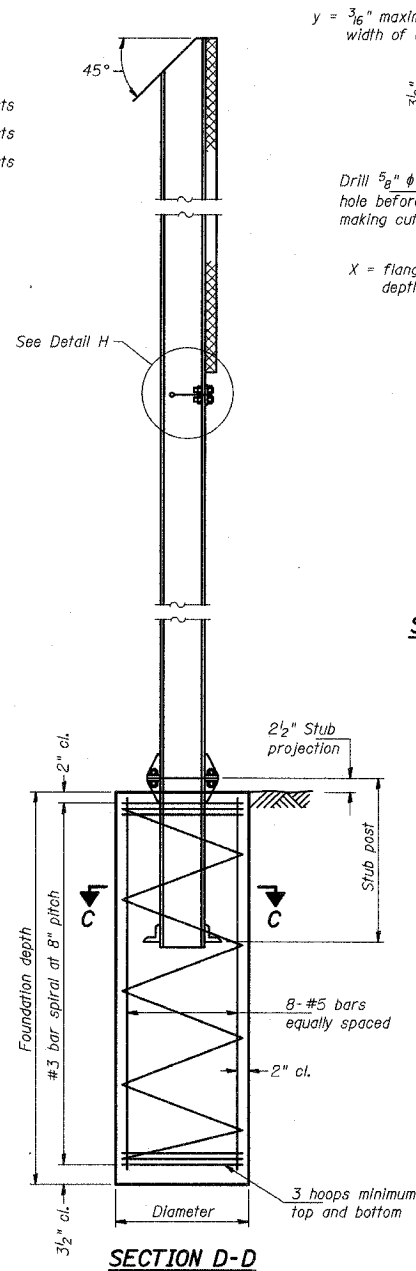

**GENERAL NOTES**

Posts shall be plumbed by using shims with post-to-stub post connection bolts snug tight only. Final tightening of all High Strength Bolts shall be in accordance with Article 727.05, and threads at the junction of the bolt and nut shall be burred or center punched to prevent the nut from loosening.

LOADING: 80 m.p.h. wind with 30% gust factor, normal to sign.

DESIGN STRESSES:  
 Structural steel - 20,000 p.s.i.  
 Reinforcing steel - 20,000 p.s.i.  
 Concrete - 1,400 p.s.i.  
 Footing soil pressure - 2,000 p.s.f.

After fabrication, the post, fuse plate and upper 6" (Minimum) of the stub post shall be hot-dip galvanized in accordance with AASHTO M111. All bolts, nuts and washers shall be hot-dip galvanized in accordance with AASHTO M232.

Work this sheet with Base Sheet BAW-A-2.

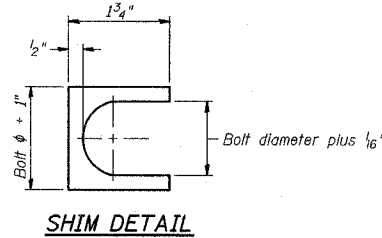
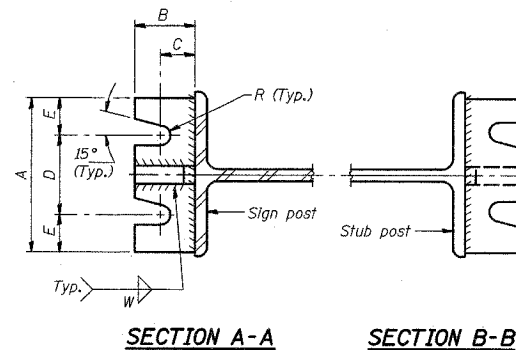
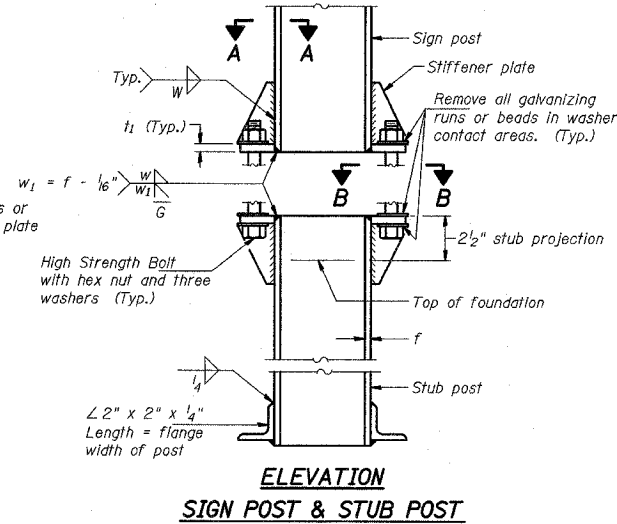

Furnish two 0.01" thick and two 0.03" thick stainless steel or brass (ASTM B36) shims per post.

BAW-A-1 7/1/2006

TYLIN INTERNATIONAL

NUMBER	REVISION	DATE

REVISIONS		ILLINOIS DEPARTMENT OF TRANSPORTATION ILLINOIS RTE 60 OVER I-94 BREAK-AWAY WIDE FLANGE STEEL SIGN POST DETAILS
NAME	DATE	

SCALE: AS NOTED      DRAWN BY: AMB  
 DATE: MAY 8, 2007      CHECKED BY: DMJ

P:\602-6811-60N\road\60bw\_sft01.dgn 5/8/2007 5:25:46 PM