

TYPICAL EXPRESSWAY CROSS-SECTION NO. 1

LEGEND

- ① AREA OF EXPRESSWAY SHOULDER CLEANING AND RUBBISH REMOVAL
- ② TRAVELED ROADWAY
- ③ STABILIZED SHOULDER OR MEDIAN
- ④ CONCRETE BARRIER
- ⑤ NON STABILIZED SURFACE

NOTE:

A) ALL LOCATIONS OF GUARDRAIL ON LEFT SHOULDERS SHALL BE CLEANED BY HAND LABORING UNDERNEATH AND 10 FEET BEHIND STABILIZED AND NON STABILIZED AREAS. THIS WORK SHALL BE CONSIDERED AS INCLUDED IN THE CONTRACT UNIT PRICE FOR ALL FULL CLEANING CYCLES.

B) DEBRIS SHALL BE REMOVED FROM ALL STABILIZED AREAS, UNDER AND 10 FEET BEHIND ALL GUARDRAIL AND ALL AGGREGATE/ STONE SHOULDERS REGARDLESS OF WIDTH.

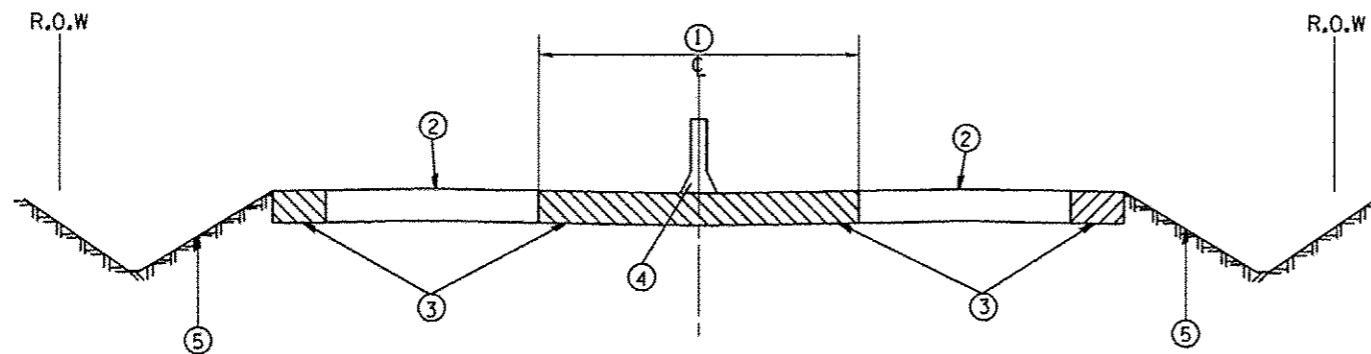

TYPICAL EXPRESSWAY CROSS-SECTION NO. 2

FILE NAME : c:\pwwork\p1\dot\pyrzanowski\030327	USER NAME : pyrzanowski	DESIGNED -	REVISED -	<b>STATE OF ILLINOIS DEPARTMENT OF TRANSPORTATION</b>	<b>TYPICAL I-55 EXPRESSWAY CROSS SECTIONS</b>			F.A.I. RTE: 55	SECTION 2012-0461	COUNTY COOK & DUPAGE	TOTAL SHEETS 6	SHEET NO. 4
	PLLOT SCALE : 100.0000' / 1" =	DRAWN -	REVISED -		SCALE:	SHEET NO.	OF SHEETS	STA.	TO STA.	<b>CONTRACT NO. 60V35</b>		
	PLLOT DATE : 6/29/2012	CHECKED -	REVISED -		ILLINOIS FED. AID PROJECT							
		DATE -	REVISED -									