

When "A" is 3'-6" or less, the temporary concrete barrier shall be anchored to the new slab according to Detail I or Detail II. No anchorage is required when "A" is greater than 3'-6".

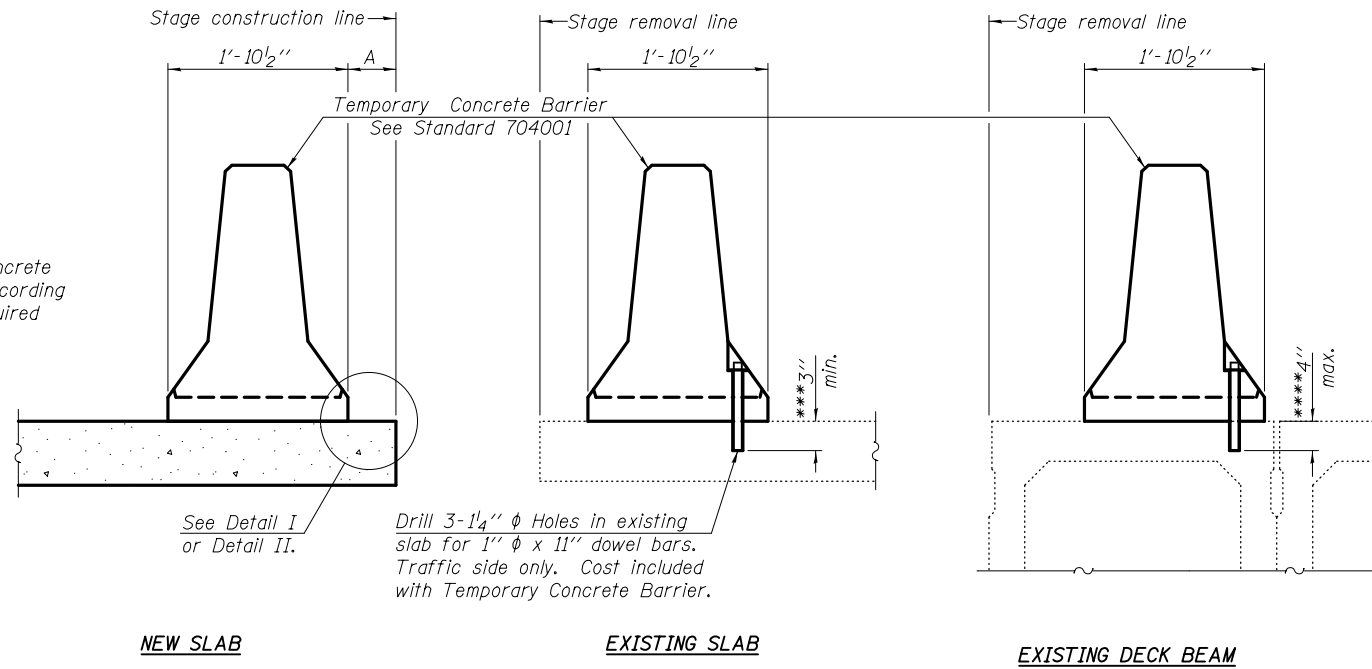

**SECTIONS THRU SLAB OR DECK BEAM**

**NOTES**

Detail I - With Bar Splicer or Couplers:  
Connect one (1) 1" x 7" x "W" steel PL to the top layer of couplers with 2-5/8" φ bolts screwed to coupler at approximate C of each barrier panel.

Detail II - With Extended Reinforcement Bars:  
Connect one (1) 1" x 7" x "W" steel PL to the concrete slab or concrete wearing surface with 2-5/8" φ Expansion Anchors or cast in place inserts spaced between the top layer of reinforcement at approximate C of each barrier panel.

Cost of anchorage is included with Temporary Concrete Barrier. The 1" x 7" x "W" plate shall not be removed until stage II construction forms and all reinforcement bars are in place and the concrete is ready to be placed.

\*\*\* Dimension shown is minimum required embedment into concrete. If hot-mix asphalt wearing surface is present, minimum embedment shall be in addition to wearing surface depth.

\*\*\*\* If existing deck beam is to remain in place after stage construction, embedment shall only be into wearing surface and not into existing deck beam concrete.

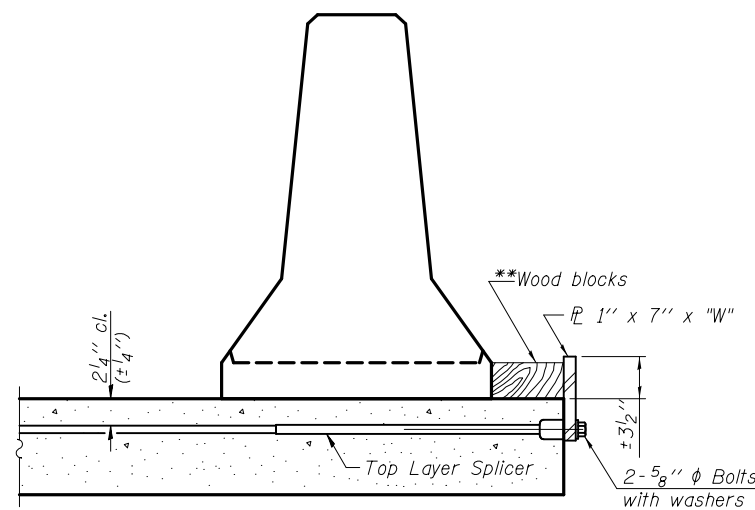

**DETAIL I**

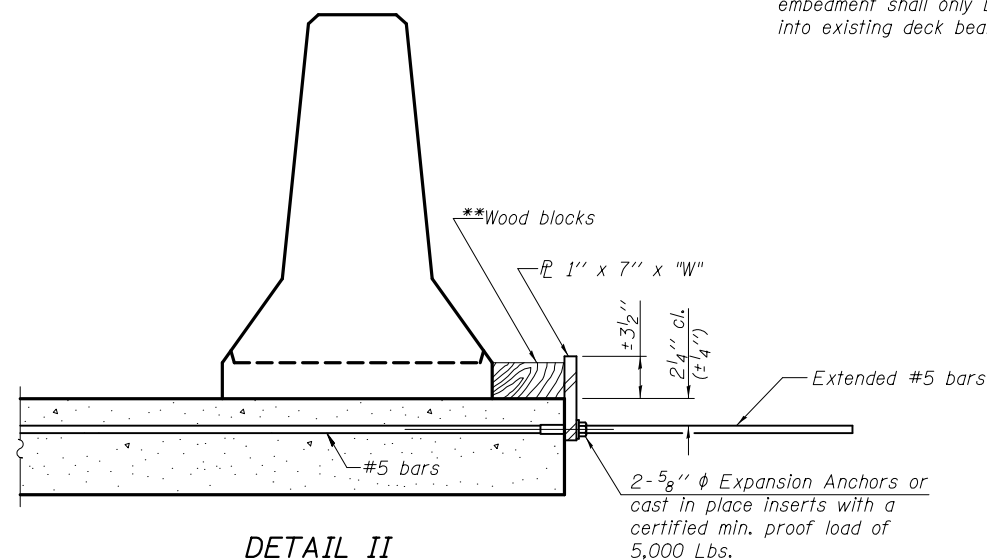

**DETAIL II**

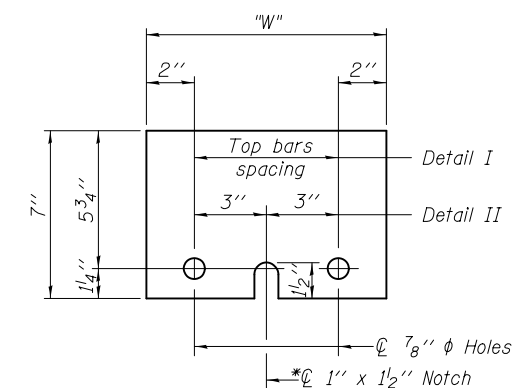

**STEEL RETAINER PL 1" x 7" x "W"**

\* Required only with Detail II

\*\* Wood blocks may be omitted when required to provide minimum stage traffic lane width. When the wood blocks are omitted, the concrete barrier shall be in direct contact with the steel retainer plate.

"W" = Top bars spacing + 4"

R-27 7-1-10

DESIGNED - AYV	EXAMINED	DATE -
CHECKED - PSK	ENGINEER OF STRUCTURAL SERVICES	
DRAWN - AYV	PASSED	
CHECKED - PSK	ENGINEER OF BRIDGES AND STRUCTURES	

**STATE OF ILLINOIS  
DEPARTMENT OF TRANSPORTATION**

**TEMPORARY CONCRETE BARRIER FOR STAGE CONSTRUCTION  
STRUCTURE NO. 079-0038**

SHEET NO. 7 OF 9 SHEETS

IL RTE.	SECTION	COUNTY	TOTAL SHEETS	SHEET NO.
4/150	110-BR	RANDOLPH	20	18
			CONTRACT NO. 76F53	

ILLINOIS FED. AID PROJECT