

STATE OF ILLINOIS
DEPARTMENT OF TRANSPORTATION

ROUTE NO.	SECTION	COUNTY	TOTAL SHEETS	SHEET
F.A.I. RTE. 90/94		COOK	247	102
FED. ROAD DIST. NO. 1	ILLINOIS	FED. AID PROJECT		
• (1919.15 & 2021-922 PT.1) R-2				60A63

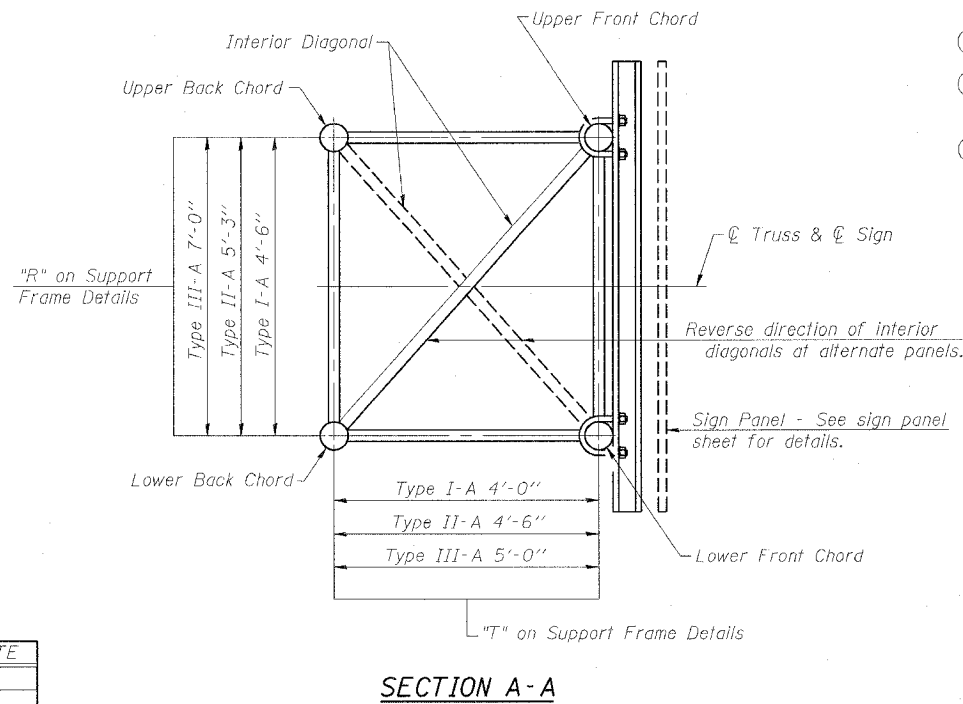
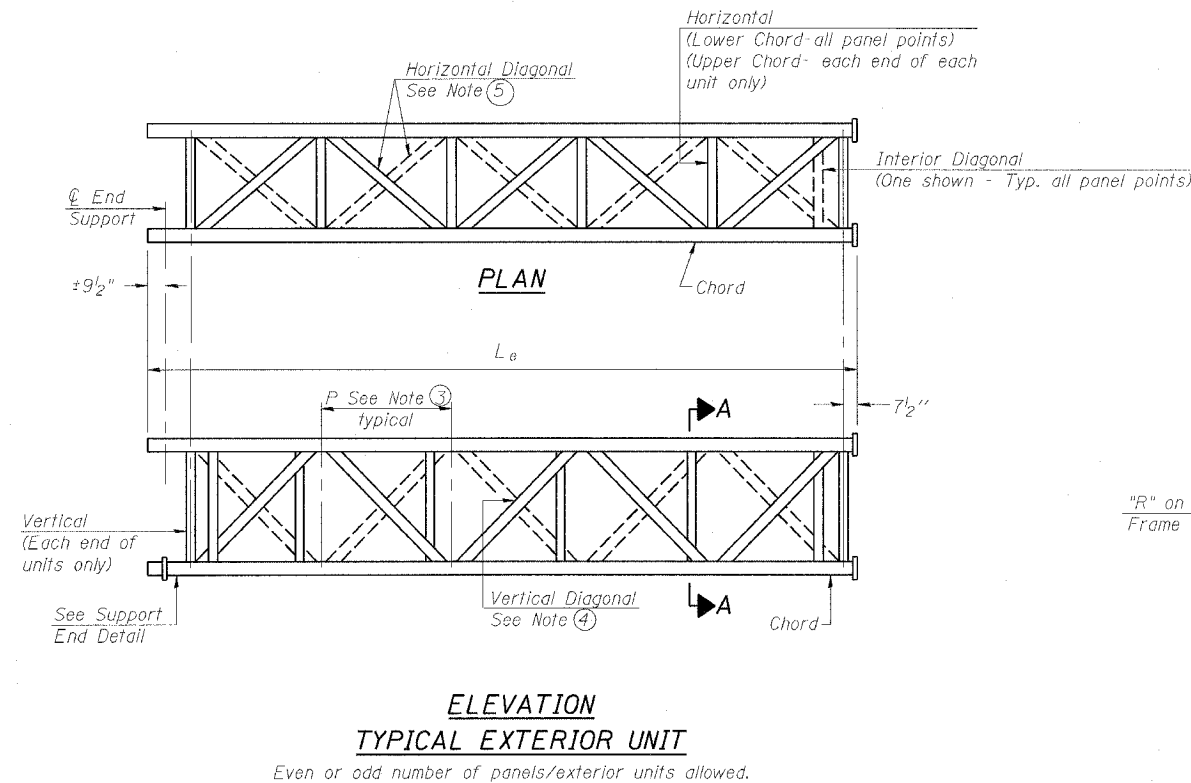
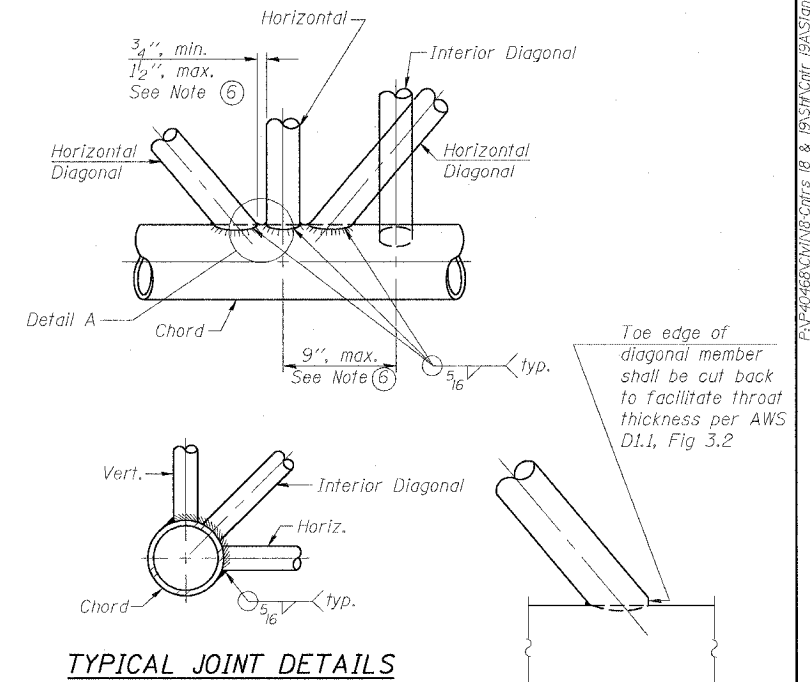
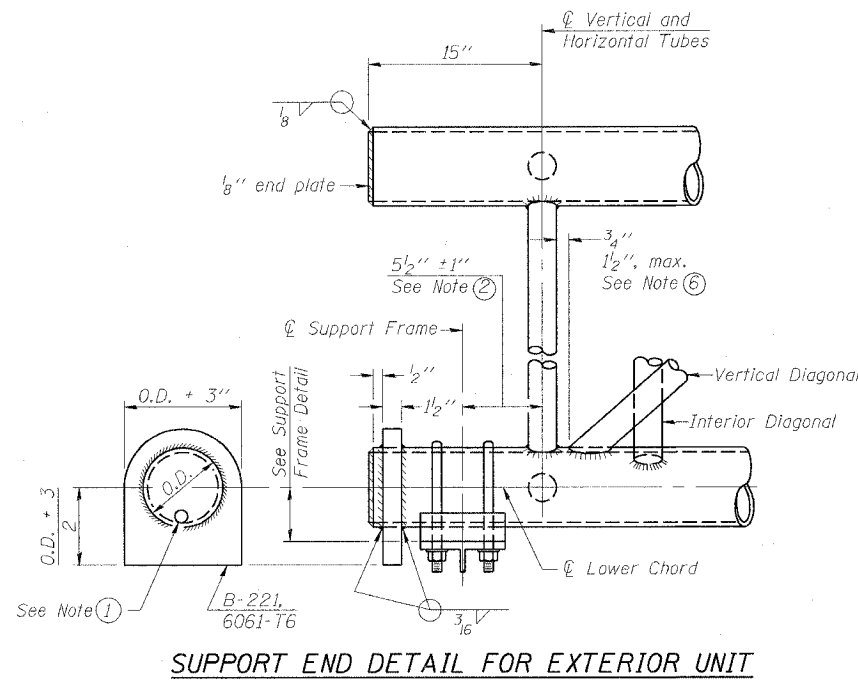
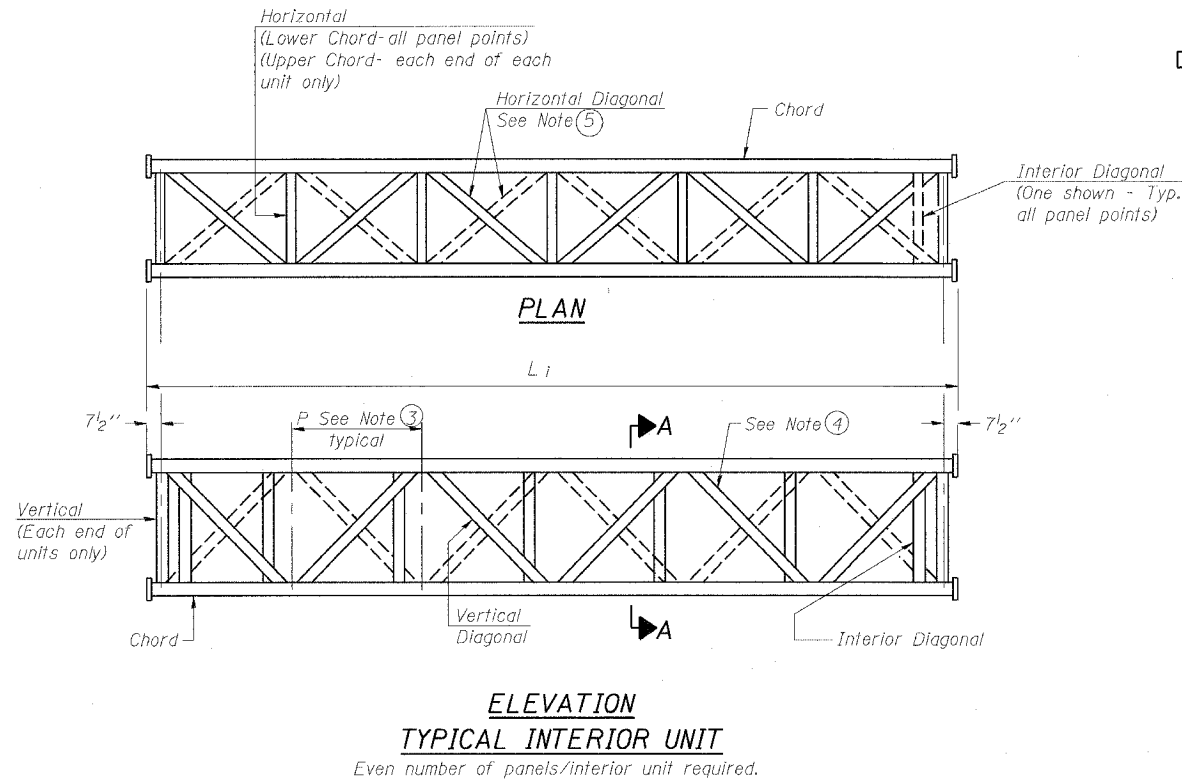

- NOTES**
- Contractor may alternatively use standard aluminum drive-fit cap to close end. 1/2" Ø drain hole in end plate/drive-fit cap. (Typ. at ends of all chords)
 - 5 1/2" end dimension may vary by ± 1" to provide uniform panel spacing (P).
 - Panel spacing (P) shall be uniform for entire truss and between 4'-0" and 5'-0" for Type I-A or 4'-0" and 5'-6" for Types II-A and III-A.
 - Vertical Diagonals in front and back face shall alternate.
 - Hidden lines show wind bracing alternates direction between planes of top and bottom chords.
 - All diagonals shall be detailed for minimum offset from the panel point based on the following: Offset shall be such as to provide a 3/4" minimum to 1/2" maximum clearance between any diagonal and any horizontal or vertical member, and to provide clearance for U-bolt connections of signs or walkway brackets.

DESIGNED	JSS
CHECKED	MJP
DRAWN	JSS
CHECKED	MJP

EXAMINED	20
PASSED	ENGINEER OF STRUCTURAL SERVICES
	ENGINEER OF BRIDGES AND STRUCTURES

NUMBER	REVISION	DATE

OS-A-2 1-7-05

OSS-4

**OVERHEAD SIGN STRUCTURES
ALUMINUM TRUSS DETAILS
FOR TRUSS TYPES I-A, II-A and III-A**

F.A.I. 90/94 (DAN RYAN EXPRESSWAY)
63RD STREET TO GARFIELD BLVD (SB LOCAL LANES)
PROPOSED IMPROVEMENT

6/12/2006 11:23:02 AM