

STATE OF ILLINOIS
DEPARTMENT OF TRANSPORTATION

F.A.I. RTE. 90/94	SECTION •	COUNTY COOK	TOTAL SHEETS 247	SHEET NO. 178
STA. 60A63		TO STA.		
FED. ROAD DIST. NO. 1 ILLINOIS FED. AID PROJECT				
• (1919.15, 2021-922 PT1 & PT2) R-2				

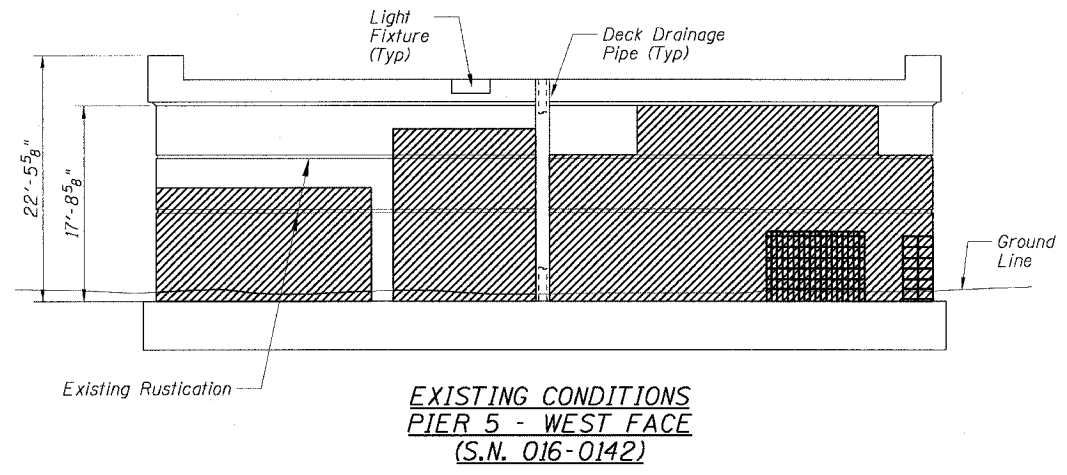
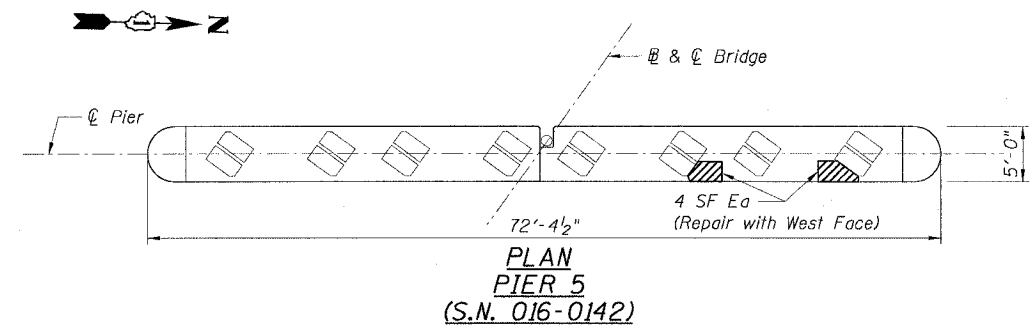

LEGEND:
(For Existing Conditions
Pier 5 - West Face)

- Spalled or Delaminated Concrete
- Spalled Concrete with Exposed Rebar

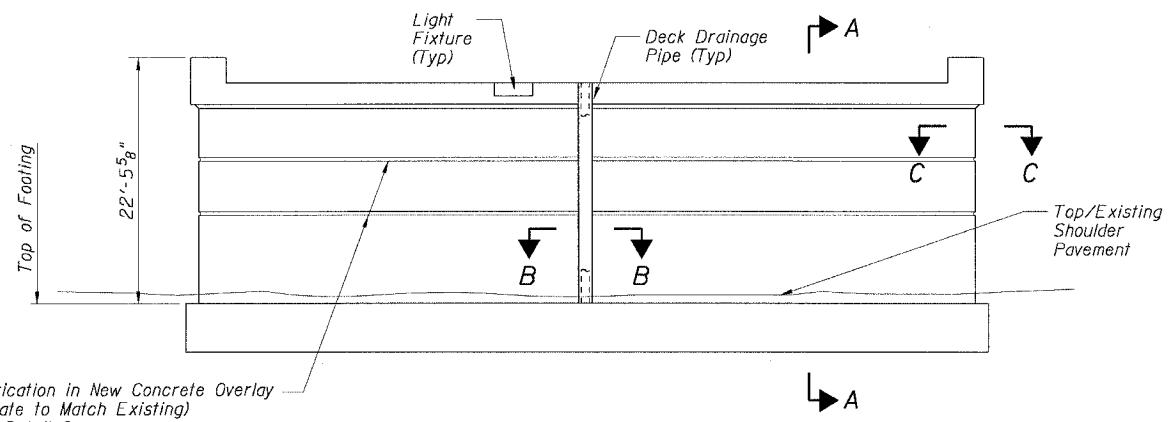

BILL OF MATERIAL		
Item	Unit	Quantity
Structural Repair of Concrete (Special)	Sq Ft	1,196
Structural Repair of Concrete (Depth Equal to or Less Than 5")	Sq Ft	8
Protective Coat	Sq Yd	134

CTE | AECOM

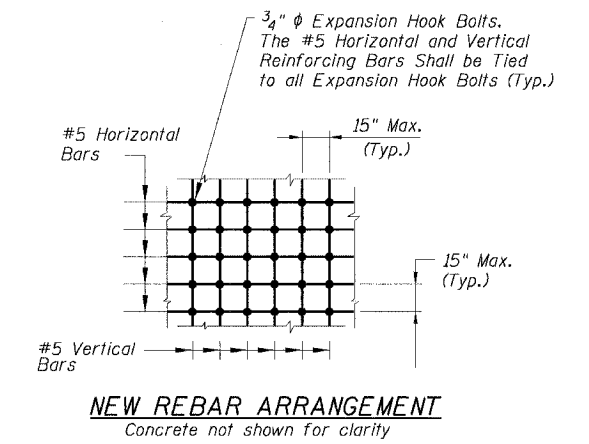
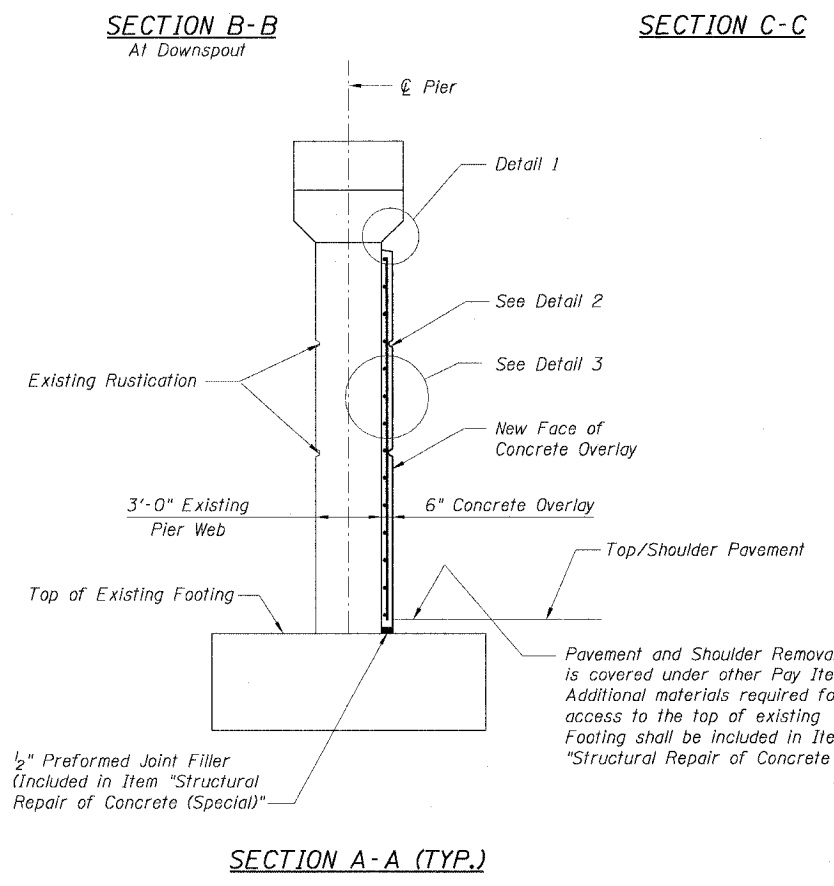
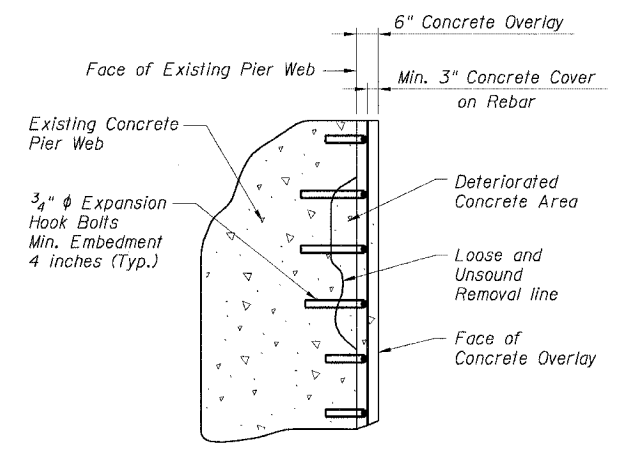
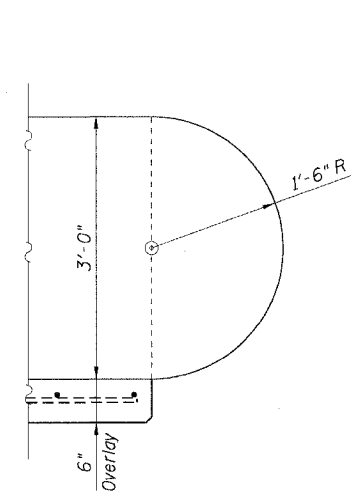
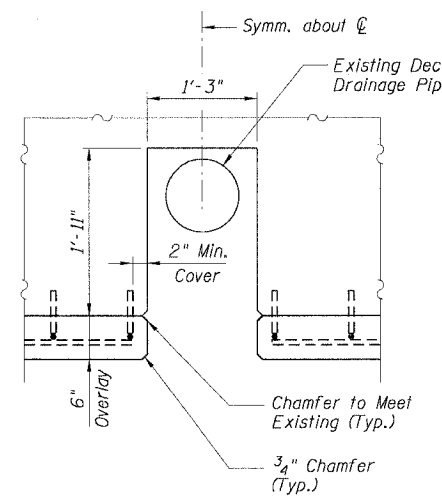
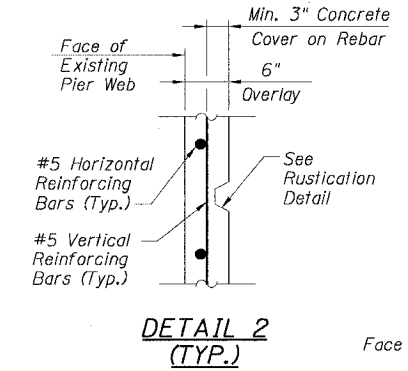
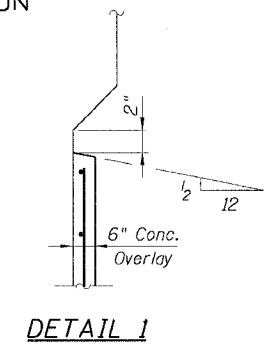
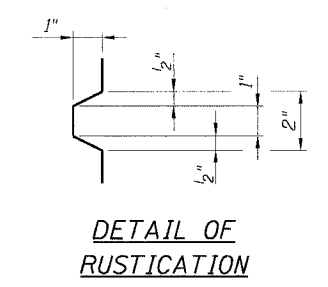

NOTE:
The Furnishing and Placing of the Expansion Hook Bolts and the #5 Horizontal and Vertical Reinforcing Bars shall be Included in Item "Structural Repair of Concrete (Special)". Reinforcing Bars shall be Epoxy Coated and conform to AASHTO M31 or M322 Grade 60 (U.N.O.)

REVISIONS	
NAME	DATE

ILLINOIS DEPARTMENT OF TRANSPORTATION
F.A.I. 90/94 (DAN RYAN EXPRESSWAY)
63RD STREET TO GARFIELD BLVD (SB LOCAL LANES)
PIER 5 - PLAN AND ELEVATION
SUBSTRUCTURE AND ABUTMENT REPAIRS
CONRAIL BRIDGE (SN 016-0142)
COOK COUNTY

SCALE: None
DATE: June 9, 2006

DRAWN BY: CHD/SR
CHECKED BY: MJP

Sheet BR4 of 6

F:\P\0668\Struct\8-Corr\1889\9C\1819\A\SP\RT\18A0042A-60\603.DWG 5/27/2006 10:52:46 AM