

**EXISTING TYPICAL SECTION**

STA. 107+59.00 TO STA. 108+59.00  
 STA. 108+89.00 TO STA. 109+89.00

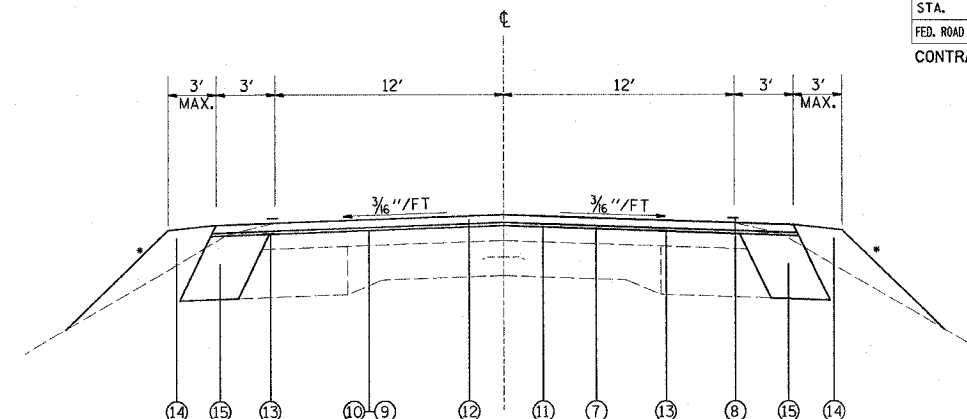

**PROPOSED TYPICAL SECTION**

STA. 107+59.00 TO STA. 108+59.00  
 STA. 108+89.00 TO STA. 109+89.00

• SEE CROSS SECTIONS FOR SIDE SLOPE

**LEGEND**

- ① EXISTING PAVEMENT 9-6-9
- ② EXISTING BITUMINOUS BINDER, 3"±
- ③ EXISTING PAVEMENT MARKING
- ④ EXISTING BITUMINOUS WIDENING, 9"
- ⑤ EXISTING BITUMINOUS SURFACE COURSE, 1 1/2 "
- ⑥ EXISTING AGGREGATE SHOULDER
- ⑦ PROPOSED BITUMINOUS SURFACE REMOVAL (VARIABLE DEPTH)
- ⑧ PROPOSED PAVEMENT MARKING
- ⑨ PROPOSED BITUMINOUS MATERIAL (PRIME COAT)
- ⑩ PROPOSED AGGREGATE (PRIME COAT)
- ⑪ PROPOSED BINDER COURSE, 3/4 "
- ⑫ PROPOSED BITUMINOUS CONCRETE SURFACE COURSE, 1 1/2 "
- ⑬ PROPOSED STRIP REFLECTIVE CRACK CONTROL
- ⑭ PROPOSED EARTH SHOULDER
- ⑮ PROPOSED BITUMINOUS CONCRETE BASE COURSE WIDENING, 12"

**MIXTURE REQUIREMENTS**

MIXTURE USE	SURFACE	LEVELING BINDER	BINDER	WIDENING COURSE
AC/PG	PG 64-22	PG 64-22	PG 64-22	PG 64-22
RAP % (MAX)	10%	10%	15%	15%
DESIGN AIR VOIDS	4% Ndes=70	4% Ndes=70	4% Ndes=70	4% Ndes=70
MIX COMPOSITION				
(GRADATION MIXTURE)		IL 9.5	IL 19.0	IL 19.0
FRICTION AGGREGATE	MIXTURE "D"	MIXTURE "C"	MIXTURE "B"	MIXTURE "B"

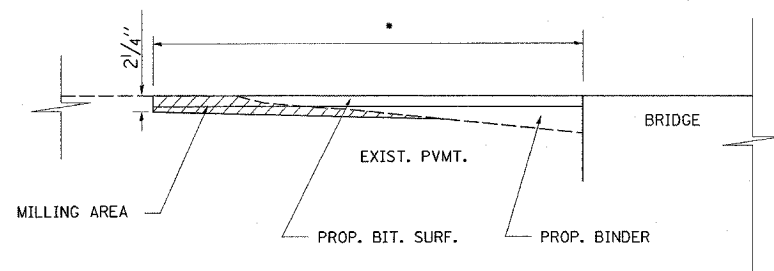

\*SEE PLAN & PROFILE FOR BEGINNING AND END STATION OF RESURFACING

**BITUMINOUS SURFACE REMOVAL DETAIL**

REVISIONS		ILLINOIS DEPARTMENT OF TRANSPORTATION TYPICAL SECTIONS/MIXTURE REQUIREMENTS & MILLING DETAIL
NAME	DATE	
		FAP ROUTE 789 SECTION 68-BR-1 MADISON COUNTY

SCALE: VERT. \_\_\_\_\_  
 HORIZ. \_\_\_\_\_  
 DATE \_\_\_\_\_ DRAWN BY \_\_\_\_\_  
 CHECKED BY \_\_\_\_\_