

F.A.U. NO.	SECTION	COUNTY	TOTAL SHEETS	SHEET NO.
8075	03-00167-04-FP	SANGAMON	109	38
STA.	TO STA.			
FED. ROAD DIST. NO.	ILLINOIS	FED. AID PROJECT		

PRIVATE, COMMERCIAL, & FIELD ENTRANCES				
ROADWAY	LOCATION	ANGLE	WIDTH	COMMENT
CARDINAL HILL	468+22.47, RT	78°-07'-25"	16.0'	F.E. SEE DETAIL THIS SHEET
CARDINAL HILL	475+10.00, RT	90°-00'-00"	16.0'	F.E. SEE DETAIL THIS SHEET
CARDINAL HILL	481+51.21, LT	100°-02'-46"	16.0'	F.E. SEE DETAIL THIS SHEET
CARDINAL HILL	495+62.00, LT	90°-00'-00"	16.0'	F.E. SEE DETAIL THIS SHEET
CARDINAL HILL	495+62.00, RT	90°-00'-00"	16.0'	F.E. SEE DETAIL THIS SHEET
CARDINAL HILL	506+25.00, LT	90°-00'-00"	24.0'	C.E. (VILLAGE HALL) SEE SHEET 22
CARDINAL HILL	506+25.00, RT	90°-00'-00"	36.0'	FUTURE STREET SEE SHEET 22
CARDINAL HILL	511+20.00, LT	90°-00'-00"	36.0'	FUTURE STREET SEE SHEET 22
CARDINAL HILL	511+20.00, RT	90°-00'-00"	36.0'	FUTURE STREET SEE SHEET 22
CARDINAL HILL	517+49.00, LT	90°-00'-00"	36.0'	FUTURE STREET SEE SHEET 22
CARDINAL HILL	517+49.00, RT	90°-00'-00"	36.0'	FUTURE STREET SEE SHEET 22
CARDINAL HILL	522+70.00, LT	90°-00'-00"	36.0'	FUTURE STREET SEE SHEET 22
CARDINAL HILL	522+70.00, RT	90°-00'-00"	36.0'	FUTURE STREET SEE SHEET 22
CARDINAL HILL	524+17.78, LT	111°-20'-33"	35.0'	C.E. (FIRE DEPT) SEE SHEET 23
OAK HILL	183+43.70, LT	90°-00'-00"	16.0'	F.E. SEE DETAIL THIS SHEET
OAK HILL	188+63.50, LT	90°-00'-00"	20.5'	P.E. SEE DETAIL THIS SHEET
OAK HILL	188+63.50, RT	90°-00'-00"	16.0'	F.E. SEE DETAIL THIS SHEET
OAK HILL	195+90.00, LT	90°-00'-00"	16.0'	F.E. SEE DETAIL THIS SHEET
WALNUT ST	302+93.40, RT	90°-00'-00"	19.0'	P.E. SEE DETAIL THIS SHEET
WALNUT ST	303+66.60, RT	90°-00'-00"	18.0'	P.E. SEE DETAIL THIS SHEET
WALNUT ST	309+45.40, LT	90°-00'-00"	16.0'	F.E. SEE DETAIL THIS SHEET
BUCKHART RD	4+94.40, LT	92°-56'-52"	16.0'	P.E. SEE DETAIL THIS SHEET
BUCKHART RD	6+68.00, RT	86°-10'-32"	28.0'	C.E. (FIRE DEPT) SEE SHEET 31
BUCKHART RD	7+06.10, LT	92°-55'-45"	24.0'	MAPLE STREET SEE SHEET 31

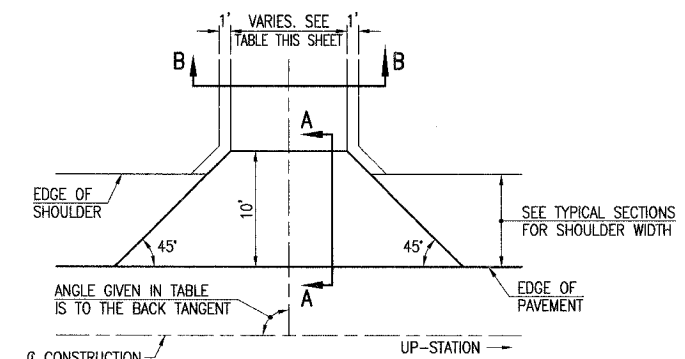

PRIVATE & COMMERCIAL ENTRANCE WITH SHOULDER DETAIL

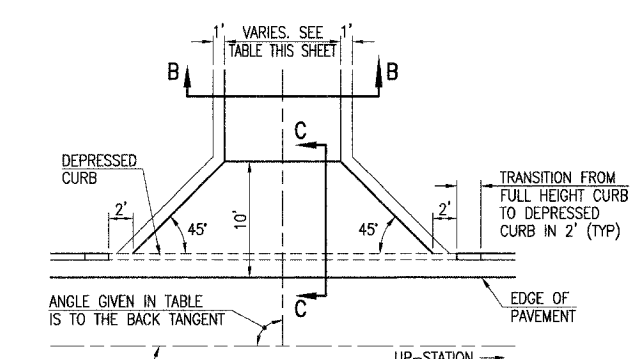

PRIVATE & COMMERCIAL ENTRANCE WITH CURB DETAIL

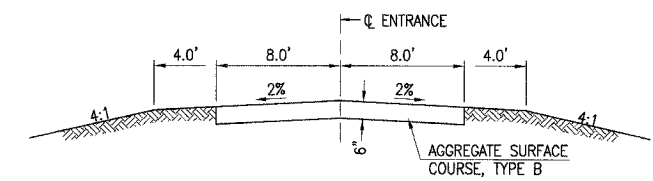

PROPOSED FIELD ENTRANCE SECTION

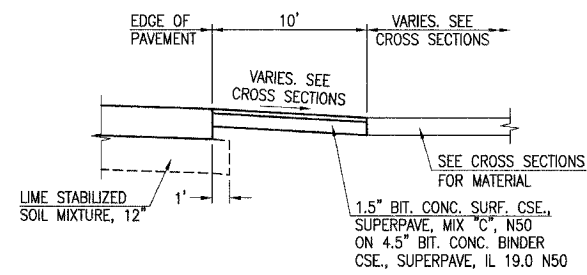

SECTION A-A

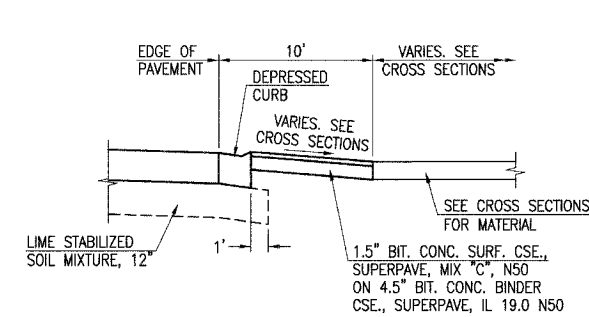

SECTION C-C

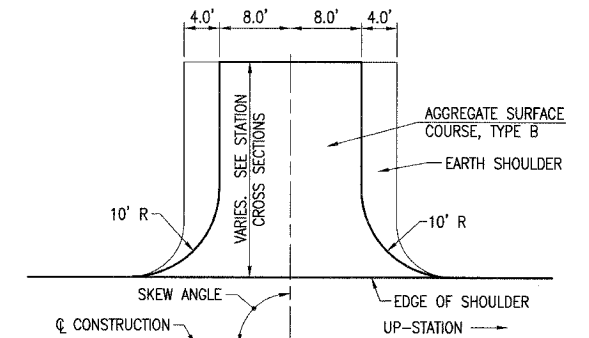

FIELD ENTRANCE WITH SHOULDER DETAIL

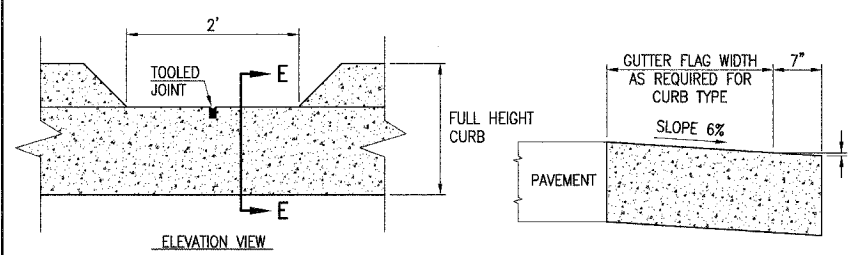

SECTION E-E CURB BREAK DEPRESSED CURB

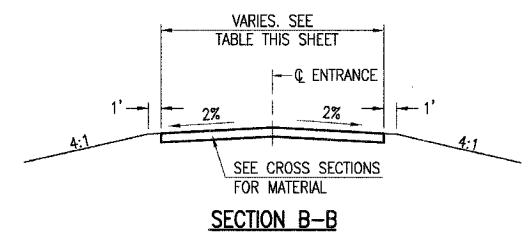

SECTION B-B

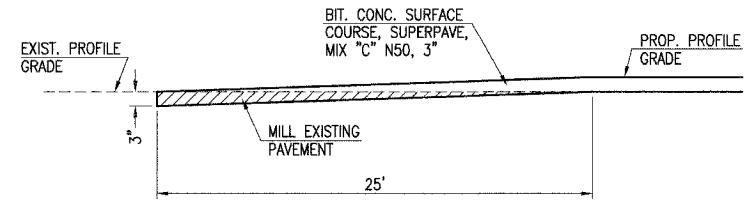

BUTT JOINT DETAIL BUCKHART ROAD

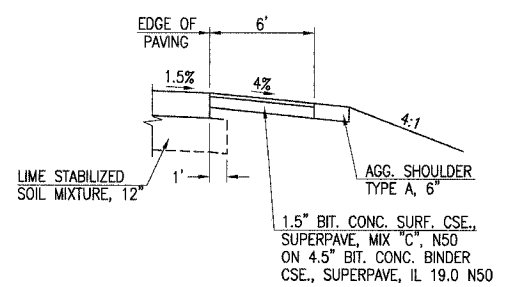

MAILBOX TURNOUT SECTION

- NOTE:
1. THE TRANSITION FROM FULL HEIGHT CURB TO DEPRESSED CURB SHALL BE MADE AT THE RATE OF 3" PER FOOT OF LENGTH OR FLATTER.
 2. DEPRESSED CURB IN THE CURB BREAK SHALL BE CONSTRUCTED TO ALLOW WATER TO FLOW OUT OF THE CURB BREAK WITHOUT ANY PONDING OF THE WATER ON THE PAVEMENT.

CURB BREAK DETAIL

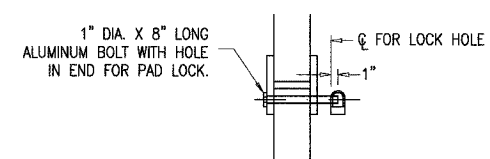

ALL EXCAVATION, BACKFILL, CONCRETE AND PAINT IS INCLUDED IN THE COST OF THE GUARD POST.

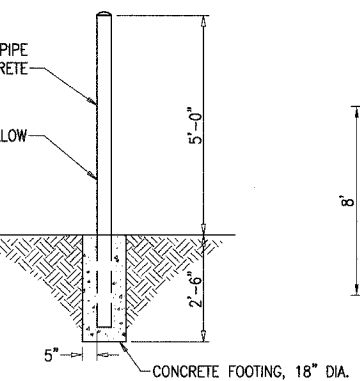

4" DIA. GUARD POST

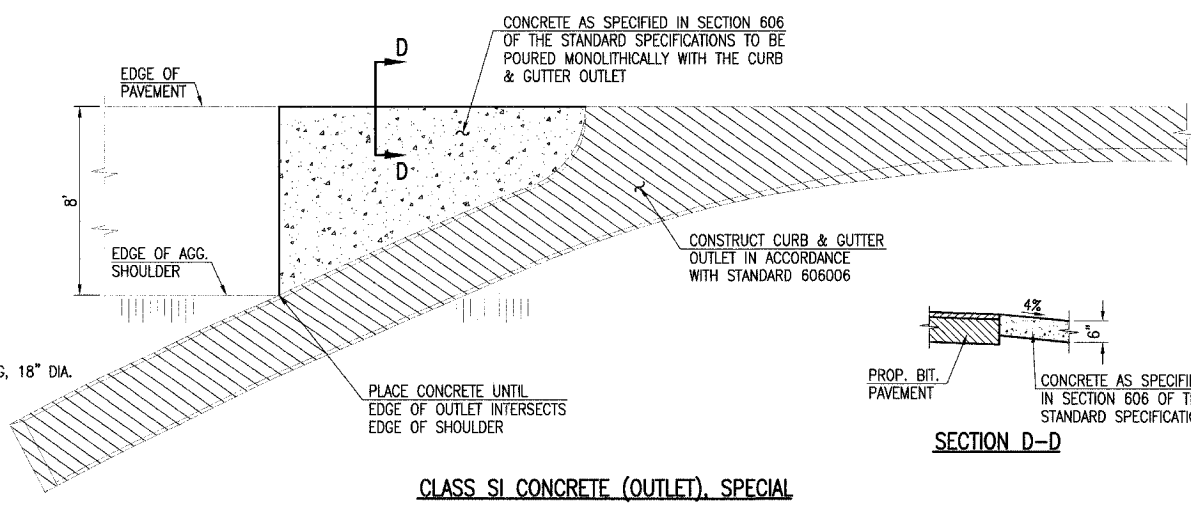

CLASS SI CONCRETE (OUTLET), SPECIAL

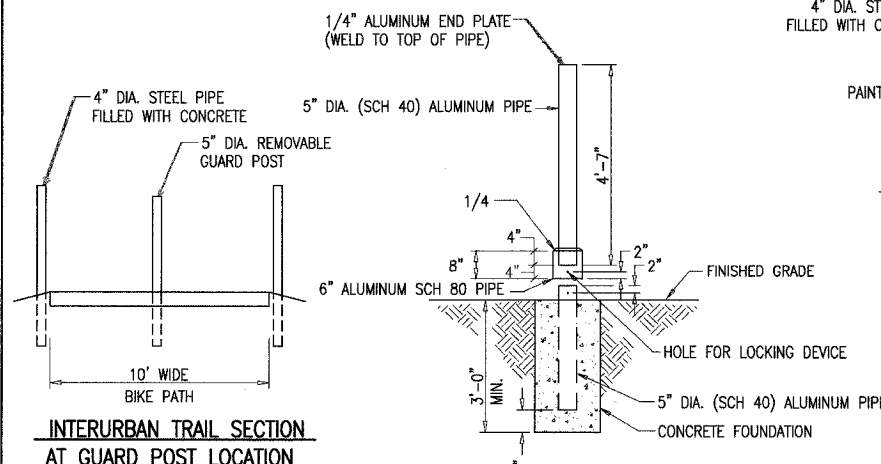

INTERURBAN TRAIL SECTION AT GUARD POST LOCATION

- NOTES:
1. STATION AS SHOWN ON PLANS IS CALLED OUT AT MAILBOX LOCATION.
 2. SEE STANDARD DRAWING B.L.R. 24 FOR PLAN VIEW LAYOUT OF TURNOUT. USE A SHOULDER WIDTH OF 8'.

DETAILS
SEC. 03-00167-04-FP
CARDINAL HILL ROAD (C.H. 37)
SANGAMON COUNTY



Hanson Professional Services Inc.
1525 South Sixth Street, Springfield, IL 62703
Registration No. 164-001064
© Copyright Hanson Professional Services Inc. 2006

JOB NO.
03S2035B
DATE
6/21/06

LAYOUT: 3/15/04
 DRAWN: 3/17/04
 CHECKED: 7/21/04
 IN: 03-00167-04-FP CIVIL SHEET C-50 DET.DWG JUL 21 2006 9:57AM 9:58