

Contract No. 97281

NOTES

Bar splicer assemblies shall be of an approved type and shall develop in tension at least 125 percent of the yield strength of the lapped reinforcement bars.
 Splicer rods shall be of minimum 60 ksi yield strength, threaded or coiled full length.
 All reinforcement bars shall be lapped and tied to the splicer rods or dowel bars.
 Bar splicer assemblies shall be epoxy coated according to the requirements for reinforcement bars.
 Other systems of similar design may be submitted to the Engineer for approval. Approval shall be based on certified test results from an approved testing laboratory that the proposed bar splicer assembly satisfies the following requirements:

- ① Minimum Capacity (Tension in kips) = $1.25 \times f_y \times A_t$
- ② Minimum *Pull-out Strength (Tension in kips) = $1.25 \times f_{s_{allow}} \times A_t$

Where f_y = Yield strength of lapped reinforcement bars in ksi.
 $f_{s_{allow}}$ = Allowable tensile stress in lapped reinforcement bars in ksi (Service Load)
 A_t = Tensile stress area of lapped reinforcement bars.
 * = 28 day concrete

BAR SPLICER ASSEMBLIES			
Bar Size to be Spliced	Splicer Rod or Dowel Bar Length	Strength Requirements	
		Min. Capacity kips - tension	Min. Pull-Out Strength kips - tension
#4	1'-8"	14.7	5.9
#5	2'-0"	23.0	9.2
#6	2'-7"	33.1	13.3
#7	3'-5"	45.1	18.0
#8	4'-6"	58.9	23.6
#9	5'-9"	75.0	30.0
#10	7'-3"	95.0	38.0
#11	9'-0"	117.4	46.8

Bar splicer assemblies shall be according to Section 508 of the Standard Specifications, except as noted. The furnishing and installation of bar splicer assemblies will be measured and paid for at the contract unit price each for "BAR SPLICERS."

The diameter of this part is the same as the diameter of the bar spliced.

The diameter of this part is equal or larger than the diameter of bar spliced.

ROLLED THREAD DOWEL BAR



**** ONE PIECE**

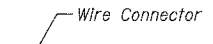

WELDED SECTIONS

BAR SPLICER ASSEMBLY ALTERNATIVES

** Heavy Hex Nuts conforming to ASTM A 563, Grade C, D or DH may be used.

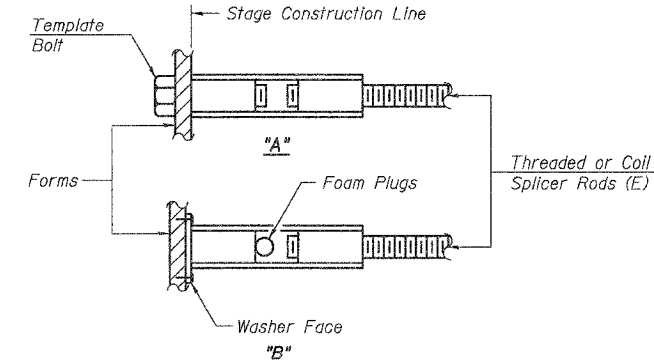

INSTALLATION AND SETTING METHODS

"A" : Set bar splicer assembly by means of a template bolt.
 "B" : Set bar splicer assembly by nailing to wood forms or cementing to steel forms.
 (E) : Indicates epoxy coating.

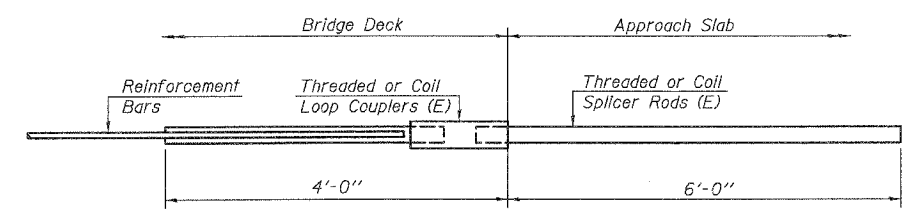

FOR INTEGRAL OR SEMI-INTEGRAL ABUTMENTS

Bar Splicer for #5 bar
Min. Capacity = 23.0 kips - tension
Min. Pull-out Strength = 9.2 kips - tension
No. Required =

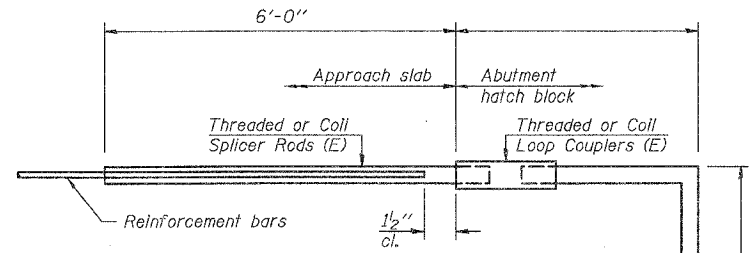

FOR PILE BENT ABUTMENTS

Bar Splicer for #5 bar
Min. Capacity = 23.0 kips - tension
Min. Pull-out Strength = 9.2 kips - tension
No. Required =

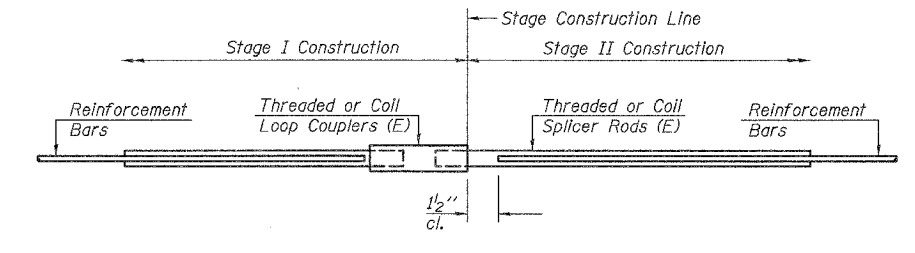

STANDARD

Bar Size	No. Assemblies Required	Location
#5	135	Staged Const. Jt.
#6	2	N. Abut. Diaph.
#6	2	S. Abut. Diaph.

BAR SPLICER DETAILS
 HUMBERT ROAD OVER
 BLACK CREEK
 SECTION 05-00221-00-BR
 CITY OF ALTON
 STA. 278+31.50
 STRUCTURE NO. 060-3023