

EXISTING FINSTAD DR.  
STA. 7+50.00 TO STA. 9+34.12

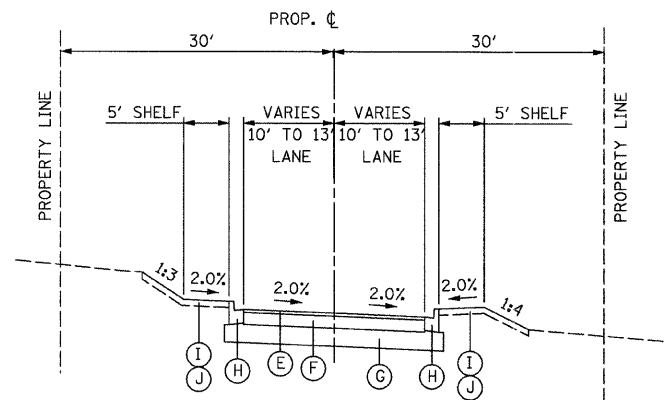

PROPOSED FINSTAD DR.  
STA. 7+50.00 TO STA. 9+34.12

**LEGEND**

- (A) EXISTING BITUMINOUS PAVEMENT
- (B) EXISTING COMB. CONC. CURB AND GUTTER
- (C) EXISTING AGGREGATE SHOULDER
- (D) PROP. RETAINING WALL WITH RAILING
- (E) PROP. HOT-MIX ASPHALT SURFACE COURSE, MIX "D", N50 (IL 9.5 mm), 2"
- (F) PROP. HOT-MIX ASPHALT BINDER COURSE, IL-19.0, N50, 8" (2 LIFTS)
- (G) PROP. AGGREGATE SUBGRADE, 12"
- (H) PROP. B-6.12 COMB. CONC. CURB AND GUTTER
- (I) PROP. FURNISHING AND PLACING TOPSOIL, 4"
- (J) PROP. SEEDING AND EROSION CONTROL BLANKET
- (K) PROP. AGGREGATE SHOULDER, TYPE A 12"
- (L) PROP. B-6.24 COMB. CONC. CURB AND GUTTER

FILE NAME = s:\102901\cadd sheets\sh-typical12.dgn	USER NAME = IDOT	DESIGNED - EJM	REVISED -
		DRAWN - BK	REVISED -
		CHECKED - GFL	REVISED -
		DATE - 12/17/10	REVISED -

**STATE OF ILLINOIS  
DEPARTMENT OF TRANSPORTATION**

**EXISTING & PROPOSED TYPICAL SECTIONS  
FINSTAD DRIVE**

SCALE: SHEET NO. OF SHEETS STA. TO STA.

F.A.P. RTE. 330	SECTION 120R-3	COUNTY LAKE	TOTAL SHEETS 518	SHEET NO. 32
CONTRACT NO. 60953				
FED. ROAD DIST. NO. 1   ILLINOIS   FED. AID PROJECT				