

COMBINATION CURB AND GUTTER TRANSITION
N.T.S.

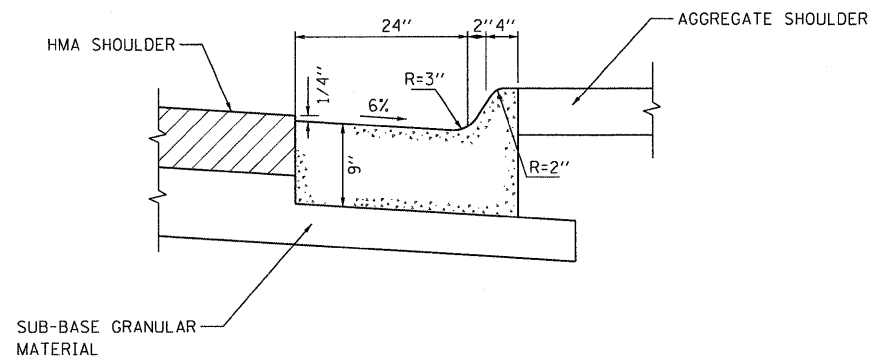

SECTION A-A
N.T.S.

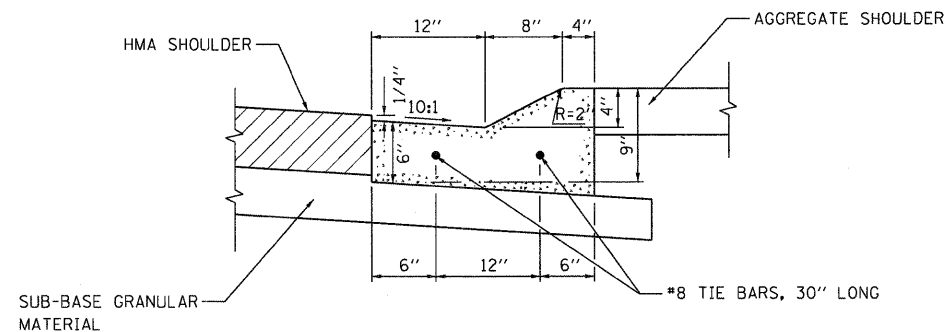

SECTION B-B
N.T.S.

NOTES:

1. TRANSITION FROM PROPOSED COMBINATION CONCRETE CURB AND GUTTER TYPE M-2.24 TO EXISTING ISTHA TYPE G-2 GUTTER SHALL BE IN 10' AND SHALL BE PAID AS FOR COMBINATION CONCRETE CURB AND GUTTER TYPE M-2.24.
2. FOR MORE INFORMATION ON COMBINATION CONCRETE CURB AND GUTTER TYPE M-2.24 SEE STANDARD 606001.
3. THE COST OF GROUTED-IN-PLACE #8 TIE BARS SHALL BE INCLUDED IN THE COST OF COMBINATION CONCRETE CURB AND GUTTER TYPE M-2.24.

FILE NAME = 62099CDE101.DGN	USER NAME = helated	DESIGNED - PK	REVISED -	STATE OF ILLINOIS DEPARTMENT OF TRANSPORTATION	ILLINOIS RTE 1 OVER TRI-STATE I-80 / I-294 DETAILS	F.A.P. RTE. 876	SECTION 2001-001BR	COUNTY COOK	TOTAL SHEETS 62	SHEET NO. 19	
PLOT SCALE = 50.000' / 1"	CHECKED - RPI	REVISIED -	REVISIED -			SCALE: NONE	SHEET NO. OF SHEETS	STA. TO STA.	CONTRACT NO. 62099		
PLOT DATE = 6/28/2011	DATE - 07/01/2011	REVISIED -	REVISIED -			FED. ROAD DIST. NO. 1 [ILLINOIS] FED. AID PROJECT					