

POSITION OF HANDHOLE AND POLE NUMBER FOR SINGLE MAST ARM POLES

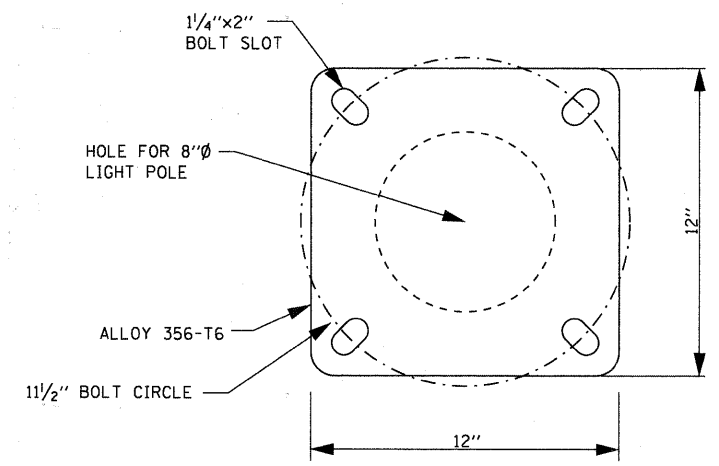

LIGHT POLE BASE PLATE DETAIL 11 1/2 INCH BOLT CIRCLE

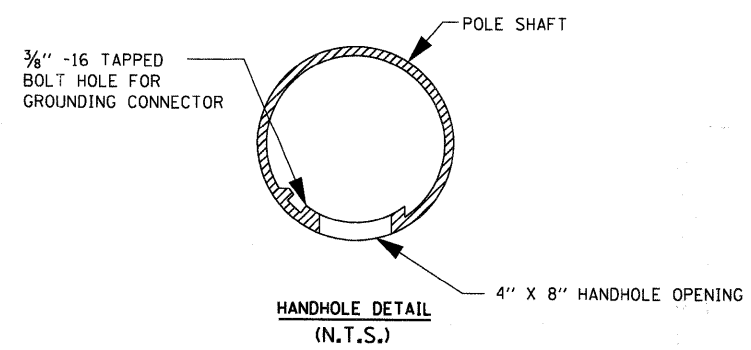

- NOTES:**
1. ALL DIMENSIONS ARE IN MILLIMETERS (INCHES) UNLESS OTHERWISE SHOWN.
 2. MOUNTING HEIGHT IS DEFINED AS THE DISTANCE FROM THE CENTERLINE OF THE TENON TO THE BOTTOM OF THE ANCHOR BASE.
 3. THE LIGHT POLE WILL MEET AASHTO DESIGN CRITERIA AS SPECIFIED.
 4. THE INSTALLING CONTRACTOR WILL PROVIDE A UL LISTED GROUNDING CONNECTOR, BURNDY K2C23, T & B SP4DL OR APPROVED EQUAL.
 5. LIGHT POLES WILL NOT BE INSTALLED WITHOUT MAST ARMS AND LUMINAIRES.
 6. LIGHT POLES WILL BE SET PLUMB ON THE FOUNDATION WITHOUT THE USE OF LEVELING NUTS, WASHERS OR SHIMS.
 7. LIGHTING UNIT IDENTIFICATION NUMBERS SHALL BE INSTALLED BEFORE THE LIGHTING UNIT IS ENERGIZED.
 8. POLE SHALL BE LISTED PER UL OR ETL OR APPROVED EQUIVALENT TESTING LABORATORY.

FILE NAME =	USER NAME = #USER#	DESIGNED - BL	REVISED -
#FILE#		DRAWN - RV	REVISED -
	PLOT SCALE = #SCALE#	CHECKED - MSA	REVISED -
	PLOT DATE = #DATE#	DATE - 06-17-11	REVISED -

STATE OF ILLINOIS
DEPARTMENT OF TRANSPORTATION

LIGHTING DETAILS				
SCALE:	SHEET NO.	OF SHEETS	STA.	TO STA.

F.A.P. RTE.	SECTION	COUNTY	TOTAL SHEETS	SHEET NO.
3513	10-00-111-00-LS	COOK	62	36
CONTRACT NO. 63622				
ILLINOIS FED. AID PROJECT				

LTG-08

AMES Engineering, Inc.
CONSULTING ENGINEERS
1341 Warren Avenue
Downers Grove, IL 60515
(630) 737-1987 (F); (630) 470-9891 (T)
www.amesengineeringinc.com