

MILLED TEMPORARY RAMP  
(FOR BUTT JOINT AND HMA TAPER SEE DETAIL BELOW)

OPTION 1

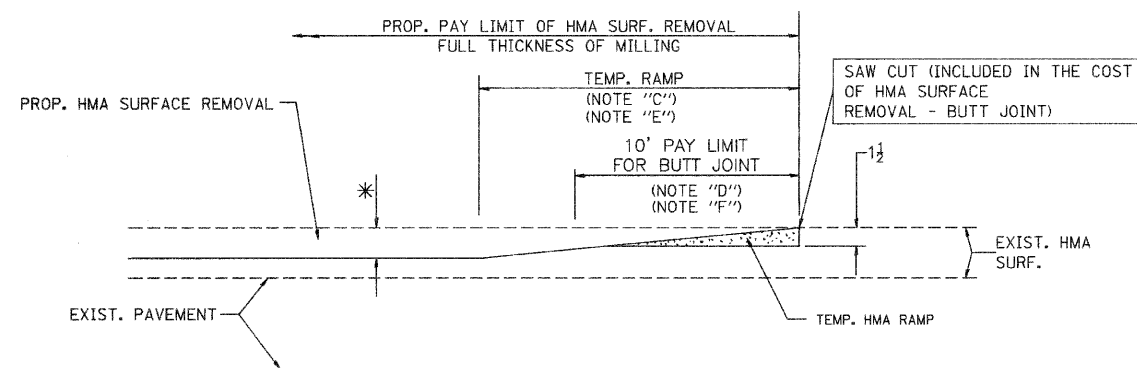

HMA CONSTRUCTED TEMPORARY RAMP  
(FOR BUTT JOINT AND HMA TAPER SEE DETAIL BELOW)

OPTION 2

TYPICAL TEMPORARY RAMP

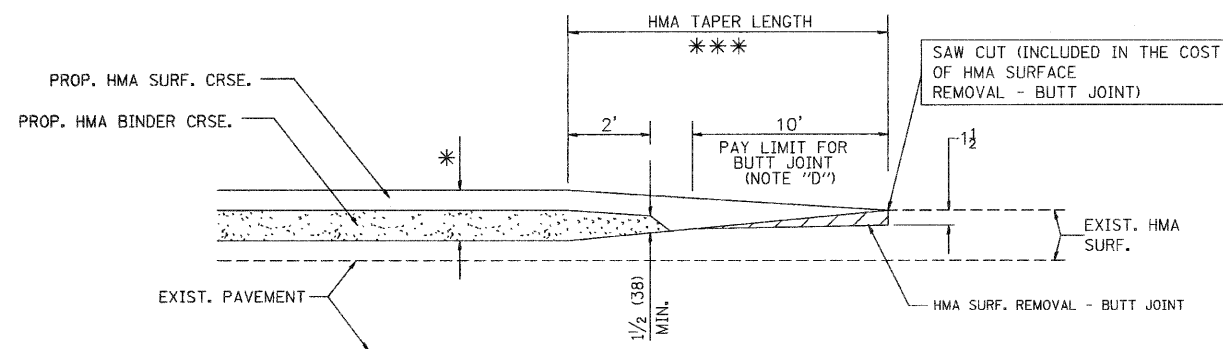

BUTT JOINT AND HMA TAPER  
TYPICAL BUTT JOINT AND HMA TAPER  
FOR MILLING AND RESURFACING

NOTES

- A: MAINLINE ROADWAYS AND MAJOR SIDE ROADS.
- B: MINOR SIDE ROADS.
- C: THE TEMP. RAMP SHALL BE CONSTRUCTED IMMEDIATELY UPON REMOVAL OF THE EXISTING HMA SURFACE.
- D: THE BUTT JOINT SHALL BE CONSTRUCTED IMMEDIATELY PRIOR TO PLACING THE PROPOSED HMA COURSES.
- E: TAPER THE TEMP. RAMP AT A RATE OF 3'-0" (900 mm) PER 1 INCH (25 mm) OF MILLING THICKNESS.
- F: INSTALLATION AND REMOVAL OF THE 4'-6" (1.35 m) TEMP. RAMP IS INCLUDED IN COST OF HMA SURFACE REMOVAL - BUTT JOINT
- G: SEE ARTICLE 406.08 AND 406.14 OF THE STANDARD SPECIFICATIONS FOR "HMA AND/OR PCC SURFACE REMOVAL, BUTT JOINT".
- \* SEE TYPICAL SECTIONS FOR MILLING THICKNESS.
- \*\*\* 20'-0" (6.1 m) PER 1 (25) RESURFACING (NOTE "A")  
10'-0" (3.0 m) PER 1 (25) RESURFACING (NOTE "B")

BASIS OF PAYMENT:

THE BUTT JOINT WILL BE PAID FOR AT THE CONTRACT UNIT PRICE PER SQUARE YARD (SQUARE METER) FOR "HOT-MIX ASPHALT SURFACE REMOVAL - BUTT JOINT" OR FOR "PORTLAND CEMENT CONCRETE SURFACE REMOVAL - BUTT JOINT".

ALL DIMENSIONS ARE IN INCHES (MILLIMETERS) UNLESS OTHERWISE SHOWN.

FILE NAME = 06328-DTLS-04 - RD-32

USER NAME =	DESIGNED -- RW	REVISED --
	CHECKED -- RW	REVISED --
PLOT SCALE =	DRAWN -- SLG	REVISED --
PLOT DATE = 01-25-10	CHECKED -- AG	REVISED --

STATE OF ILLINOIS  
DEPARTMENT OF TRANSPORTATION

US ROUTE 6 (RIVER OAKS DRIVE) AT PAXTON AVENUE  
INTERSECTION IMPROVEMENT  
CONSTRUCTION DETAILS

F.A.P. RTE.	SECTION	COUNTY	TOTAL SHEETS	SHEET NO.
351	06-00139-00-CH	COOK	044	027
CONTRACT NO. 63288				
FED. ROAD DIST. NO. 1	ILLINOIS	FED. AID PROJECT	HD-M-9003(258)	

SCALE: NONE SHEET NO. 027 OF 044 SHEETS STA. TO STA.