

STATE OF ILLINOIS
DEPARTMENT OF TRANSPORTATION

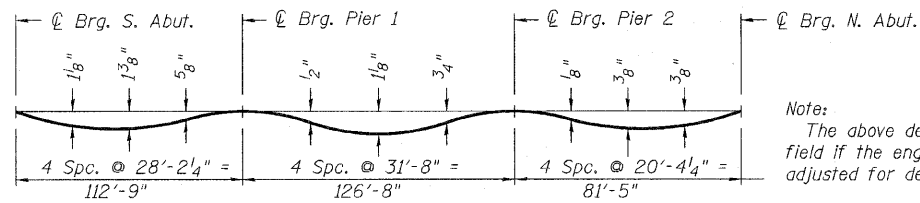

DEAD LOAD DEFLECTION DIAGRAM

(Includes weight of concrete only.)

Note:
The above deflections are not to be used in the field if the engineer is working from the grade elevations adjusted for dead load deflections as shown below.

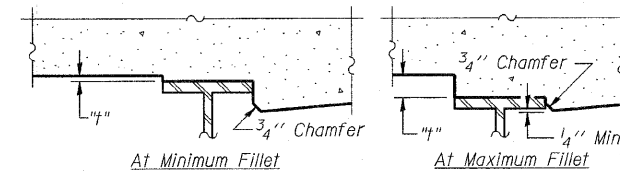

To determine "t": After all structural steel has been erected, elevations of the top flanges of the beams shall be taken at intervals shown below. These elevations subtracted from the "Theoretical Grade Elevations Adjusted for Dead Load Deflection" shown below, minus slab thickness, equals the fillet heights "t" above top flange of beams.

FILLET HEIGHTS

GIRDER 1

Location	Station	Offset	Theoretical Grade Elevations	Theoretical Grade Elevations Adjusted For Dead Load Deflection
Bk. of S. Abut.	597+99.86	-18.27	744.30	744.30
Brg. S. Abut.	598+06.01	-18.22	744.36	744.36
A	598+15.88	-18.19	744.45	744.49
B	598+25.75	-18.22	744.53	744.61
C	598+35.63	-18.33	744.61	744.71
D	598+45.56	-18.50	744.67	744.79
E	598+55.56	-18.67	744.72	744.84
F	598+65.56	-18.84	744.76	744.88
G	598+75.56	-19.02	744.79	744.88
H	598+85.55	-19.19	744.80	744.87
I	598+95.55	-19.25	744.80	744.85
J	599+05.55	-19.25	744.78	744.81
Q Pier 1	599+21.28	-19.25	744.74	744.74
K	599+31.28	-19.25	744.72	744.72
L	599+41.28	-19.25	744.70	744.72
M	599+51.28	-19.25	744.68	744.72
N	599+61.28	-19.25	744.67	744.73
O	599+71.28	-19.25	744.66	744.74
P	599+81.28	-19.25	744.64	744.73
Q	599+91.28	-19.25	744.60	744.70
R	600+01.28	-19.25	744.56	744.65
S	600+11.28	-19.25	744.51	744.58
T	600+21.28	-19.25	744.44	744.49
U	600+31.28	-19.25	744.36	744.39
V	600+41.28	-19.25	744.27	744.28
Q Pier 2	600+47.93	-19.25	744.21	744.21
W	600+57.93	-19.25	744.10	744.10
X	600+67.93	-19.25	743.98	743.99
Y	600+77.93	-19.25	743.85	743.87
Z	600+87.93	-19.25	743.71	743.74
AA	600+97.93	-19.25	743.56	743.59
AB	601+07.93	-19.25	743.39	743.42
AC	601+17.93	-19.25	743.22	743.24
Brg. of N. Abut.	601+29.36	-19.25	742.02	743.02
Bk. of N. Abut.	601+35.36	-19.25	742.91	742.91

GIRDER 2

Location	Station	Offset	Theoretical Grade Elevations	Theoretical Grade Elevations Adjusted For Dead Load Deflection
Bk. of S. Abut.	597+84.44	-11.30	743.73	743.73
Brg. S. Abut.	597+90.61	-11.18	743.85	743.85
A	598+00.53	-11.04	743.98	744.02
B	598+10.46	-10.97	744.10	744.17
C	598+20.38	-11.97	744.22	744.32
D	598+30.30	-11.03	744.32	744.44
E	598+40.23	-11.17	744.42	744.54
F	598+50.22	-11.35	744.51	744.62
G	598+60.22	-11.52	744.58	744.68
H	598+70.22	-11.70	744.64	744.72
I	598+80.22	-11.75	744.69	744.74
J	598+90.22	-11.75	744.72	744.75
Q Pier 1	599+05.94	-11.75	744.76	744.76
K	599+15.94	-11.75	744.76	744.76
L	599+25.94	-11.75	744.76	744.77
M	599+35.94	-11.75	744.74	744.78
N	599+45.94	-11.75	744.74	744.80
O	599+55.94	-11.75	744.74	744.83
P	599+65.94	-11.75	744.74	744.84
Q	599+75.94	-11.75	744.72	744.82
R	599+85.94	-11.75	744.70	744.79
S	599+95.94	-11.75	744.66	744.74
T	600+05.94	-11.75	744.61	744.66
U	600+15.94	-11.75	744.55	744.58
V	600+25.94	-11.75	744.48	744.49
Q Pier 2	600+32.59	-11.75	744.43	744.43
W	600+42.59	-11.75	744.34	744.33
X	600+52.59	-11.75	744.23	744.24
Y	600+62.59	-11.75	744.12	744.14
Z	600+72.59	-11.75	744.00	744.02
AA	600+82.59	-11.75	743.86	743.89
AB	600+92.59	-11.75	743.72	743.74
AC	601+02.59	-11.75	743.56	743.57
Brg. of N. Abut.	601+14.02	-11.75	743.36	743.36
Bk. of N. Abut.	601+20.02	-11.75	743.26	743.26

GIRDER 3

Location	Station	Offset	Theoretical Grade Elevations	Theoretical Grade Elevations Adjusted For Dead Load Deflection
Bk. of S. Abut.	597+69.08	-4.59	743.09	743.09
Brg. S. Abut.	597+75.27	-4.39	743.20	743.20
A	597+85.24	-4.13	743.39	743.43
B	597+95.21	-3.95	743.56	743.64
C	598+05.18	-3.83	743.72	743.82
D	598+15.15	-3.78	743.87	743.98
E	598+25.13	-3.80	744.01	744.13
F	598+35.10	-3.89	744.14	744.26
G	598+45.08	-4.04	744.26	744.36
H	598+55.08	-4.20	744.37	744.45
I	598+65.08	-4.25	744.46	744.51
J	598+75.08	-4.25	744.55	744.57
Q Pier 1	598+90.59	-4.25	744.65	744.65
K	599+00.59	-4.25	744.70	744.70
L	599+10.59	-4.25	744.74	744.76
M	599+20.59	-4.25	744.78	744.81
N	599+30.59	-4.25	744.79	744.86
O	599+40.56	-4.25	744.80	744.89
P	599+50.59	-4.25	744.82	744.91
Q	599+60.59	-4.25	744.82	744.92
R	599+70.59	-4.25	744.81	744.90
S	599+80.59	-4.25	744.79	744.86
T	599+90.59	-4.25	744.76	744.81
U	600+00.59	-4.25	744.71	744.74
V	600+10.59	-4.25	744.66	744.67
Q Pier 2	600+17.24	-4.25	744.62	744.62
W	600+27.24	-4.25	744.55	744.54
X	600+37.24	-4.25	744.46	744.47
Y	600+47.24	-4.25	744.37	744.38
Z	600+57.24	-4.25	744.26	744.28
AA	600+67.24	-4.25	744.14	744.17
AB	600+77.24	-4.25	744.01	744.04
AC	600+87.24	-4.25	743.87	743.89
Brg. of N. Abut.	600+98.67	-4.25	743.70	743.70
Bk. of N. Abut.	601+04.67	-4.25	743.60	743.60

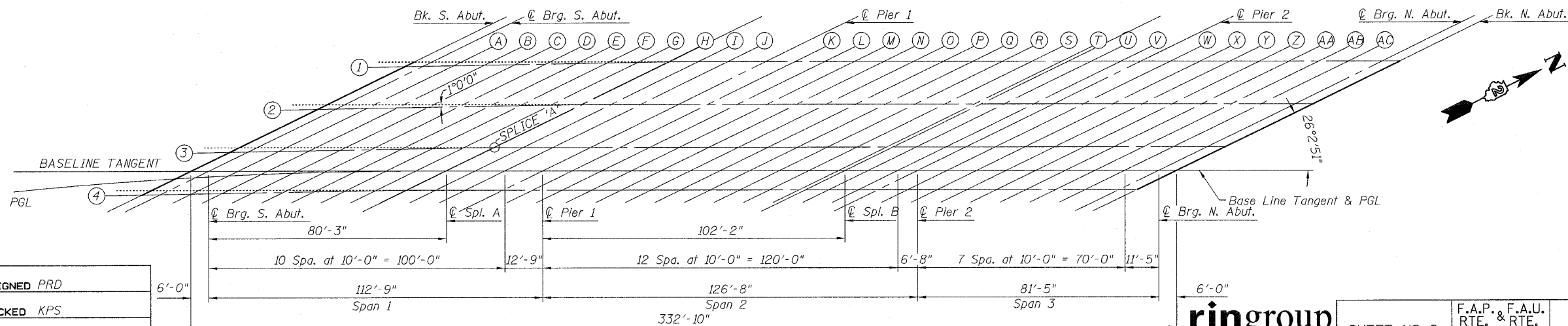

PLAN

**TOP OF SLAB ELEVATIONS
STRUCTURE NO. 101-0123**

DESIGNED	PRD
CHECKED	KPS
DRAWN	PRD
CHECKED	KPS

rjngroup
Excellence through Ownership
200 West Front Street
Wheaton, IL 60187
PH. 630.682.4700

SHEET NO. 3 OF 33 SHEETS	F.A.P. & F.A.U. RTE. & RTE.	SECTION	COUNTY	TOTAL SHEETS	SHEET NO.
	303 5146	1-HBR & 1-2HB-D	WINNEBAGO	216	119
CONTRACT NO. 64B79					
FED. ROAD DIST. NO. 2 ILLINOIS FED. AID PROJECT					