

INLET SPECIAL

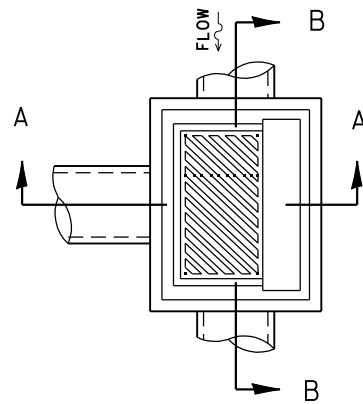
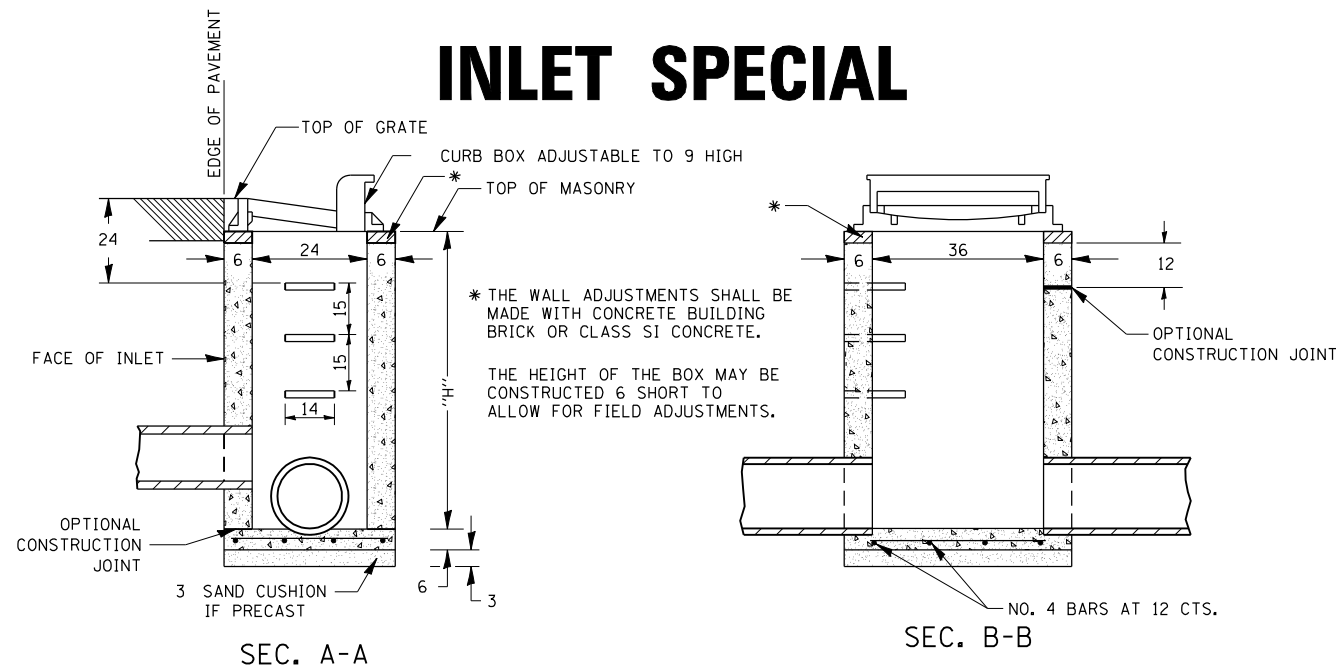

DETAIL OF FRAME & GRATE

NOTES

CLASS SI CONCRETE OR PRECAST CONCRETE SHALL BE USED THROUGHOUT. PRECAST CONCRETE SHALL BE IN ACCORDANCE WITH SECTION 504.01 THRU 504.05 OF THE STANDARD SPECIFICATIONS EXCEPT THAT CONCRETE STRENGTH SHALL BE 4,000 psi AFTER 28 DAYS.

THE CONTRACT UNIT PRICE EACH FOR INLET SPECIAL SHALL INCLUDE THE COST OF CONSTRUCTING THE INLET BOX, FURNISHING AND INSTALLING THE FRAME AND GRATE, THE CAST IRON STEPS (IF USED), THE PRECAST FLOOR SLABS, SAND CUSHION (WHEN USED) AND REINFORCEMENT BARS.

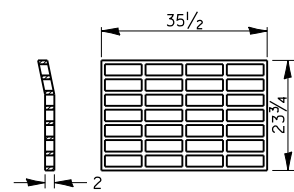

PLAN OF GRATE *

* THIS GRATE TO BE USED WITHOUT CURB BOX WHEN INLET IS IN DRIVEWAY.

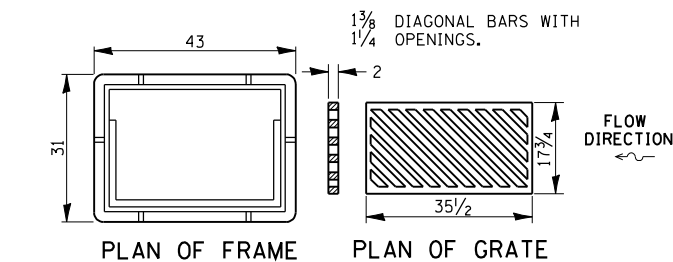

PLAN OF FRAME

PLAN OF GRATE

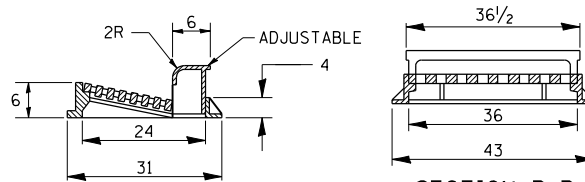

SECTION A-A

SECTION B-B

ALL DIMENSIONS ARE IN INCHES UNLESS OTHERWISE NOTED.

INLET SPECIAL NO. 2

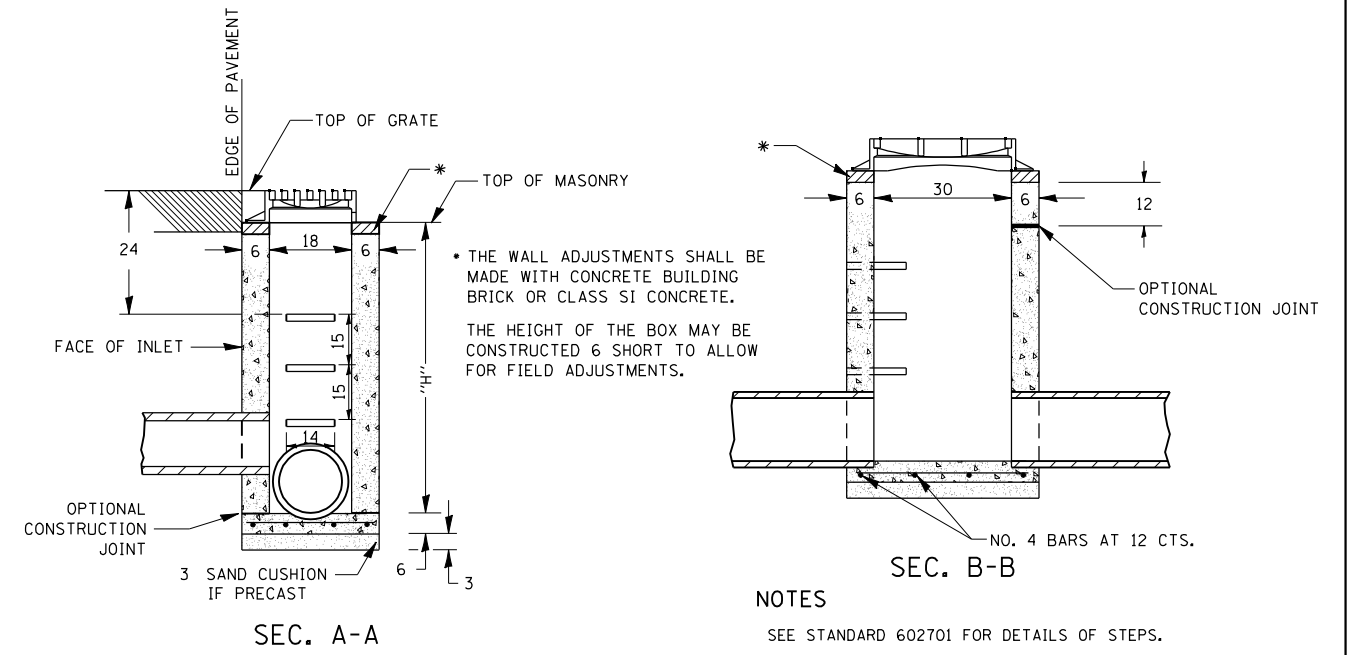

NOTES

- SEE STANDARD 602701 FOR DETAILS OF STEPS.
- EXCEPT AS NOTED HEREON INLET SPECIAL SHALL BE CONSTRUCTED IN ACCORDANCE WITH SECTION 602 OF THE STANDARD SPECIFICATIONS.
- THE SIDE WALLS MAY BE BUILT AS PRECAST SEGMENTED SECTIONS.
- ALL VOIDS AROUND PIPE ENTRANCE, BOTH INSIDE AND OUTSIDE, SHALL BE SEALED WITH MORTAR.
- STEPS SHALL BE OMITTED WHEN DEPTH OF "H" IS LESS THAN 5 FOOT.
- INLET SPECIAL NO. 2 SHALL MATCH THE EXISTING STORM SEWER AS SHOWN ON THE PLANS.

DETAIL OF FRAME & GRATE

NOTES

CLASS SI CONCRETE OR PRECAST CONCRETE SHALL BE USED THROUGHOUT. PRECAST CONCRETE SHALL BE IN ACCORDANCE WITH SECTION 504.01 THRU 504.05 OF THE STANDARD SPECIFICATIONS EXCEPT THAT CONCRETE STRENGTH SHALL BE 4,000 psi AFTER 28 DAYS.

THE CONTRACT UNIT PRICE EACH FOR INLET SPECIAL NO.2 SHALL INCLUDE THE COST OF CONSTRUCTING THE INLET BOX, FURNISHING AND INSTALLING THE FRAME AND GRATE, THE CAST IRON STEPS (IF USED), THE PRECAST FLOOR SLABS, SAND CUSHION (WHEN USED) REINFORCEMENT BARS, AND REMOVAL OF ANY EXCESS STORM SEWER..

NEENAH - R-3461 OR EQUIVALENT

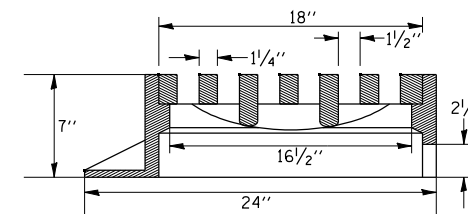

SEC. A-A

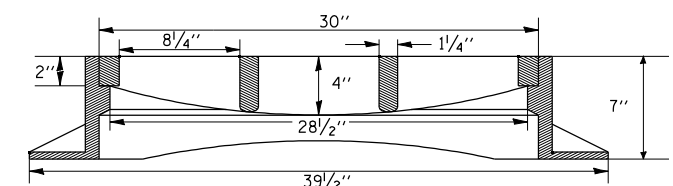

SEC. B-B

REVISED - 10-13-11

REVISED - 10-14-11
REVISED -
REVISED -
REVISED -

REGION 2 / DISTRICT 2 STANDARD

SCALE: 102.3636 "/ IN. SHEET NO. 2 OF 12 SHEETS STA. TO STA.

F.A.P. RTE.	SECTION	COUNTY	TOTAL SHEETS	SHEET NO.
308	103BR-4	JO DAVIESS	159	150
FED. ROAD DIST. NO.			ILLINOIS FED. AID PROJECT	
			CONTRACT NO. 64E08	

PLOT DATE = 8/5/2013