

F.A.P. RTE.	SECTION	COUNTY	TOTAL SHEETS	SHEET NO.
885	112B-1	POPE	56	1
FED. ROAD DIST. NO.	ILLINOIS	CONTRACT NO. 78230		

SHEET NO. DESCRIPTION

- ROADWAY PLANS**
- COVER SHEET
  - GENERAL NOTES AND STANDARDS
  - 8. SUMMARY OF QUANTITIES
  - 12. TYPICAL SECTIONS
  - SCHEDULES OF QUANTITIES
  - 16. IL ROUTE PLAN AND PROFILE
  - 18. STAGE CONSTRUCTION PLAN AND DETAILS
  - EROSION CONTROL PLAN
  - SEEDING AND MULCHING DETAILS
  - STEP CONSTRUCTION ON EXISTING FILL DETAILS
  - BUTT JOINT DETAIL
- STRUCTURE PLANS**
- GENERAL PLAN & ELEVATION
  - GENERAL DATA
  - STAGE CONSTRUCTION DETAILS
  - TEMPORARY CONCRETE BARRIER FOR STAGE CONSTRUCTION
  - TOP OF SLAB ELEVATIONS
  - TOP OF WEST APPROACH SLAB ELEVATIONS
  - TOP OF EAST APPROACH SLAB ELEVATIONS
  - SUPERSTRUCTURE
  - 31.-32. SUPERSTRUCTURE DETAILS
  - 33.-34. BRIDGE APPROACH SLAB DETAILS
  - DRAINAGE SCUPPER, DS-12M10
  - WEST ABUTMENT
  - EAST ABUTMENT
  - PIER 1
  - PIER 2
  - HP PILE DETAILS
  - BAR SPLICER ASSEMBLY DETAILS
  - BORING LOGS
- EXISTING STRUCTURE PLANS**  
SN 076-0009
- 44.-51. EXISTING STRUCTURE PLANS - FOR INFORMATION ONLY
- CROSS SECTIONS**
- 52.-56. IL RTE 146 CROSS SECTIONS

STATE OF ILLINOIS  
DEPARTMENT OF TRANSPORTATION  
DIVISION OF HIGHWAYS

**PROPOSED  
HIGHWAY PLANS**

FAP ROUTE 885 (IL 146)  
SECTION 112B-1  
PROJECT ACF-0885(048)  
POPE COUNTY

C - 99 - 009 - 11

BRIDGE REPLACEMENT  
OVER FLAT LICK BRANCH

R5E, 3RD PM



FUNCTIONAL CLASSIFICATION: MINOR ARTERIAL (NON URBAN)  
DESIGN SPEED: 55 mph  
POSTED SPEED: 55 mph  
ADT: 1,870 (2011)  
PV: 93.8%  
TRUCKS: 6.2%  
TOWNSHIP: ROAD DISTRICT NO. 2

DESIGN  
DESIGNATION  
N.A.

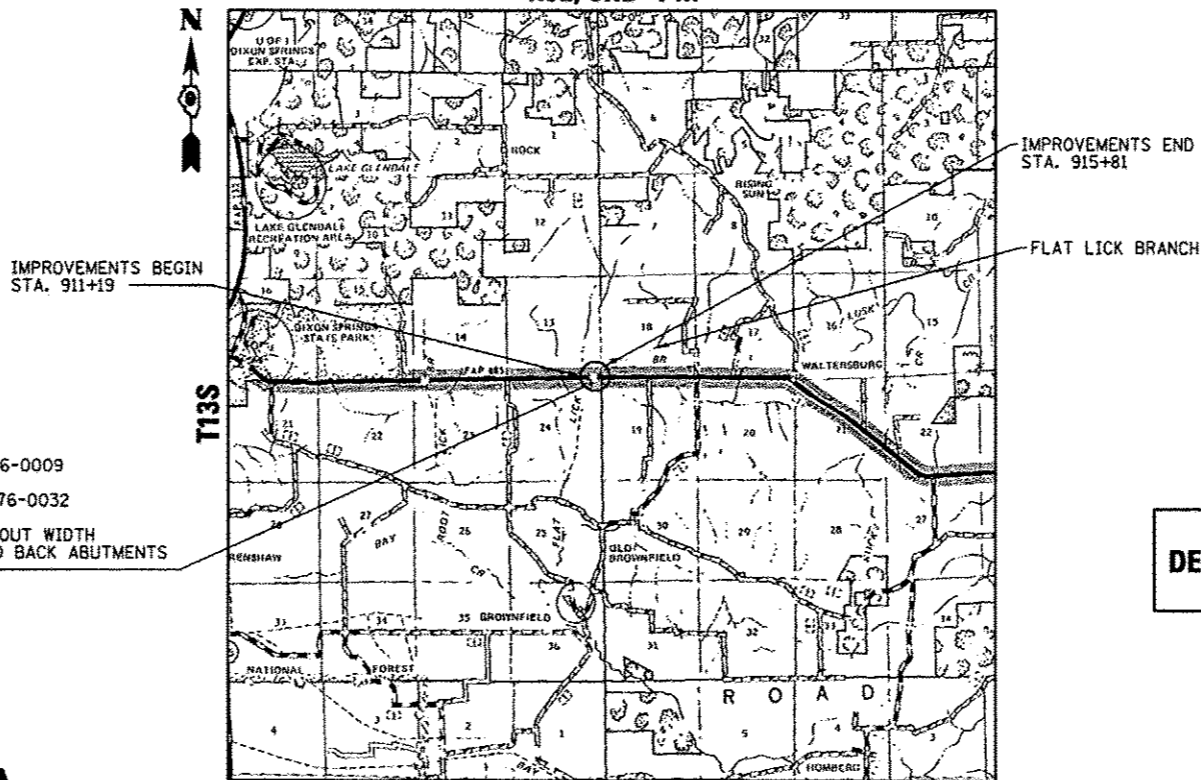

LOCATION MAP

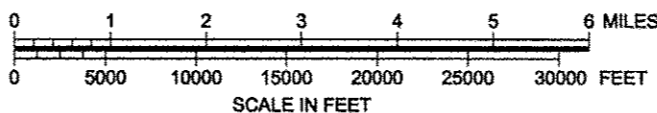

EXISTING SN 076-0009  
STA. 913+50.00  
PROPOSED SN 076-0032  
STA. 913+50.00  
35'-2" OUT TO OUT WIDTH  
101'-0" BACK TO BACK ABUTMENTS  
(0° SKEW)



Richard D. Payne  
DATE: 08/05/2013  
ILLINOIS PROFESSIONAL LICENSE NO. 37421  
(EXPIRATION DATE: 11-30-13)

GROSS LENGTH = 462 FT. = 0.088 MI.  
NET LENGTH = 462 FT. = 0.088 MI.

J.U.L.I.E.  
JOINT UTILITY LOCATION INFORMATION FOR EXCAVATION  
1-800-892-0123  
OR 811

DISTRICT 9 NO. (618) 549-2171  
PROJECT ENGINEER: DAVID PICHE  
CONTRACT NO. 78230

STATE OF ILLINOIS  
DEPARTMENT OF TRANSPORTATION  
DIVISION OF HIGHWAYS

SUBMITTED August 14 20 13  
Deputy Director of Highways, Region Engineer  
October 4 20 13  
John D. Balanzoni, PE  
Assistant Engineer of Design and Environment  
October 4 20 13  
Omer Osman, PE  
DIRECTOR OF HIGHWAYS, CHIEF ENGINEER

PRINTED BY THE AUTHORITY  
OF THE STATE OF ILLINOIS

**LIST OF ILLINOIS DOT HIGHWAY STANDARDS**

STANDARD NO.	DESCRIPTION
000001-06	STANDARD SYMBOLS, ABBREVIATIONS AND PATTERNS
001001-02	AREAS OF REINFORCEMENT BARS
001006	DECIMAL OF AN INCH AND OF A FOOT
280001-07	TEMPORARY EROSION CONTROL SYSTEMS
420001-07	PAVEMENT JOINTS
420401-09	BRIDGE APPROACH PAVEMENT CONNECTOR
515001-03	NAME PLATE FOR BRIDGES
601101-01	CONCRETE HEADWALL FOR PIPE DRAIN
630001-10	STEEL PLATE BEAM GUARDRAIL
630201-06	PCC/HMA STABILIZATION AT STEEL PLATE BEAM GUARDRAIL
630301-06	SHOULDER WIDENING FOR TYPE 1 (SPECIAL) GUARDRAIL TERMINALS
631031-11	TRAFFIC BARRIER TERMINAL, TYPE 6
635001-01	DELINEATORS
635006-03	REFLECTOR AND TERMINAL MARKER PLACEMENT
635011-02	REFLECTOR MARKER AND MOUNTING DETAILS
701001-02	OFF-RD OPERATIONS, 2L, 2W, MORE THAN 15' (4.5 m) AWAY
701006-04	OFF-RD OPERATIONS, 2L, 2W, 15' (4.5 m) TO 24" (600 mm) FROM PAVEMENT EDGE
701011-03	OFF-RD MOVING OPERATIONS, 2L, 2W, DAY ONLY
701201-04	LANE CLOSURE, 2L, 2W, DAY ONLY, FOR SPEEDS ≥ 45 MPH
701301-04	LANE CLOSURE, 2L, 2W, SHORT TIME OPERATIONS
701311-03	LANE CLOSURE, 2L, 2W, MOVING OPERATIONS - DAY ONLY
701321-13	LANE CLOSURE, 2L, 2W, BRIDGE REPAIR WITH BARRIER
701326-04	LANE CLOSURE, 2L, 2W, PAVEMENT WIDENING, FOR SPEEDS ≥ 45 MPH
701901-02	TRAFFIC CONTROL DEVICES
704001-07	TEMPORARY CONCRETE BARRIER
720001-01	SIGN PANEL MOUNTING DETAILS
720006-03	SIGN PANEL ERECTION DETAILS
720011-01	METAL POSTS FOR SIGNS, MARKERS & DELINEATORS
729001-01	APPLICATIONS OF TYPES A & B METAL POSTS (FOR SIGNS & MARKERS)
780001-03	TYPICAL PAVEMENT MARKINGS
781001-03	TYPICAL APPLICATIONS RAISED REFLECTIVE PAVEMENT MARKERS

**GENERAL NOTES**

- THE ENGINEER SHALL BE THE SOLE JUDGE CONCERNING CURING TIME FOR THE VARIOUS HMA LIFTS.
- EXCEPT AS NOTED ON THE PLANS, PAVEMENT GRADES SHOWN ARE AT THE TOP OF PAVEMENT SURFACES.
- TRIM EDGES OF EXISTING HOT MIX ASPHALT SURFACE FLUSH WITH EXISTING PAVEMENT PRIOR TO CONSTRUCTING NEW BASE COURSE.
- WHERE SECTION OR SUBSECTION MONUMENTS ARE ENCOUNTERED, THE ENGINEER SHALL BE NOTIFIED BEFORE SUCH MONUMENTS ARE REMOVED. THE CONTRACTOR SHALL PROTECT AND CAREFULLY PRESERVE ALL MONUMENTS UNTIL AN AUTHORIZED SURVEYOR OR AGENT HAS WITNESSED OR OTHERWISE REFERENCED THEIR LOCATION. THE CONTRACTOR SHALL BE RESPONSIBLE FOR HAVING AN AUTHORIZED SURVEYOR REESTABLISH ANY SECTION OR SUBSECTION MONUMENTS DESTROYED BY HIS OPERATIONS.
- THE THICKNESS OF HMA MIXTURES SHOWN ON THE PLANS IS THE NOMINAL THICKNESS. DEVIATIONS FROM THE NOMINAL THICKNESS WILL BE PERMITTED WHEN SUCH DEVIATIONS OCCUR DUE TO IRREGULARITIES IN THE EXISTING SURFACE OR BASE ON WHICH THE HMA MIXTURE IS PLACED.
- ANY REFERENCE TO A STANDARD IN THESE PLANS SHALL BE INTERPRETED TO MEAN THE EDITION AS INDICATED BY THE SUBNUMBER LISTED ON THIS SHEET OR THE COPY OF THE STANDARD INCLUDED IN THESE PLANS.
- FACTORS USED FOR ESTIMATING PLAN QUANTITIES ARE AS FOLLOWS AND SHALL NOT BE USED FOR THE BASIS OF FINAL QUANTITIES:
 

ALL HOT-MIX ASPHALT	2.016 TONS/CU YD
ALL AGGREGATE	2.05 TONS/CU YD
BITUMINOUS MATERIALS:	
ON PAVEMENT	0.09 GAL/SQ YD
INTERMEDIATE LIFTS (FOG COAT)	0.04 GAL/SQ YD
ON AGGREGATE SURFACE	0.32 GAL/SQ YD
AGGREGATE (PRIME COAT)	0.0015 TONS/SO YD
- THE CONTRACTOR SHALL BE RESPONSIBLE FOR PROTECTING UTILITY PROPERTY FROM CONSTRUCTION OPERATIONS AS OUTLINED IN ARTICLE 107.31 OF THE STANDARD SPECIFICATIONS. THE JULIE NUMBER IS 800-892-0123. A MINIMUM OF 48 HOURS ADVANCE NOTICE IS REQUIRED.
- ABANDONED UNDERGROUND UTILITIES THAT CONFLICT WITH CONSTRUCTION SHALL BE DISPOSED OF OUTSIDE THE LIMITS OF THE RIGHT OF WAY ACCORDING TO ARTICLE 202.03 OF THE STANDARD SPECIFICATIONS AND AS DIRECTED BY THE ENGINEER. THIS WORK WILL NOT BE PAID FOR SEPARATELY BUT SHALL BE INCLUDED IN THE COST OF EARTH EXCAVATION.
- ALL DISTURBED AREAS WITHIN THE CONSTRUCTION LIMITS SHALL BE FERTILIZED AND SEEDED. SEEDING SHALL BE CLASS 2A ACCORDING TO THE APPLICABLE ARTICLES OF SECTION 250 OF THE STANDARD SPECIFICATIONS. SEEDING SHALL NOT BE PERMITTED AT ANY TIME WHEN THE GROUND IS FROZEN, WET, OR IN AN UNTILLABLE CONDITION. LOCATIONS TO BE SEEDING WILL BE DETERMINED BY THE ENGINEER.
- TREES SHALL BE PRESERVED THROUGHOUT THIS SECTION AS SHOWN ON THE PLANS AND AS DIRECTED BY THE ENGINEER EXCEPT AS DESCRIBED IN NOTE 12. GENERALLY, TREES OUTSIDE THE CLEAR ZONE, AND WHICH DO NOT INTERFERE WITH CONSTRUCTION, SHALL NOT BE DISTURBED.
- ALL OBSTRUCTIONS WHICH ARE WITHIN 30' OF THE CENTERLINE OF THE ROADWAY AND ARE NOT SHIELDED BY THE PROPOSED GUARDRAIL, SHALL BE REMOVED FROM STATION 910+74 TO 916+26. TYPICAL OBSTRUCTIONS ARE HEADWALLS, FOUNDATIONS, ETC. WHICH PROJECT 4 IN. OR MORE ABOVE THE GROUNDLINE; AND TREES WHICH WILL MATURE TO A DIAMETER OF 4 IN. OR GREATER.
- THE QUANTITY OF SHORT TERM PAVEMENT MARKING SHOWN IN THE PLANS IS BASED ON ONE APPLICATION FOR THE INITIAL OPENING OF THE COMPLETED STRUCTURE TO TWO LANE TRAFFIC, AND ONE ADDITIONAL APPLICATION.
- EXISTING TRAFFIC BARRIER TERMINALS TO BE REMOVED SHALL BE PAID FOR AS GUARDRAIL REMOVAL.
- FOR STABILIZATION, ALL TYPE III BARRICADES SHALL REQUIRE A MINIMUM OF FOUR SANDBAGS PER BARRICADE.
- ALL ELEVATIONS REFER TO U.S.G.S. MEAN SEA LEVEL DATUM.
- AT ALL LOCATIONS WHERE THE PROPOSED HOT MIX ASPHALT OR CONCRETE PAVEMENT JOINS AN EXISTING HOT MIX ASPHALT OR CONCRETE PAVEMENT, A FULL DEPTH SAWED JOINT SHALL BE CONSTRUCTED.
- PRIOR TO PLACEMENT OF THE FINAL PAVEMENT MARKINGS THE RESIDENT ENGINEER SHOULD CONTACT THE BUREAU OF OPERATIONS AND ARRANGE FOR INSPECTION AND APPROVAL OF THE PAVEMENT MARKING LAYOUT.
- IN ADDITION TO THE REQUIREMENTS OF ARTICLE 107.16 THE CONTRACTOR SHALL PROTECT THE SURFACE OF ALL BRIDGE DECKS AND BRIDGE APPROACH PAVEMENTS IN A MANNER SATISFACTORY TO THE ENGINEER BEFORE ANY EQUIPMENT IS ALLOWED TO CROSS THE STRUCTURE. PROTECTION SHALL BE PROVIDED FOR ALL EQUIPMENT AS DEFINED IN ARTICLE 101.16 REGARDLESS IF TRACK MOUNTED OR WHEELED.
- RECLAIMED ASPHALT PAVEMENT (RAP) WILL NOT BE ALLOWED FOR USE AS AGGREGATE IN AGGREGATE SHOULDERS, TYPE B.

**COMMITMENTS**

- REFER TO COMMITMENT FILE FOR ANY COMMITMENTS AFTER AUGUST 16, 2013.
- DUE TO THE PRESENCE OF THE INDIANA BAT, CLEARING OF TREES SHALL BE PROHIBITED FROM APRIL 1 THROUGH SEPTEMBER 30.

**HMA MIXTURES REQUIREMENTS**

LOCATION(S):	HMA SURFACING	LEVELING BINDER	BASE COURSE	HMA SHOULDERS
MIXTURE USE(S):	HMA SURFACE CSE, MIX C, N90	LEVELING BINDER (MM), IL9.5 FG N90	HMA BINDER CSE, N90, IL-19.0	HMA SHOULDERS
AC/PC GRADE:	PG64-22	PG64-22	PG64-22	PG58-22
RAP % (MAX.): ***	SEE SPECIAL PROVISIONS	SEE SPECIAL PROVISIONS	SEE SPECIAL PROVISIONS	SEE SPECIAL PROVISIONS
DESIGN AIR VOIDS:	SEE SPECIAL PROVISIONS	SEE SPECIAL PROVISIONS	SEE SPECIAL PROVISIONS	SEE SPECIAL PROVISIONS
MIXTURE COMPOSITION: (GRADATION MIXTURE)	IL-9.5	IL-9.5	IL-19.0	HMA SHOULDERS
FRICTION AGGREGATE:	C SURFACE	C SURFACE	NONE	NONE

\*\*\* IF RAP OPTION IS SELECTED, THE ASPHALT CEMENT GRADE MAY NEED TO BE ADJUSTED AS DETERMINED BY THE ENGINEER.

STATE OF ILLINOIS  
DEPARTMENT OF TRANSPORTATION

PREPARED BY: Joe Zlanfiewicz  
DISTRICT STUDIES & PLANS ENGINEER

EXAMINED BY: Joseph E. [Signature]  
DISTRICT LAND ACQUISITION ENGINEER

EXAMINED BY: Carrie [Signature]  
DISTRICT PROGRAM DEVELOPMENT ENGINEER

EXAMINED BY: Kevin [Signature]  
DISTRICT OPERATIONS ENGINEER

EXAMINED BY: [Signature]  
DISTRICT PROJECT IMPLEMENTATION ENGINEER

EXAMINED BY: Daryl J. [Signature]  
DISTRICT CONSTRUCTION ENGINEER

EXAMINED BY: Bruce [Signature]  
DISTRICT MATERIALS ENGINEER

SUMMARY OF QUANTITIES				CONSTRUCTION CODE	
				80% FEDERAL 20% STATE ROADWAY	80% FEDERAL 20% STATE BRIDGE
CODE NO.	ITEM	UNIT	TOTAL QUANTITY	0004	0011
				ROADWAY	S. N. 076-0032
20200100	EARTH EXCAVATION	CU YD	101	101	
20400800	FURNISHED EXCAVATION	CU YD	107	107	
⊗ 25000210	SEEDING, CLASS 2A	ACRE	0.26	0.26	
⊗ 25000350	SEEDING, CLASS 7	ACRE	0.26	0.26	
⊗ 25000400	NITROGEN FERTILIZER NUTRIENT	POUND	24	24	
⊗ 25000500	PHOSPHORUS FERTILIZER NUTRIENT	POUND	24	24	
⊗ 25000600	POTASSIUM FERTILIZER NUTRIENT	POUND	24	24	
⊗ 25000700	AGRICULTURAL GROUND LIMESTONE	TON	0.6	0.6	
⊗ 25100115	MULCH, METHOD 2	ACRE	0.26	0.26	
⊗ 25100630	EROSION CONTROL BLANKET	SO YD	1269	1269	
28000250	TEMPORARY EROSION CONTROL SEEDING	POUND	60	60	
28000400	PERIMETER EROSION BARRIER	FOOT	1263	1263	
28100109	STONE RIPRAP, CLASS A5	SO YD	370		370
28200200	FILTER FABRIC	SO YD	370		370

⊗ SPECIALTY ITEM



USER NAME: HAS  
 ESCA PROJECT NO. 98812  
 PLOT SCALE: 0.3167" = 1' 0"  
 PLOT DATE: 8-2-2013

DESIGNED: JWS  
 DRAWN: HAS  
 CHECKED: RDP  
 DATE: 03/13

REVISED: -  
 REVISED: -  
 REVISED: -  
 REVISED: -

STATE OF ILLINOIS  
 DEPARTMENT OF TRANSPORTATION

SUMMARY OF QUANTITIES

SCALE: SHEET NO. 1 OF 6 SHEETS STA. TO STA.

F.A.P. RTE. 885	SECTION 112B-1	COUNTY POPE	TOTAL SHEETS 56	SHEET NO. 3
FED. ROAD DIST. NO. ILLINOIS FED. AID PROJECT AID			CONTRACT NO. 78230	

SUMMARY OF QUANTITIES				CONSTRUCTION CODE	
				80% FEDERAL 20% STATE	80% FEDERAL 20% STATE
CODE NO.	ITEM	UNIT	TOTAL QUANTITY	ROADWAY	BRIDGE
				0004	0011
				ROADWAY	S. N. 076-0032
35650500	BASE COURSE WIDENING, 10"	SQ YD	174	174	
40600100	BITUMINOUS MATERIALS (PRIME COAT)	GALLON	164	164	
40600300	AGGREGATE (PRIME COAT)	TON	2	2	
40600647	LEVELING BINDER (MACHINE METHOD), IL-9.5FG, N90	TON	46	46	
40600982	HOT-MIX ASPHALT SURFACE REMOVAL - BUTT JOINT	SQ YD	174	174	
40600990	TEMPORARY RAMP	SQ YD	30	30	
40603320	HOT-MIX ASPHALT SURFACE COURSE, MIX "C", N90	TON	106	106	
42001420	BRIDGE APPROACH PAVEMENT CONNECTOR (PCC)	SQ YD	46	46	
44000100	PAVEMENT REMOVAL	SQ YD	178	178	
48203029	HOT-MIX ASPHALT SHOULDERS, 8"	SQ YD	270	270	
50100100	REMOVAL OF EXISTING STRUCTURES	EACH	1		1
50200100	STRUCTURE EXCAVATION	CU YD	140		140
50200300	COFFERDAM EXCAVATION	CU YD	120		120
50201101	COFFERDAM (TYPE 1) (LOCATION - 1)	EACH	1		1

⊗ SPECIALTY ITEM

SUMMARY OF QUANTITIES				CONSTRUCTION CODE	
				80% FEDERAL 20% STATE ROADWAY	80% FEDERAL 20% STATE BRIDGE
CODE NO.	ITEM	UNIT	TOTAL QUANTITY	0004	0011
				ROADWAY	S. N. 076-0032
50201102	COFFERDAM (TYPE 1) (LOCATION - 2)	EACH	1		1
50300225	CONCRETE STRUCTURES	CU YD	114.7		114.7
50300255	CONCRETE SUPERSTRUCTURE	CU YD	321.7		321.7
50300260	BRIDGE DECK GROOVING	SO YD	533		533
50300300	PROTECTIVE COAT	SO YD	728	46	682
50800205	REINFORCEMENT BARS, EPOXY COATED	POUND	84220		84220
50800515	BAR SPLICERS	EACH	459		459
51201900	FURNISHING STEEL PILES HP14x89	FOOT	1860		1860
51202305	DRIVING PILES	FOOT	1860		1860
51203900	TEST PILE STEEL HP14x89	EACH	2		2
51500100	NAME PLATES	EACH	1		1
59100100	GEOCOMPOSITE WALL DRAIN	SO YD	44		44
⊗ 63000001	STEEL PLATE BEAM GUARDRAIL, TYPE A, 6 FOOT POSTS	FOOT	125	125	
⊗ 63100085	TRAFFIC BARRIER TERMINAL, TYPE 6	EACH	4	4	

⊗ SPECIALTY ITEM



GROUP TITLE - 885  
 ESCA PROJECT NO. 988.12  
 PLOT SCALE - 1/8" = 1'-0"  
 PLOT DATE - 05/20/13

DESIGNED - JMS  
 DRAWN - HAS  
 CHECKED - RDP  
 DATE - 05/13

REVISED -  
 REVISED -  
 REVISED -  
 REVISED -

STATE OF ILLINOIS  
 DEPARTMENT OF TRANSPORTATION

SUMMARY OF QUANTITIES

SCALE SHEET NO. 3 OF 6 SHEETS STA. TO STA.

F.A. P. RTE. 885	SECTION 112B-1	COUNTY POPE	TOTAL SHEETS 56	SHEET NO. 5
FED. ROAD DIST. NO. ILLINOIS FED. AID PROJECT AID			CONTRACT NO. 78230	

SUMMARY OF QUANTITIES				CONSTRUCTION CODE	
				80% FEDERAL 20% STATE ROADWAY 0004	80% FEDERAL 20% STATE BRIDGE 0011
CODE NO.	ITEM	UNIT	TOTAL QUANTITY	ROADWAY	S. N. 076-0032
⊗ 63100167	TRAFFIC BARRIER TERMINAL, TYPE I (SPECIAL) TANGENT	EACH	4	4	
63200310	GUARDRAIL REMOVAL	FOOT	459	459	
67000400	ENGINEER'S FIELD OFFICE, TYPE A	CAL MO	8	8	
67100100	MOBILIZATION	L SUM	1	1	
70100405	TRAFFIC CONTROL AND PROTECTION, STANDARD 701321	EACH	1	1	
70100450	TRAFFIC CONTROL AND PROTECTION, STANDARD 701201	L SUM	1	1	
70100500	TRAFFIC CONTROL AND PROTECTION, STANDARD 701326	L SUM	1	1	
70103815	TRAFFIC CONTROL SURVEILLANCE	CAL DA	6	6	
⊗ 70106500	TEMPORARY BRIDGE TRAFFIC SIGNALS	EACH	1	1	
70106800	CHANGEABLE MESSAGE SIGN	CAL MO	2	2	
70300100	SHORT TERM PAVEMENT MARKING	FOOT	152	152	
⊗ 70300220	TEMPORARY PAVEMENT MARKING - LINE 4"	FOOT	1525	1525	
70301000	WORK ZONE PAVEMENT MARKING REMOVAL	SO FT	561	561	
70400100	TEMPORARY CONCRETE BARRIER	FOOT	425	425	

⊗ SPECIALTY ITEM



JEFF NAME: JMS  
 ESCA PROJECT NO. 989.12  
 PLOT SCALE: 0.1667" = 1'-0"  
 PLOT DATE: 03/13/2013

DESIGNED: JMS  
 DRAWN: HAS  
 CHECKED: RDP  
 DATE: 03/13

REVISED: -  
 REVISED: -  
 REVISED: -  
 REVISED: -

STATE OF ILLINOIS  
 DEPARTMENT OF TRANSPORTATION

SUMMARY OF QUANTITIES

SCALE: SHEET NO. 4 OF 6 SHEETS STA. TO STA.

F.A.P. RTE. 885	SECTION 112B-1	COUNTY POPE	TOTAL SHEETS 56	SHEET NO. 6
CONTRACT NO. 78230			ILLINOIS FED. AID PROJECT AID	

SUMMARY OF QUANTITIES				CONSTRUCTION CODE	
				80% FEDERAL 20% STATE ROADWAY	80% FEDERAL 20% STATE BRIDGE
CODE NO.	ITEM	UNIT	TOTAL QUANTITY	0004	0011
				ROADWAY	S. N. 076-0032
70400200	RELOCATE TEMPORARY CONCRETE BARRIER	FOOT	400	400	
70600250	IMPACT ATTENUATORS, TEMPORARY (NON-REDIRECTIVE) TEST LEVEL 3	EACH	2	2	
70600350	IMPACT ATTENUATORS, RELOCATE (NON-REDIRECTIVE), TEST LEVEL 3	EACH	2	2	
⊗ 78001110	PAINT PAVEMENT MARKING - LINE 4"	FOOT	1525	1525	
⊗ 78100100	RAISED REFLECTIVE PAVEMENT MARKER	EACH	6	6	
⊗ 78100105	RAISED REFLECTIVE PAVEMENT MARKER (BRIDGE)	EACH	2	2	
78200410	GUARDRAIL MARKERS, TYPE A	EACH	4	4	
78200520	BARRIER WALL MARKERS, TYPE B	EACH	8	8	
⊗ 78201000	TERMINAL MARKER - DIRECT APPLIED	EACH	4	4	
78300100	PAVEMENT MARKING REMOVAL	SQ FT	508	508	
78300200	RAISED REFLECTIVE PAVEMENT MARKER REMOVAL	EACH	8	8	
86200300	UNINTERRUPTABLE POWER SUPPLY, EXTENDED	EACH	1	1	
X5860110	GRANULAR BACKFILL FOR STRUCTURES	CU YD	66		66
Z0018005	DRAINAGE SCUPPERS, DS-12 M 10"	EACH	4		4

⊗ SPECIALTY ITEM



USER NAME: HAS  
 ESCA PROJECT NO: 98812  
 PLOT SCALE: 0.1667 1/8" IN.  
 PLOT DATE: 03/13/13

DESIGNED: JMS  
 DRAWN: HAS  
 CHECKED: RDP  
 DATE: 03/13

REVISED:  
 REVISED:  
 REVISED:  
 REVISED:

STATE OF ILLINOIS  
 DEPARTMENT OF TRANSPORTATION

SUMMARY OF QUANTITIES

SCALE: SHEET NO. 5 OF 6 SHEETS STA. TO STA.

F.A.P. RTE. 885	SECTION 112B-1	COUNTY POPE	TOTAL SHEETS 56	SHEET NO. 7
FED. ROAD DIST. NO.		ILLINOIS FED. AID PROJECT AID CONTRACT NO. 78230		





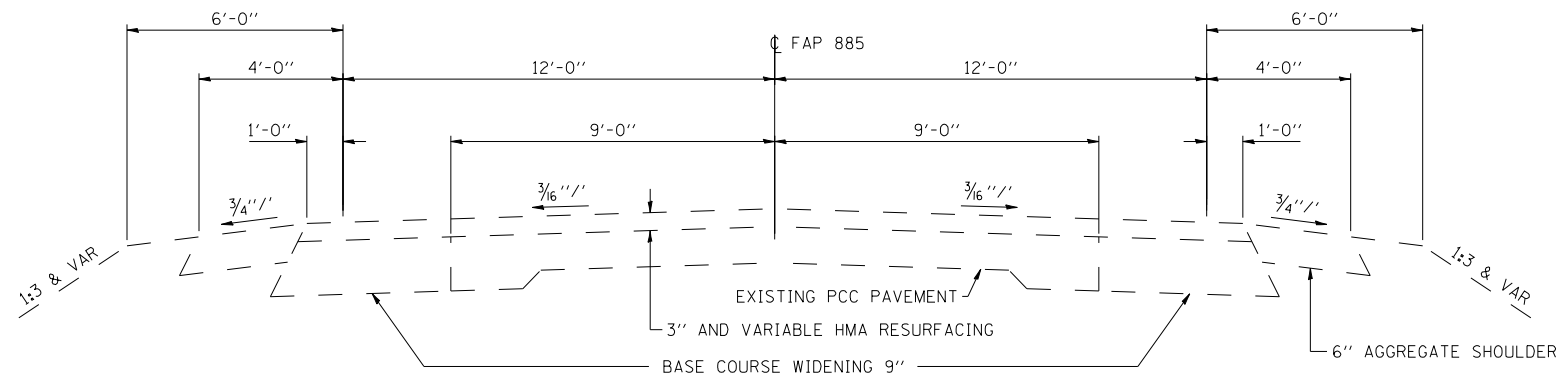

**EXISTING TYPICAL SECTION  
STA 910+74 TO 912+92.08  
STA 914+07.92 TO 916+26**

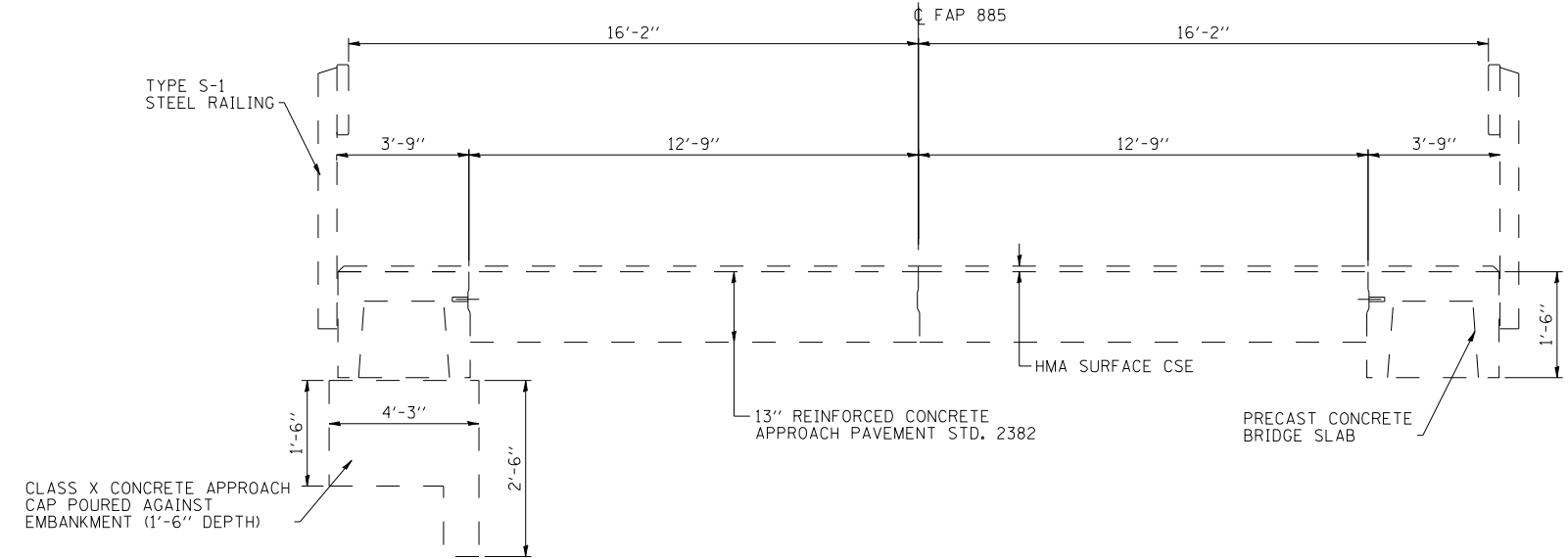

**HALF SECTION THRU  
END OF APPROACH PAVEMENT  
AND PRECAST CONCRETE  
BRIDGE SLAB**

**EXISTING TYPICAL SECTION  
STA 912+92.08 TO 913+12.00  
STA 913+88.00 TO STA 914+07.92**

**HALF SECTION THRU  
MID-SPAN OF APPROACH  
PAVEMENT AND PRECAST  
CONCRETE BRIDGE SLAB**

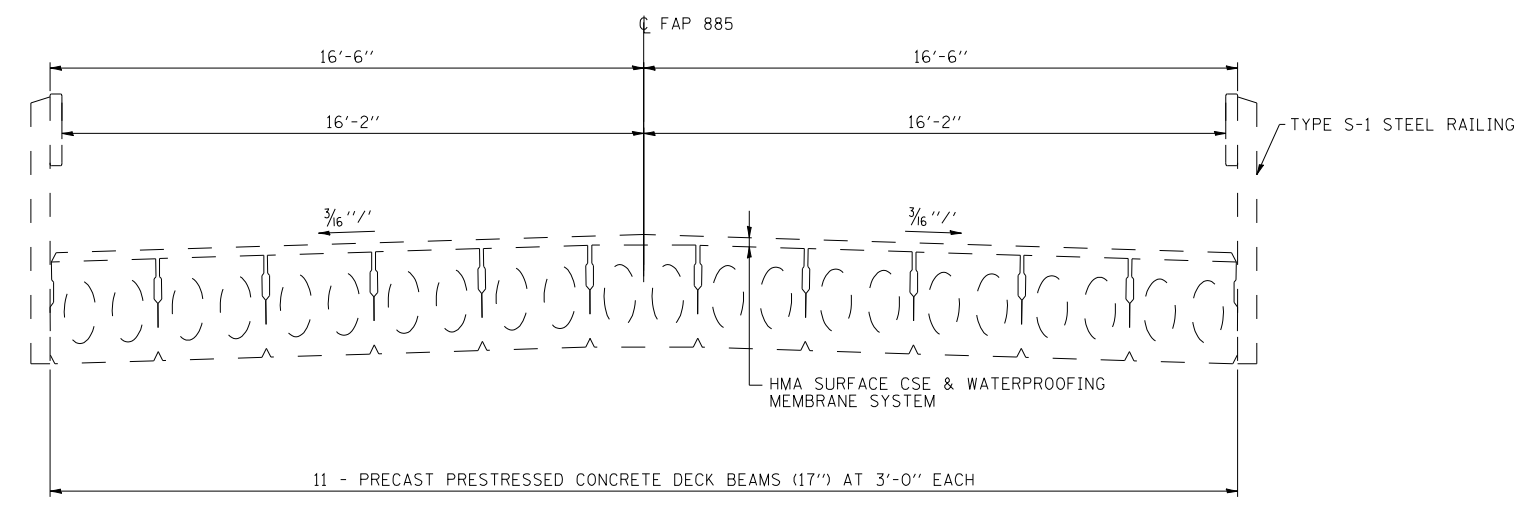

**EXISTING TYPICAL SECTION  
CENTERLINE STRUCTURE STA 913+50**

PRINT DRIVER = L:\05-EB\0411...  
 SCALE NAME = PLOT...  
 FILE NAME = 07022013...



USER NAME = has	DESIGNED - JMS	REVISED -
ESCA PROJECT NO. 988.12	DRAWN - HAS	REVISED -
PLOT SCALE = 0.1667' / IN.	CHECKED - RDP	REVISED -
PLOT DATE = 8/2/2013 11:28:34 AM	DATE - 03/13	REVISED -

**STATE OF ILLINOIS  
DEPARTMENT OF TRANSPORTATION**

**TYPICAL SECTIONS**

SCALE: SHEET NO. 1 OF 4 SHEETS STA. TO STA.

F.A.P. RTE.	SECTION	COUNTY	TOTAL SHEETS	SHEET NO.
885	112B-1	POPE	56	9
FED. ROAD DIST. NO. ILLINOIS FED. AID PROJECT			CONTRACT NO. 78230	

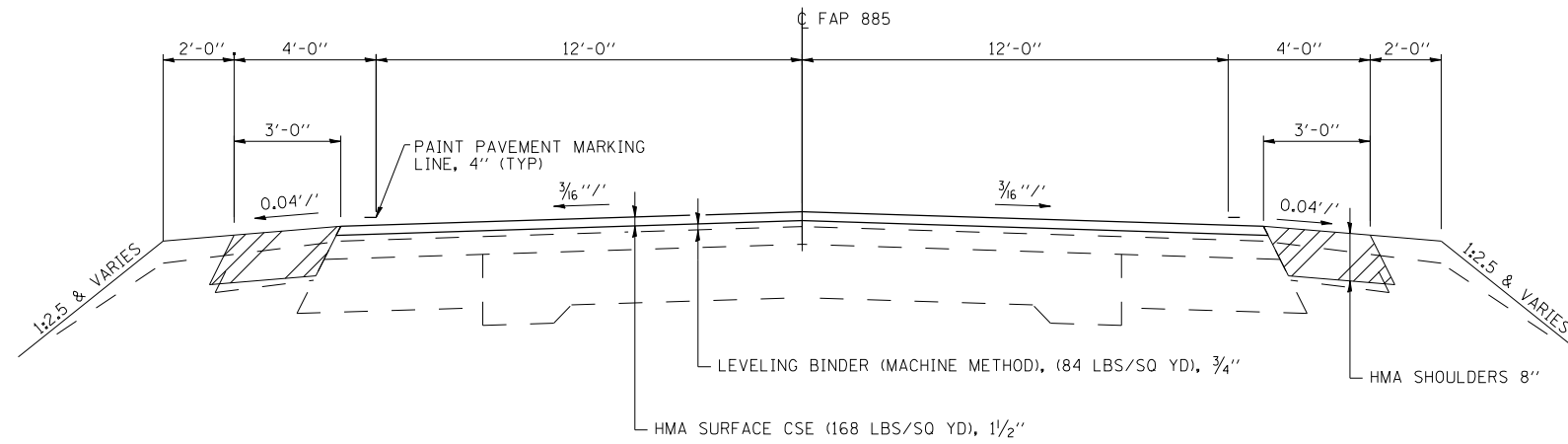

**PROPOSED TYPICAL SECTION**  
**STA 910+74 TO 911+19**  
**STA 915+81 TO 916+26**

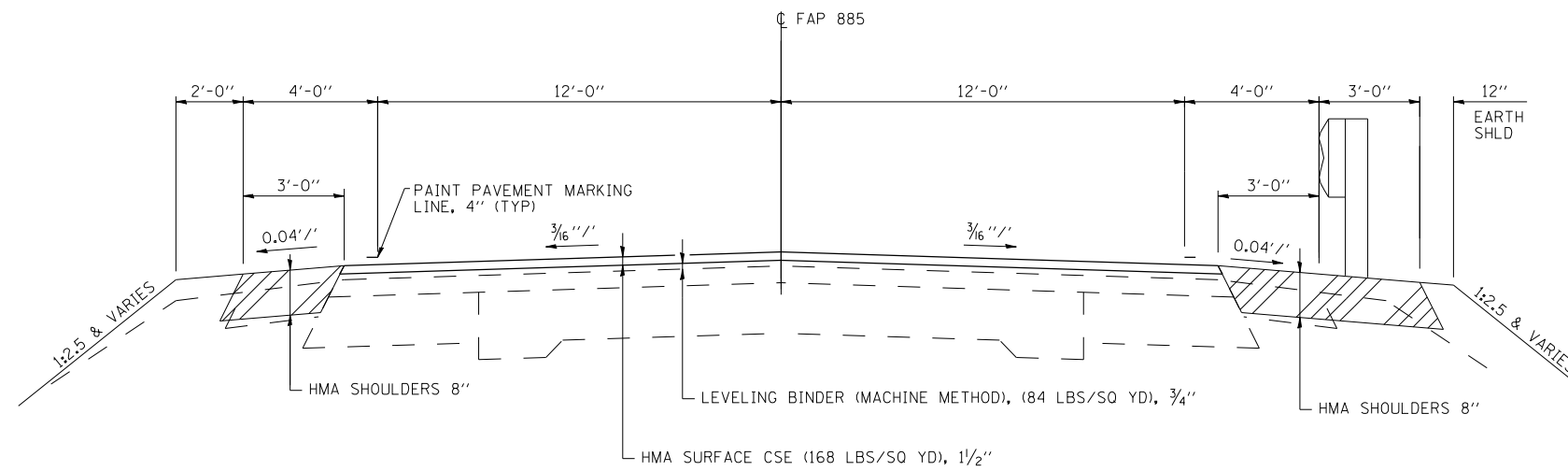

**PROPOSED TYPICAL SECTION**  
**STA 911+19 TO 911+50**

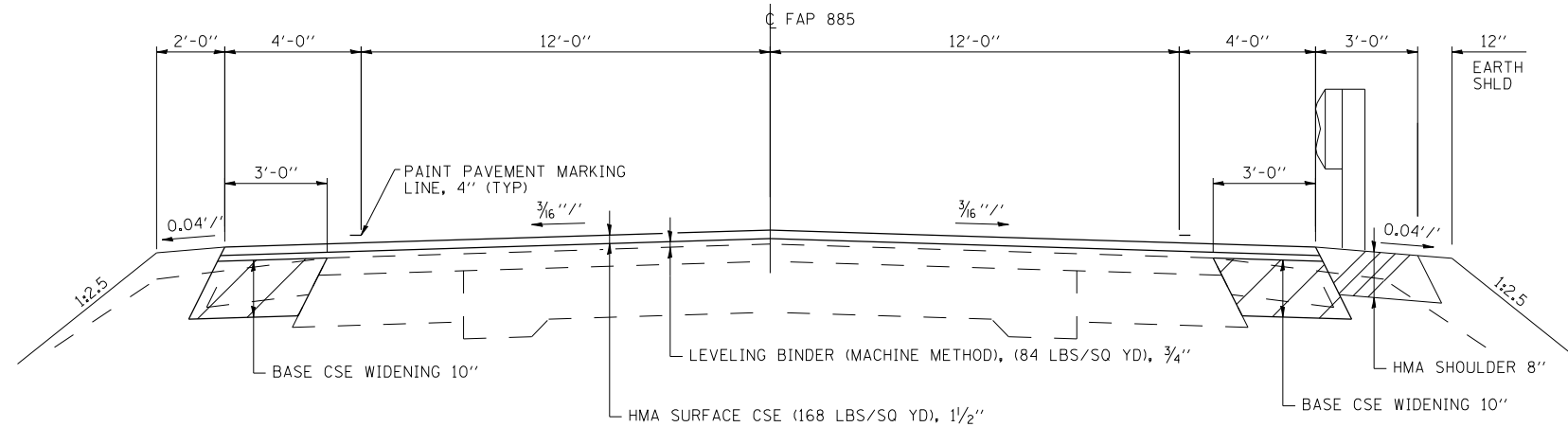

**PROPOSED TYPICAL SECTION**  
**STA 911+50 TO 911+81**

PRINT DRIVER = L:\D-ES\B\A\112230-112230-112230.dwg  
 SCALE NAME = 1:2.5  
 FILE NAME = 112230-112230-112230.dwg



USER NAME = has	DESIGNED - JMS	REVISED -
ESCA PROJECT NO. 988.12	DRAWN - HAS	REVISED -
PLOT SCALE = 0.1667' / IN.	CHECKED - RDP	REVISED -
PLOT DATE = 8/2/2013 11:28:52 AM	DATE - 03/13	REVISED -

**STATE OF ILLINOIS**  
**DEPARTMENT OF TRANSPORTATION**

**TYPICAL SECTIONS**

SCALE: SHEET NO. 2 OF 4 SHEETS STA. TO STA.

F.A.P. RTE.	SECTION	COUNTY	TOTAL SHEETS	SHEET NO.
885	112B-1	POPE	56	10
FED. ROAD DIST. NO. ILLINOIS FED. AID PROJECT			CONTRACT NO. 78230	

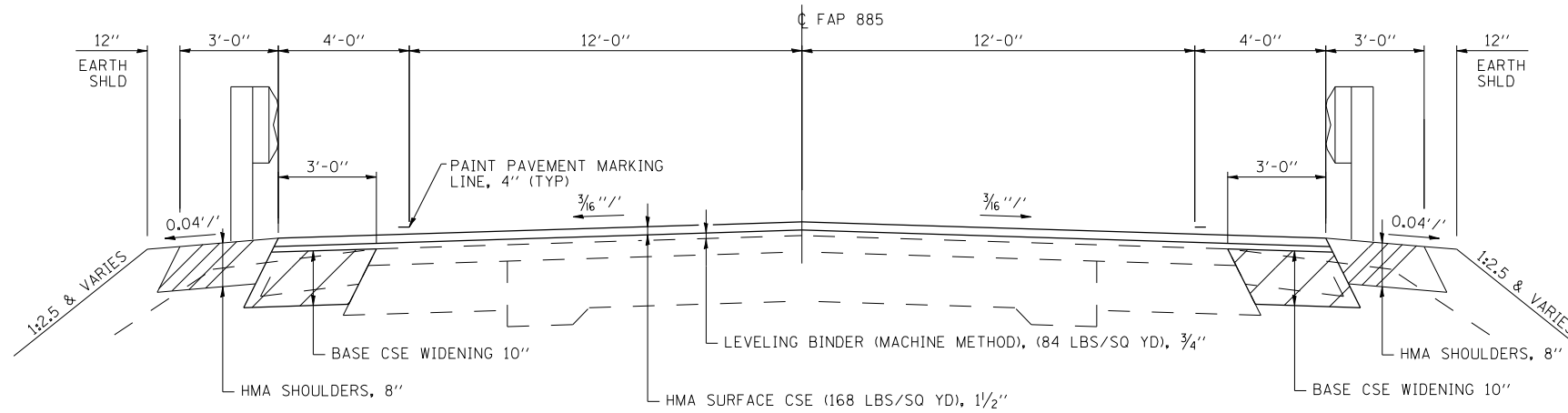

**PROPOSED TYPICAL SECTION**  
**STA 911+81 TO 912+70.50**  
**STA 914+29.50 TO 915+18**

NOTE: BRIDGE APPROACH PAVEMENT CONNECTOR (PCC)  
 STA 912+64.50 TO STA 912+70.50  
 STA 914+29.50 TO STA 914+35.50

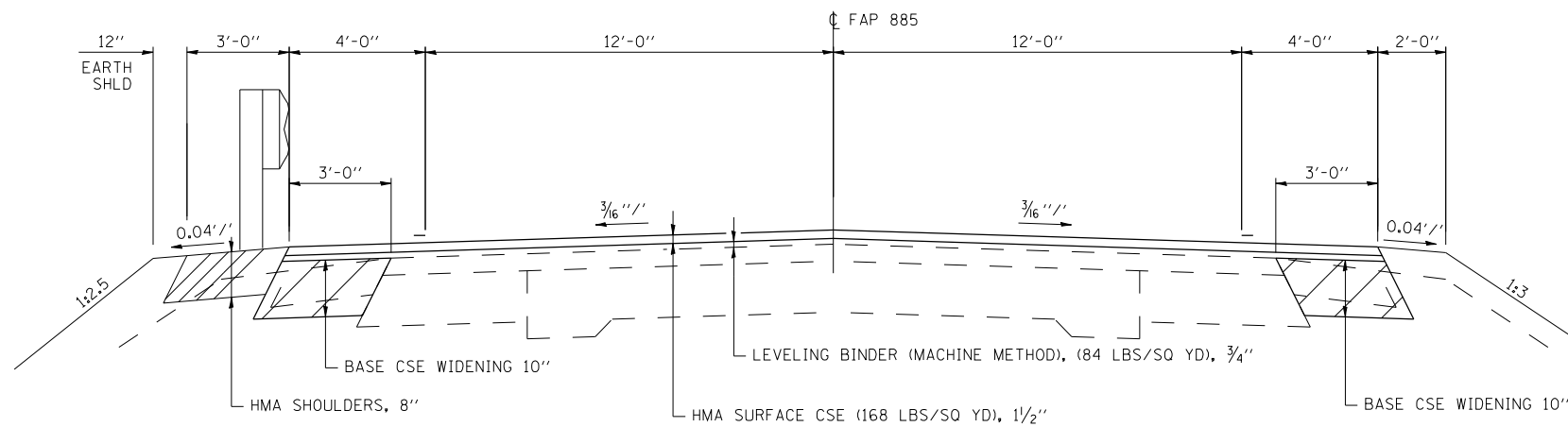

**PROPOSED TYPICAL SECTION**  
**STA 915+18 TO 915+50**

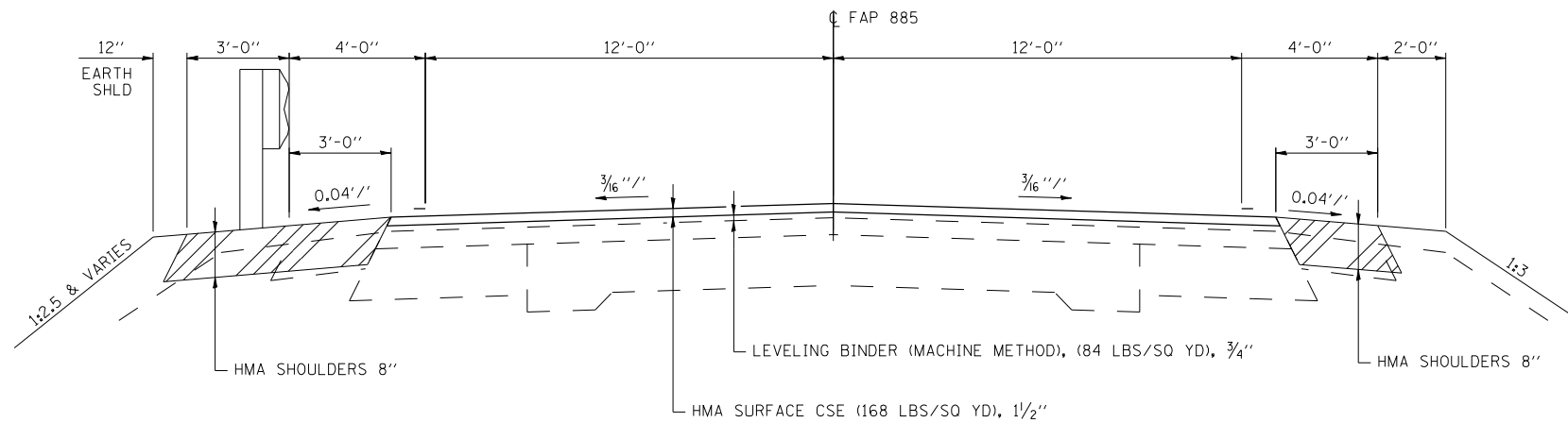

**PROPOSED TYPICAL SECTION**  
**STA 915+50 TO 915+81**

PRINT DRIVER = LUD-ER-BAU  
 SCALE NAME = PLOT  
 FILE NAME = D:\2013\8-2-2013\112911.dwg



USER NAME = has	DESIGNED - JMS	REVISED -
ESCA PROJECT NO. 988.12	DRAWN - HAS	REVISED -
PLOT SCALE = 0.1667' / IN.	CHECKED - RDP	REVISED -
PLOT DATE = 8/2/2013 11:29:11 AM	DATE - 03/13	REVISED -

**STATE OF ILLINOIS**  
**DEPARTMENT OF TRANSPORTATION**

**TYPICAL SECTIONS**

SCALE: SHEET NO. 3 OF 4 SHEETS STA. TO STA.

F.A.P. RTE.	SECTION	COUNTY	TOTAL SHEETS	SHEET NO.
885	112B-1	POPE	56	11
FED. ROAD DIST. NO. ILLINOIS FED. AID PROJECT			CONTRACT NO. 78230	

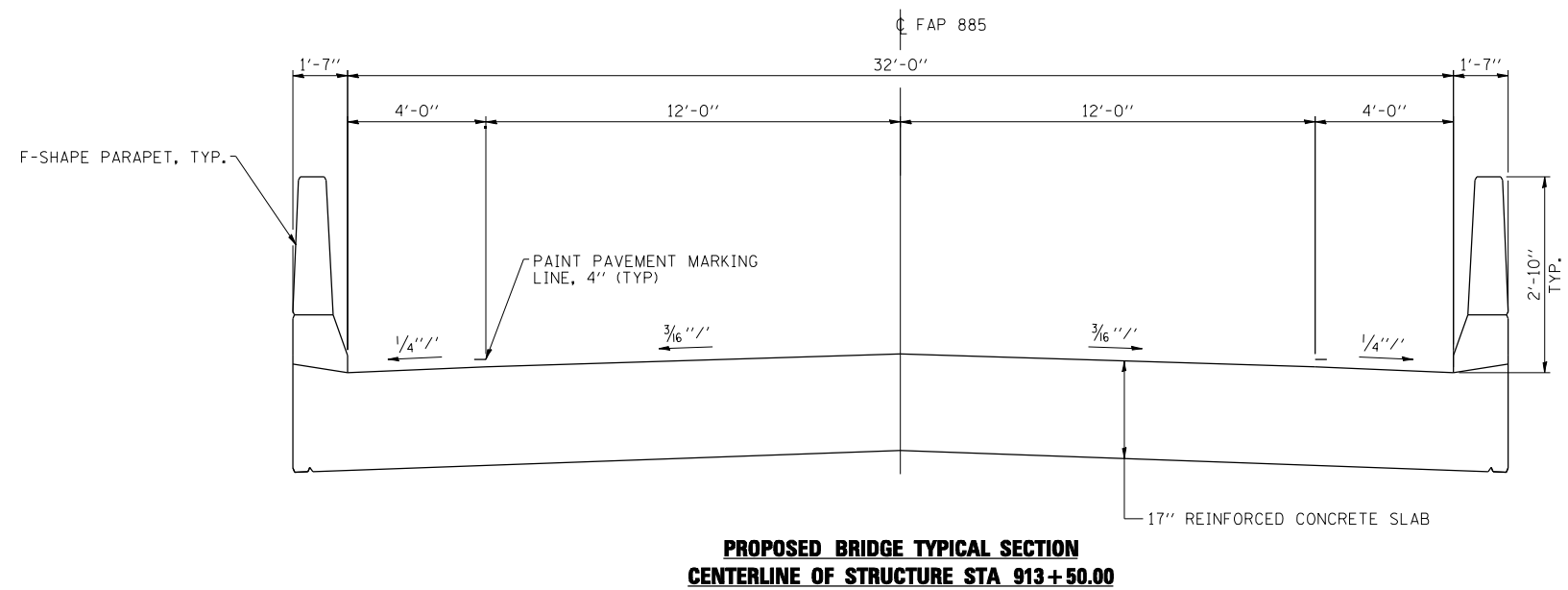
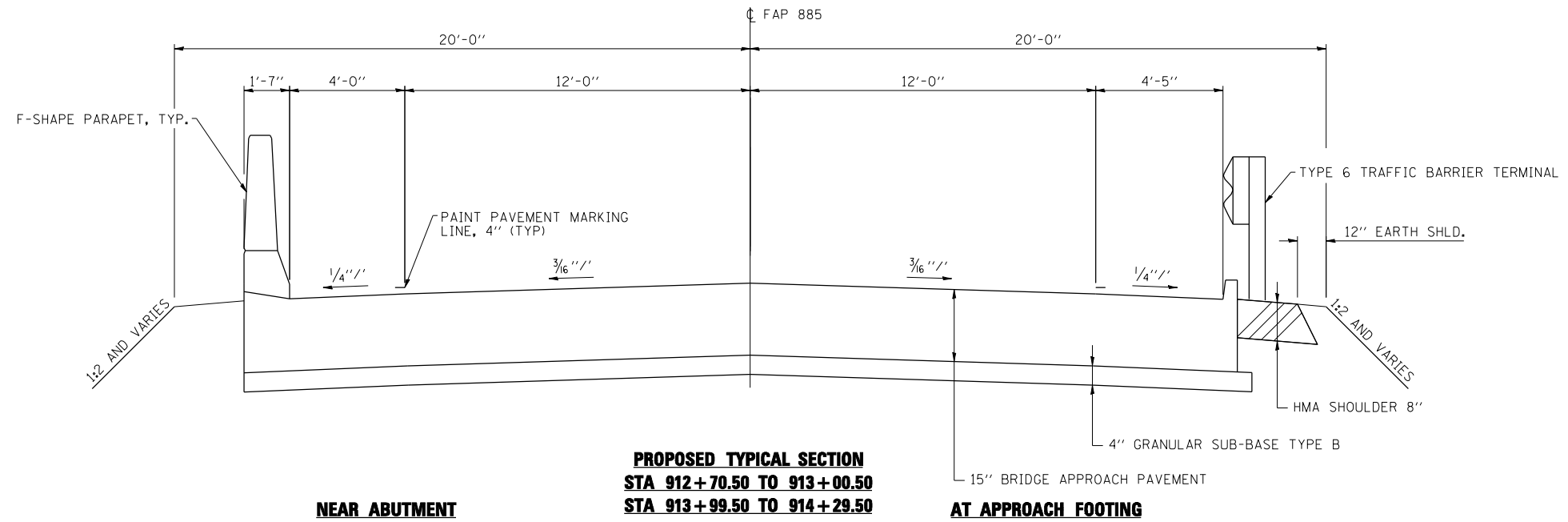

PRINT DRIVER = LUD-ER-BAR-01  
 SCALE NAME = PLOT  
 FILE NAME = D:\2013\8-2-2013\112B-1.dwg



USER NAME = has	DESIGNED - JMS	REVISED -
ESCA PROJECT NO. 988.12	DRAWN - HAS	REVISED -
PLOT SCALE = 0.1667' / IN.	CHECKED - RDP	REVISED -
PLOT DATE = 8/2/2013 11:29:31 AM	DATE - 03/13	REVISED -

**STATE OF ILLINOIS**  
**DEPARTMENT OF TRANSPORTATION**

<b>TYPICAL SECTIONS</b>	
SCALE:	SHEET NO. 4 OF 4 SHEETS STA. TO STA.

F.A.P. RTE.	SECTION	COUNTY	TOTAL SHEETS	SHEET NO.
885	112B-1	POPE	56	12
FED. ROAD DIST. NO. ILLINOIS FED. AID PROJECT			CONTRACT NO. 78230	

EARTHWORK SCHEDULE						
LOCATION	EARTH EXCAVATION	SUITABLE EARTH EXCAVATION ADJUSTED FOR SHRINKAGE	RIPRAP EXCAVATION MATERIAL	SUITABLE RIPRAP EXC. MATERIAL ADJUSTED FOR SHRINKAGE	EMBANKMENT (NOT A PAY ITEM)	EARTHWORK BALANCE WASTE (+) OR SHORTAGE (-)
	CU YD	CU YD	CU YD	CU YD	CU YD	CU YD
RT STA 910+00 TO 913+00	20	15			29	-14
LT STA 910+00 TO 913+00	15	11			76	-65
STA 913+00 TO 914+00	35	26	325	SEE NOTE 4		26
RT STA 914+00 TO 917+00	20	15			14	1
LT STA 914+00 TO 917+00	11	8			63	-55
TOTALS	101	75	325		182	-107

**NOTES:**

- EXCAVATION USED AS EMBANKMENT = (SUITABLE EARTH EXCAVATION)\*0.75
- RIPRAP EXCAVATION IS NOT A PAY ITEM AND IT IS INCLUDED IN THE COST OF STONE RIPRAP CLASS A5.
- THE EARTHWORK SCHEDULE DOES NOT REFLECT THE EARTHWORK AND EARTHWORK BALANCE FOR THE VARIOUS STAGES.
- THE EARTHWORK SCHEDULE HAS ASSUMED THE RIPRAP EXCAVATION MAY NOT BE SUITABLE FOR USE AS EMBANKMENT

PAVEMENT MARKING SCHEDULE				
LOCATION	DESCRIPTION	SHORT-TERM PAVEMENT MARKING	PAINT PAVEMENT MARKING - LINE	TEMP PAVEMENT MARKING - LINE
		①	4"	4"
		FOOT	FOOT	FOOT
CL STA 909+80 TO 917+23	YELLOW SKIP-DASH	152	190	190
RT STA 909+93 TO 916+63	WHITE EDGE		670	670
LT STA 910+40 TO 917+05	WHITE EDGE		665	665
TOTALS		152	1525	1525

① INCLUDES 2 APPLICATIONS

EROSION CONTROL SCHEDULE			
LOCATION	TEMPORARY EROSION CONTROL SEEDING (2 APPLICATIONS)	PERIMETER EROSION BARRIER	EROSION CONTROL BLANKET
	POUND	FOOT	SQ YD
NW QUADRANT		318	367
NE QUADRANT		312	321
SW QUADRANT		316	268
SE QUADRANT		317	313
JOBSITE	60		
TOTALS	60	1263	1269

RAISED REFLECTIVE PAVEMENT MARKER SCHEDULE			
LOCATION	RRPM	RRPM (BRIDGE)	RRPM REMOVAL
	EACH	EACH	EACH
STA 910+74 TO 916+26	6	2	8
TOTALS	6	2	8

WORK ZONE AND PAVEMENT MARKING REMOVAL SCHEDULE			
LOCATION	PAVEMENT MARKING DESCRIPTION	WORK ZONE PAVEMENT MARKING REMOVAL	PAVEMENT MARKING REMOVAL
		SQ FT	SQ FT
CL STA 909+80 TO 917+23	YELLOW SKIP-DASH		62
RT STA 909+83 TO 916+63	WHITE EDGE		224
LT STA 910+40 TO 917+05	WHITE EDGE		222
CL STA 909+80 TO 917+23	YELLOW SKIP-DASH	51 ①	
CL STA 909+80 TO 917+23	YELLOW SKIP-DASH	64 ②	
RT STA 909+93 TO 916+63	WHITE EDGE	224 ②	
LT STA 910+40 TO 917+05	WHITE EDGE	222 ②	
TOTALS		561	508

- ① REMOVAL OF SHORT-TERM PAVEMENT MARKING  
 ② REMOVAL OF TEMP PAVEMENT MARKING - LINE

SEEDING SCHEDULE							
LOCATION	SEEDING, CLASS 2A	SEEDING, CLASS 7	NITROGEN FERTILIZER NUTRIENT	PHOSPHORUS FERTILIZER NUTRIENT	POTASSIUM FERTILIZER NUTRIENT	AGRICULTURAL GROUND LIMESTONE	MULCH, METHOD 2
	ACRE	ACRE	POUND	POUND	POUND	TON	ACRE
NW QUADRANT	0.07	0.07	6	6	6	0.15	0.07
NE QUADRANT	0.07	0.07	6	6	6	0.15	0.07
SW QUADRANT	0.06	0.06	6	6	6	0.15	0.06
SE QUADRANT	0.06	0.06	6	6	6	0.15	0.06
TOTALS	0.26	0.26	24	24	24	0.6	0.26

BASE COURSE WIDENING 10" SCHEDULE	
LOCATION	BASE COURSE WIDENING, 10"
	SO YD
LT STA 911+50 TO 912+92	48
LT STA 914+08 TO 915+50	48
RT STA 911+50 TO 912+64.50	39
RT STA 914+35.50 TO 915+50	39
TOTAL	174

HMA SHOULDERS 8" SCHEDULE	
LOCATION	HMA SHOULDERS, 8"
	SO YD
LT STA 910+74 TO 912+85.50	57
LT STA 914+14.50 TO 916+26	78
RT STA 910+74 TO 912+85.50	78
RT STA 914+14.50 TO 916+26	57
TOTAL	270

PAVING SCHEDULE					
LOCATION	LEVELING BINDER (MM), IL-9.5 FG, N90	HMA SURFACE COURSE, MIX "C", N90	BITUMINOUS MATERIALS (PRIME COAT)	AGGREGATE (PRIME COAT)	TEMPORARY RAMP
	TON	TON	GALLON	TON	SQ YD
STA 911+04 TO 912+64.50	23				
STA 914+35.50 TO 915+96	23				
STA 910+74 TO 912+64.50		53	82	1	
STA 914+35.50 TO 916+26		53	82	1	
STA 910+74 TO 910+79					15
STA 916+21 TO 916+26					15
TOTALS	46	106	164	2	30

REMOVAL SCHEDULE		
LOCATION	PAVEMENT REMOVAL	HMA SURFACE REMOVAL - BUTT JOINT
	SO YD	SO YD
STA 910+74 TO 911+04		87
STA 915+96 TO 916+26		87
STA 912+64.50 TO 912+92	80	
STA 914+08 TO 914+35.50	80	
LT STA 912+64.50 TO 912+92	9	
LT STA 914+08 TO 914+35.50	9	
TOTALS	178	174

GUARDRAIL SCHEDULE						
LOCATION	SPBGR, TYPE A, 6 FOOT POSTS	TRAFFIC BARRIER TERMINAL		GUARDRAIL MARKERS, TYPE A	BARRIER WALL MARKERS, TYPE B	TERMINAL MARKER, DIRECT APPLIED
		TYPE 6	TYPE 1 (SPECIAL) TANGENT			
		FOOT	EACH			
NW QUADRANT		1	1			1
NE QUADRANT	62.5	1	1			1
SE QUADRANT		1	1			1
SW QUADRANT	62.5	1	1			1
LT STA 912+50 TO 914+90				2	4	
RT STA 912+10 TO 914+50				2	4	
TOTALS	125	4	4	4	8	4

GUARDRAIL REMOVAL SCHEDULE	
LOCATION	FOOT
STRUCTURE NO. 076-0032 NW	39
STRUCTURE NO. 076-0032 NE	190
STRUCTURE NO. 076-0032 SW	190
STRUCTURE NO. 076-0032 SE	40
TOTAL	459

ESCA CONSULTING ENGINEERS, INC.  
 1000 N. WILSON AVENUE, SUITE 200  
 DEERFIELD, ILLINOIS 60015-4100  
 TEL: 847.938.8800 FAX: 847.938.8801  
 WWW.ESCA-ILL.COM



USER NAME = h01st00dw  
 ESCA PROJECT NO. 988.12  
 PLOT SCALE = 8.1687' / 1" IN.  
 PLOT DATE = 8/15/2013 9:15:20 AM

DESIGNED - JMS  
 DRAWN - HAS  
 CHECKED - RDP  
 DATE - 03/13

REVISED -  
 REVISED -  
 REVISED -  
 REVISED -

STATE OF ILLINOIS  
 DEPARTMENT OF TRANSPORTATION

SCHEDULE OF QUANTITIES

SCALE SHEET NO. 1 OF 1 SHEETS STA. TO STA.

F.A.P. RTE. 885	SECTION 112B-1	COUNTY POPE	TOTAL SHEETS 56	SHEET NO. 13
CONTRACT NO. 78230			ILLINOIS FED. AID PROJECT AID	

PLAN	SURVEYED	BY	DATE
NOTE BOOK NO.	PLOTTED		
	CHECKED		
	AT		
	FILE NAME		

PROFILE	SURVEYED	BY	DATE
NOTE BOOK NO.	GRADES CHECKED		
	STRUCTURE		
	NOT AT THIS CHFD		

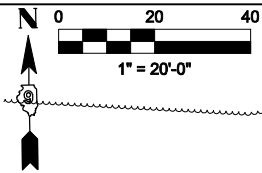

905+00      906      907      908      909      910+00

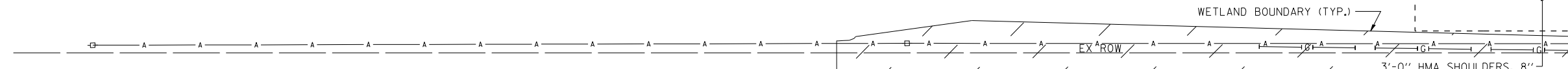

**LEGEND**

- HMA SURFACE REMOVAL
- HMA SHOULDERS 8"
- HMA BASE CSE WIDENING
- BR APPR PVMT CON (PCC)
- WETLAND AREA

NOTE: WETLAND SITE DISTURBANCE INSIDE OF CONSTRUCTION LIMITS TO BE MINIMAL. WETLAND SITES OUTSIDE OF CONSTRUCTION LIMITS ARE NOT TO BE DISTURBED.

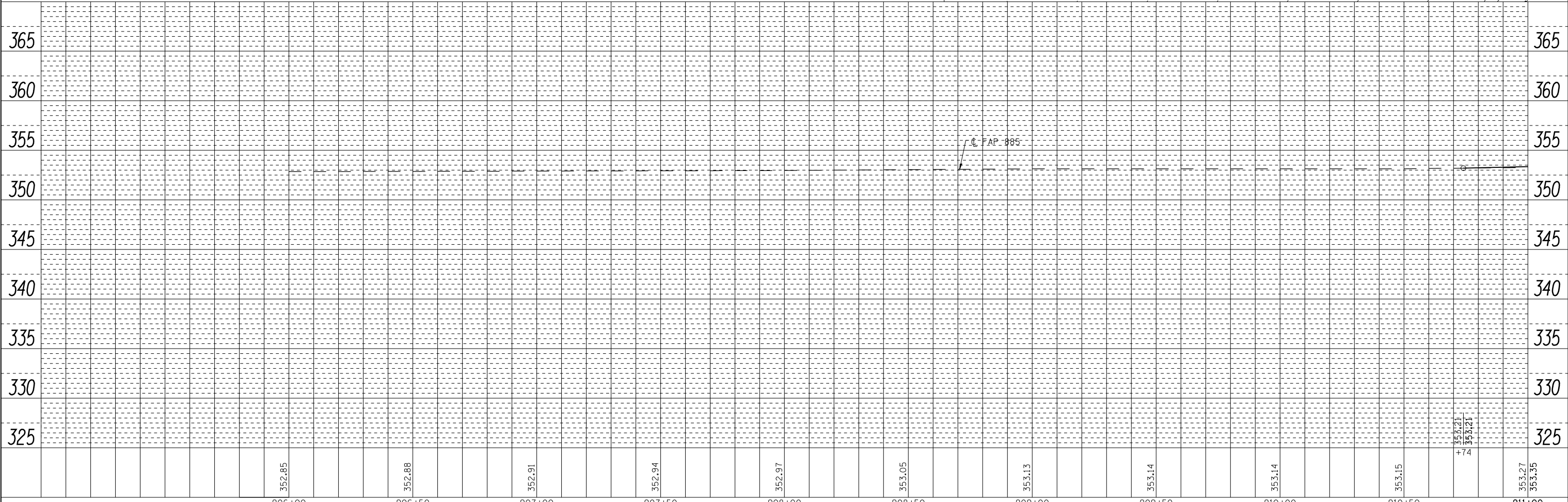

906+00      906+50      907+00      907+50      908+00      908+50      909+00      909+50      910+00      910+50      911+00



USER NAME = has	DESIGNED - JMS	REVISED -
ESCA PROJECT NO. 988.07	DRAWN - RJT/HAS	REVISED -
SCALEs: (HORIZ) 1"=20' (VERT) 1"=5'	CHECKED - RDP	REVISED -
PLOT DATE = 8/2/2013 11:30:41 AM	DATE - 03/13	REVISED -

**STATE OF ILLINOIS  
DEPARTMENT OF TRANSPORTATION**

**FAP 885 (IL 146) PLAN & PROFILE**

SCALE: AS SHOWN    SHEET NO. 1 OF 3 SHEETS    STA. 910+74 TO STA. 911+00

F.A.P. RTE. 885	SECTION 112B-1	COUNTY POPE	TOTAL SHEETS 56	SHEET NO. 14
CONTRACT NO. 78230			FED. ROAD DIST. NO. 9 ILLINOIS FED. AID PROJECT AID	

MATCH LINE STA. 911+00

PLAN	SURVEYED	BY	DATE
	NOTED		
	PLOTTED		
	CHECKED		
	AT		
	FILE NAME		
	NO.		

PROFILE	SURVEYED	BY	DATE
	GRADES		
	CHECKED		
	AT		
	FILE NAME		
	NO.		

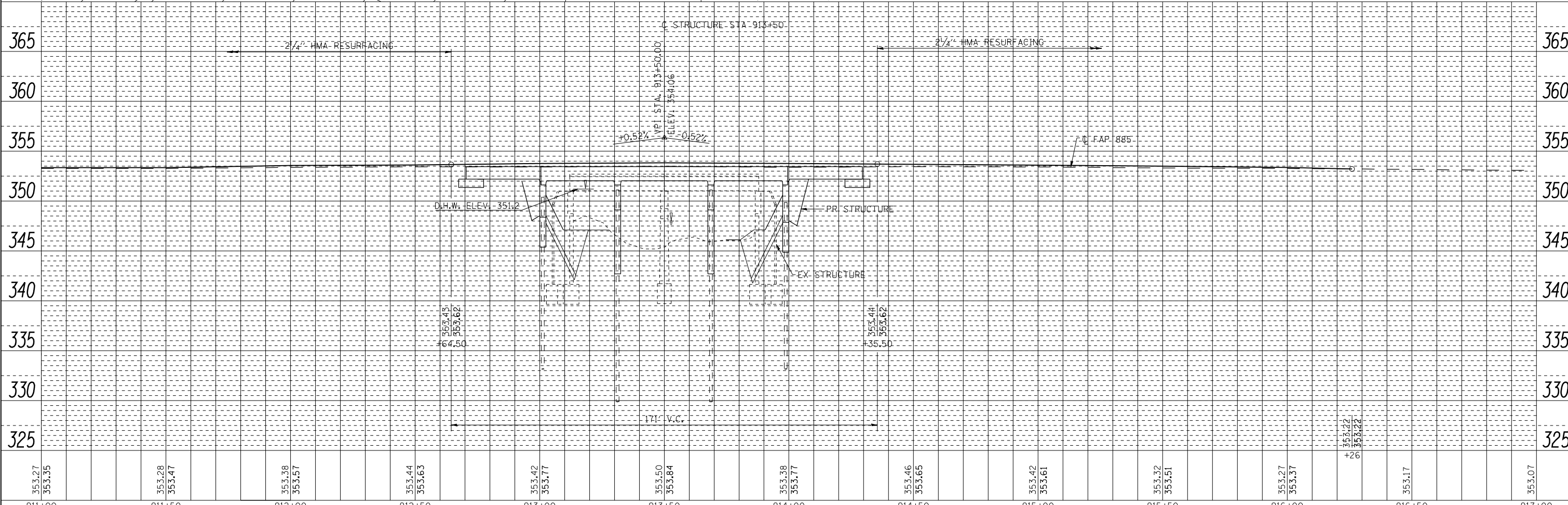
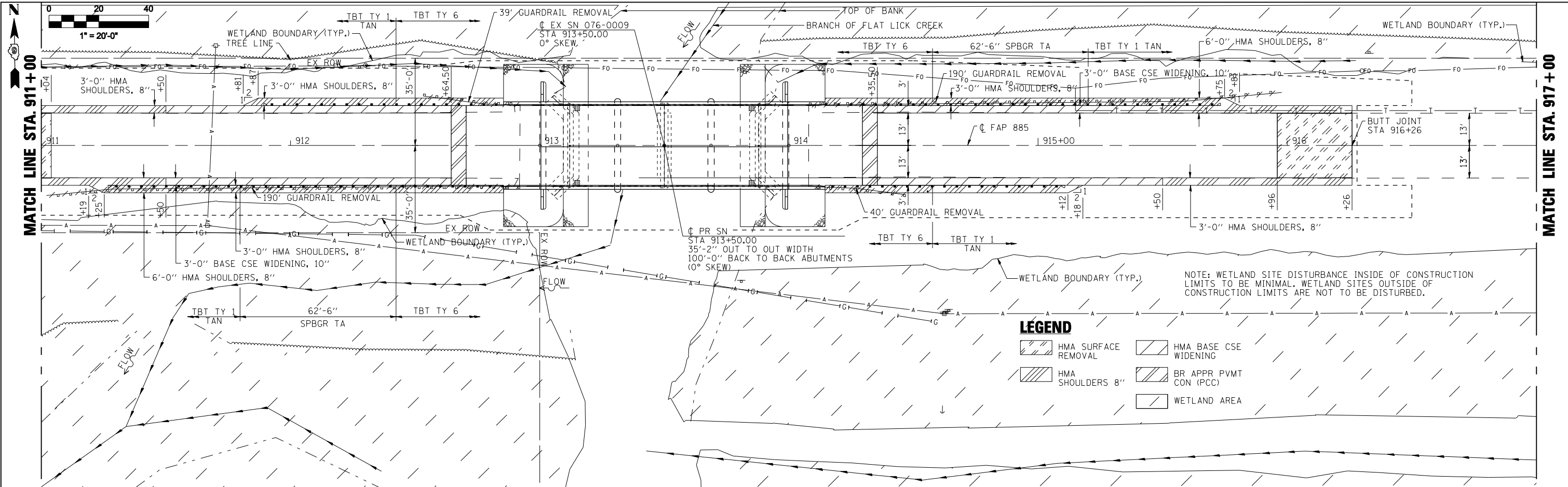

USER NAME = has	DESIGNED - JMS	REVISED -
ESCA PROJECT NO. 988.07	DRAWN - RJT/HAS	REVISED -
SCALEs: (HORIZ) 1"=20' (VERT) 1"=5'	CHECKED - RDP	REVISED -
PLOT DATE = 8/2/2013 11:31:00 AM	DATE - 03/13	REVISED -

**STATE OF ILLINOIS  
DEPARTMENT OF TRANSPORTATION**

**FAP 885 (IL 146) PLAN & PROFILE**

SCALE: AS SHOWN SHEET NO. 2 OF 3 SHEETS STA. 911+00 TO STA. 917+00

F.A.P. RTE. 885	SECTION 112B-1	COUNTY POPE	TOTAL SHEETS 56	SHEET NO. 15
CONTRACT NO. 78230				
FED. ROAD DIST. NO. 9 ILLINOIS FED. AID PROJECT AID				

PRINT DRIVER = LPOLE@ESCA.COM  
 PLOT MAKE = PLOT  
 FILE NAME = D:\988.07\988.07.dwg

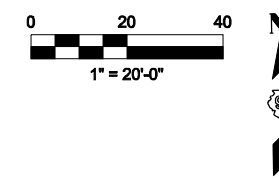

MATCH LINE STA. 917+00

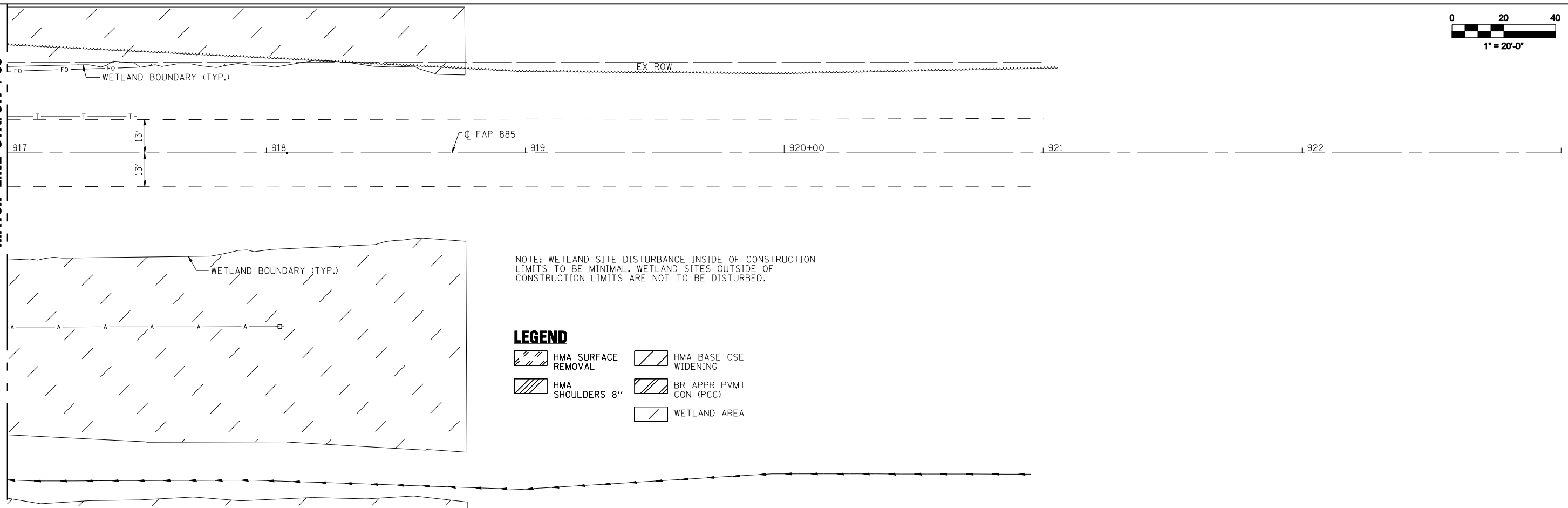

NOTE: WETLAND SITE DISTURBANCE INSIDE OF CONSTRUCTION LIMITS TO BE MINIMAL. WETLAND SITES OUTSIDE OF CONSTRUCTION LIMITS ARE NOT TO BE DISTURBED.

**LEGEND**

- HMA SURFACE REMOVAL
- HMA BASE CSE WIDENING
- HMA SHOULDERS 8"
- BR APPR PVMT CON (PCC)
- WETLAND AREA

PLAN	SURVEYED	CHECKED	DATE
NOTE BOOK NO.	AT	BY	

PROFILE	SURVEYED	CHECKED	DATE
NOTE BOOK NO.	GRADES	BY	
	STRUCTURE		

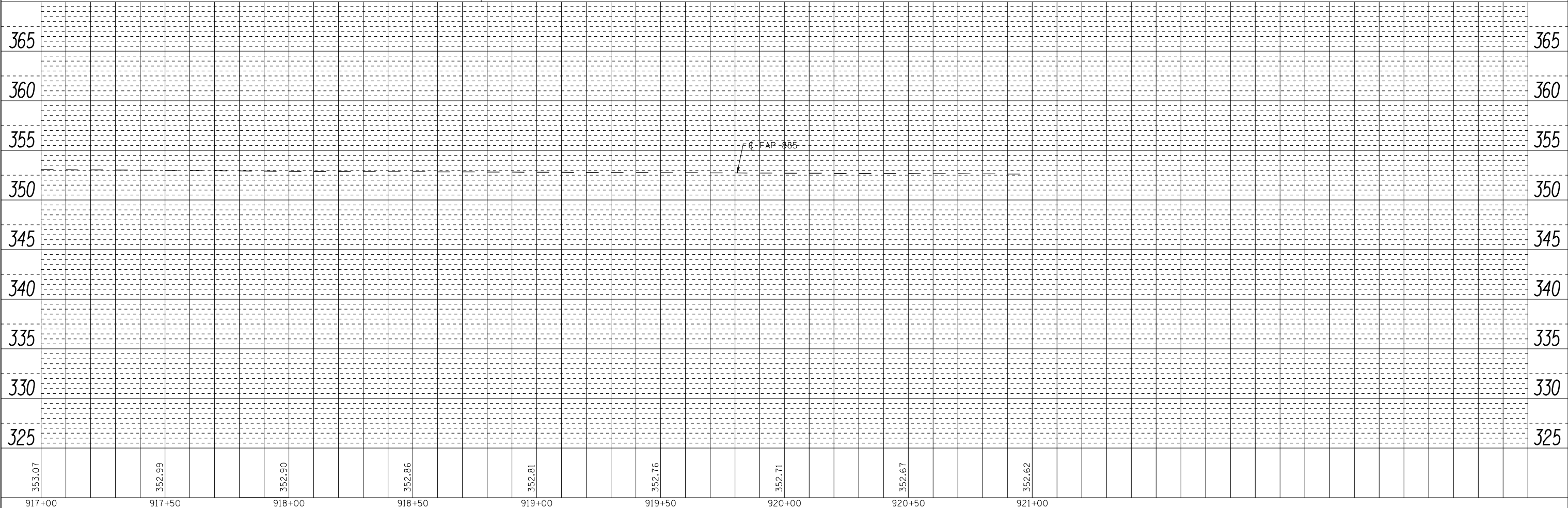

	917+00	917+50	918+00	918+50	919+00	919+50	920+00	920+50	921+00											
353.07		352.99		352.90		352.86		352.81		352.76		352.71		352.67		352.62			365	365



USER NAME = hos	DESIGNED - JMS	REVISED -
ESCA PROJECT NO. 988.07	DRAWN - RJT/HAS	REVISED -
SCALEs: (HORIZ) 1"=20' (VERT) 1"=5'	CHECKED - RDP	REVISED -
PLOT DATE = 8/2/2013 11:31:21 AM	DATE - 03/13	REVISED -

**STATE OF ILLINOIS  
DEPARTMENT OF TRANSPORTATION**

**FAP 885 (IL 146) PLAN & PROFILE**

SCALE: AS SHOWN    SHEET NO. 3 OF 3 SHEETS    STA. 917+00    TO STA. 921+00

F.A.P. RTE.	SECTION	COUNTY	TOTAL SHEETS	SHEET NO.
885	112B-1	POPE	56	16
CONTRACT NO. 78230				
FED. ROAD DIST. NO. 9 ILLINOIS FED. AID PROJECT AID				

PRINT DRIVER = L:\D.L.R. & J.L. MODEL MAKE = PLOT: WENZ.TBL FILE NAME = D:\9230-act-112B-01.dgn



**SCHEDULE OF QUANTITIES**

TEMPORARY CONCRETE BARRIER

STATION	TO	STATION	FEET
911+38		915+63	425

TEMPORARY BRIDGE TRAFFIC SIGNALS - 1 EACH

IMPACT ATTENUATORS, TEMPORARY (NON-REDIRECTIVE), TEST LEVEL 3 - 2 EACH

**LEGEND**

- TRAFFIC SIGNAL WITH BACKPLATE, SIGNAL DIRECTION INDICATED
- DETECTOR LOOP
- DRUM WITH STEADY BURNING BI-DIRECTIONAL LIGHT
- TYPE III BARRICADE
- BASE COURSE WIDENING, 10"
- PAVEMENT REMOVAL
- HMA SHOULDER, 8"
- IMPACT ATTENUATORS (TEMPORARY NON-REDIRECTIVE) TEST LEVEL 3

**GENERAL NOTES**

- PRE-STAGE I: CONSTRUCT THE BASE COURSE FROM LT. STA. 911+50 TO LT. STA. 915+50 AS SHOWN ON THIS SHEET PRIOR TO PLACING THE SIGNALS IN OPERATION AND PLACEMENT OF THE TEMPORARY BARRIERS.
- TRAFFIC CONTROL SHALL BE ERECTED AS SHOWN AND ACCORDING TO TRAFFIC CONTROL AND PROTECTION, STANDARD 701321. SEE STANDARD 701321 FOR THE COMPLETION OF THE STAGE CONSTRUCTION TRAFFIC CONTROL THAT IS NOT SHOWN THAT INCLUDES, BUT IS NOT LIMITED TO, ADVANCE SIGNING, ADVANCE LOOP PLACEMENT, DRUMS WITH STEADY BURNING LIGHTS, DOUBLE VERTICAL PANELS AND BARRIER WALL/ GUARDRAIL MARKERS.
- SEE SPECIAL PROVISIONS FOR ADDITIONAL TRAFFIC CONTROL REQUIREMENTS.
- COORDINATE LOCATION OF SIGNALS WITH FINAL WORK AS DIRECTED BY THE ENGINEER.
- ADVANCE WIDTH RESTRICTION WARNING SHALL BE INCLUDED IN THE COST OF STANDARD 701321.
- THE DIMENSION SHOWN ON THE WIDTH RESTRICTION SIGN (W12-1102(O)-48) SHOWN ON STANDARD 701321 AND ON THE ADVANCE WARNING SIGN (W12-1103) SHOWN ON SHEET 18 SHALL BE 10'-6" FOR STAGE I CONSTRUCTION.
- THE ADVANCE DETECTOR LOOPS ARE TYPICALLY LOCATED 275 FEET IN ADVANCE OF THE STOP BAR, THE BUREAU OF OPERATIONS SHOULD APPROVE THE LOOP LOCATIONS PRIOR TO INSTALLATION.

- THE CENTERLINE PAVEMENT MARKING SHOULD BE REMOVED FROM THE STOP BAR TO THE SAND ATTENUATORS OR DRUMS. EDGE LINE PAVEMENT MARKING SHOULD BE REMOVED IF A 10 FOOT LANE WIDTH CANNOT BE MAINTAINED. TEMPORARY EDGE LINES SHOULD BE INSTALLED WHEN THE EDGE LINES ARE REMOVED.
- VERTICAL PANELS SHOWN ON STANDARD 701321 WILL NOT BE REQUIRED ON THE STAGE II NEW BRIDGE PARAPET. THE BARRIER WALL REFLECTORS SHALL BE INSTALLED PRIOR TO OPENING TO TRAFFIC.
- ANY TIME THE CONCRETE BARRIER IS NOT IN THE PROPER POSITION, FLAGGERS SHALL BE IN PLACE TO CONTROL TRAFFIC AND THE TEMPORARY TRAFFIC SIGNALS SHALL BE TURNED OFF OR COVERED.
- THE STAGE I CONSTRUCTION SHALL INCLUDE COMPLETION OF THE EARTHWORK, BASE COURSE, HMA SHOULDERS, GUARDRAIL AND TRAFFIC BARRIER TERMINALS FROM RT. STA. 911+19 TO RT. STA. 915+50 AS REFERENCED ON THIS SHEET AND DESCRIBED IN DETAIL ON THE PLAN AND PROFILE SHEETS. THE LEVELING BINDER (MACHINE METHOD) AND THE HMA SURFACE COURSE SHALL ALSO BE PLACED ON THE TRAFFIC LANE ADJACENT TO THE PROPOSED HMA SHOULDERS TO ALLOW COMPLETION OF THE HMA SHOULDERS PRIOR TO THE INSTALLATION OF THE GUARDRAIL AND TERMINALS. PLACEMENT OF THE LEVELING BINDER AND HMA SURFACE AS INDICATED MAY REQUIRE RELOCATION OF THE TEMPORARY BARRIERS AND THE IMPACT ATTENUATORS DURING THE DAYTIME HOURS AND ALSO PLACEMENT OF A TEMPORARY RAMP IN ACCORDANCE WITH ARTICLE 406.08 OF THE STANDARD SPECIFICATIONS. THE CONTRACTOR WILL SUBMIT A WRITTEN PLAN TO THE ENGINEER FOR APPROVAL THAT DETAILS THE STAGING OF THE HMA RESURFACING FOR STAGE I CONSTRUCTION TO MEET THESE REQUIREMENTS. THE COST ASSOCIATED WITH THE STAGING OF THE HMA RESURFACING, INCLUDING THE TEMPORARY RAMP, WILL NOT BE PAID FOR SEPARATELY BUT WILL BE INCLUDED IN THE COST OF THE VARIOUS HMA PAY ITEMS INCLUDED IN THE PLANS.

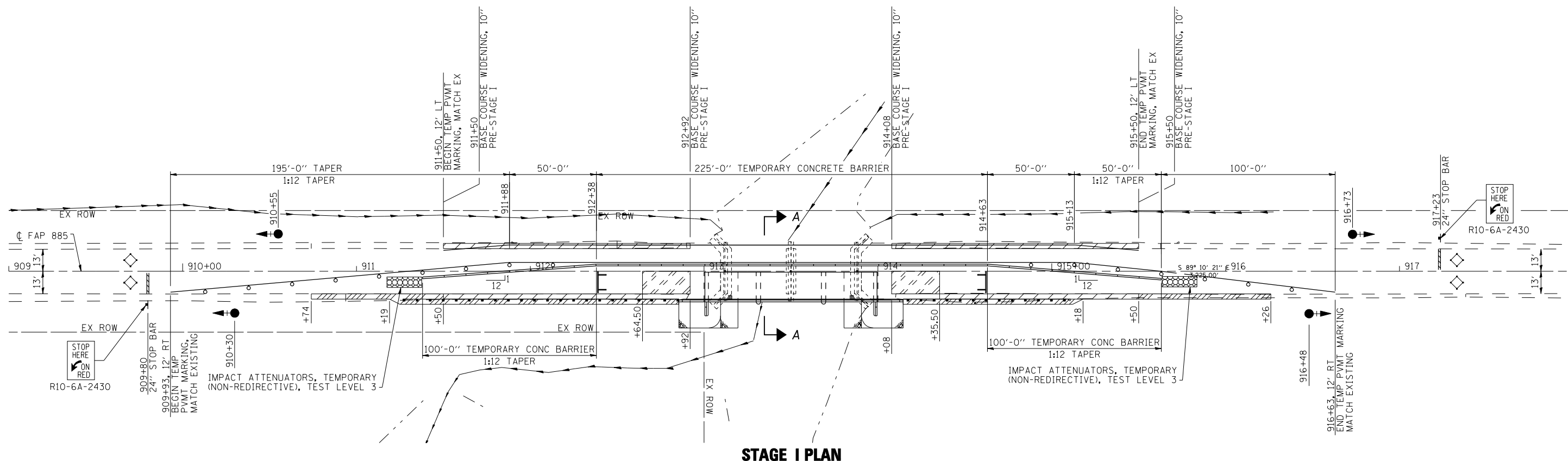
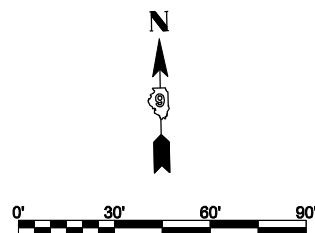

**STAGE I PLAN**

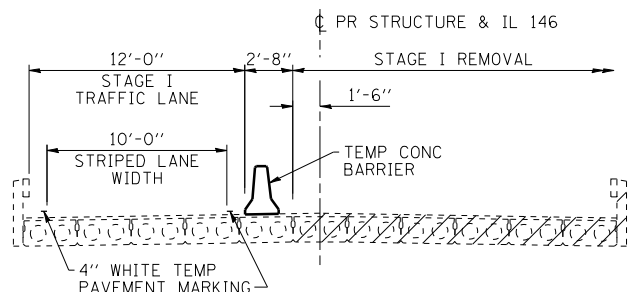

**SECTION A-A  
REMOVAL**

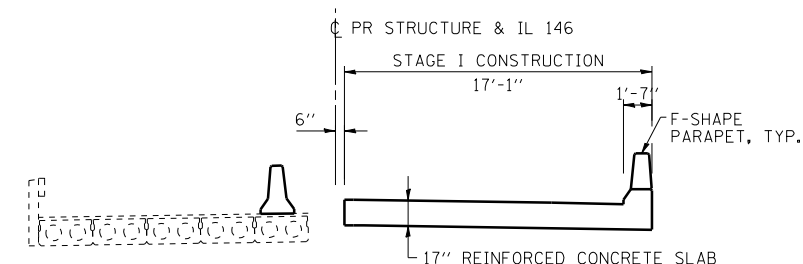

**SECTION A-A  
CONSTRUCTION**

PRINT DRIVER: L:\D-888\B\111111\111111.dwg



USER NAME = has	DESIGNED - JMS	REVISED -
ESCA PROJECT NO. 988.12	DRAWN - HAS	REVISED -
PLOT SCALE = 0.1667' / IN.	CHECKED - RDP	REVISED -
PLOT DATE = 8/2/2013 11:31:50 AM	DATE - 03/13	REVISED -

**STATE OF ILLINOIS  
DEPARTMENT OF TRANSPORTATION**

**STAGE CONSTRUCTION PLAN AND DETAILS  
STRUCTURE NO. 076-0032**

SCALE: 1"=30'-0" SHEET NO. 1 OF 2 SHEETS STA. 909+00 TO STA. 918+00

F.A.P. RTE.	SECTION	COUNTY	TOTAL SHEETS	SHEET NO.
885	112B-1	POPE	56	17
CONTRACT NO. 78230				
FED. ROAD DIST. NO. ILLINOIS FED. AID PROJECT AID				

**SCHEDULE OF QUANTITIES**

RELOCATE  
 TEMPORARY CONCRETE BARRIER

STATION	TO	STATION	FEET
911+50.5		915+50.5	400

IMPACT ATTENUATORS, RELOCATE  
 (NON-REDIRECTIVE), TEST LEVEL 3 - 2 EACH

**LEGEND**

- TRAFFIC SIGNAL WITH BACKPLATE, SIGNAL DIRECTION INDICATED
- DETECTOR LOOP
- DRUM WITH STEADY BURNING BI-DIRECTIONAL LIGHT
- TYPE III BARRICADE
- BASE COURSE WIDENING, 10"
- PAVEMENT REMOVAL
- HMA SHOULDER, 8"
- IMPACT ATTENUATORS (TEMPORARY NON-REDIRECTIVE) TEST LEVEL 3

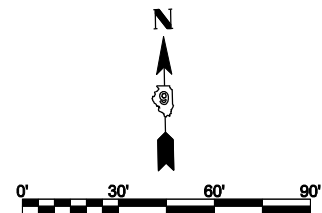

**GENERAL NOTES**

- TRAFFIC CONTROL SHALL BE ERRECTED AS SHOWN AND ACCORDING TO TRAFFIC CONTROL AND PROTECTION, STANDARD 701321. SEE STANDARD 701321 FOR THE COMPLETION OF THE STAGE CONSTRUCTION TRAFFIC CONTROL THAT IS NOT SHOWN THAT INCLUDES, BUT IS NOT LIMITED TO, ADVANCE SIGNING, ADVANCE LOOP PLACEMENT, DRUMS WITH STEADY BURNING LIGHTS, DOUBLE VERTICAL PANELS AND BARRIER WALL/ GUARDRAIL MARKERS.
- SEE SPECIAL PROVISIONS FOR ADDITIONAL TRAFFIC CONTROL REQUIREMENTS.
- COORDINATE LOCATION OF SIGNALS WITH FINAL WORK AS DIRECTED BY THE ENGINEER.
- ADVANCE WIDTH RESTRICTION WARNING SHALL BE INCLUDED IN THE COST OF STANDARD 701321.
- THE DIMENSION SHOWN ON THE WIDTH RESTRICTION SIGN (W12-1102(O)-48) SHOWN ON STANDARD 701321 AND ON THE ADVANCE WARNING SIGN (W12-1103) SHOWN ON THIS SHEET SHALL BE 11'-6" FOR STAGE II CONSTRUCTION.
- THE ADVANCE DETECTOR LOOPS ARE TYPICALLY LOCATED 275 FEET IN ADVANCE OF THE STOP BAR. THE BUREAU OF OPERATIONS SHOULD APPROVE THE LOOP LOCATIONS PRIOR TO INSTALLATION.
- THE CENTERLINE PAVEMENT MARKING SHOULD BE REMOVED FROM THE STOP BAR TO THE SAND ATTENUATORS OR DRUMS. EDGE LINE PAVEMENT MARKING SHOULD BE REMOVED IF A 10 FOOT LANE WIDTH CANNOT BE MAINTAINED. TEMPORARY EDGE LINES SHOULD BE INSTALLED WHEN THE EDGE LINES ARE REMOVED.
- VERTICAL PANELS SHOWN ON STANDARD 701321 WILL NOT BE REQUIRED ON THE STAGE II NEW BRIDGE PARAPET. THE BARRIER WALL REFLECTORS SHALL BE INSTALLED PRIOR TO OPENING TO TRAFFIC.
- ANY TIME THE CONCRETE BARRIER IS NOT IN THE PROPER POSITION, FLAGGERS SHALL BE IN PLACE TO CONTROL TRAFFIC AND THE TEMPORARY TRAFFIC SIGNALS SHALL BE TURNED OFF OR COVERED.
- THE TEMPORARY SIGNALS WILL REMAIN IN OPERATION AND THE TEMPORARY BARRIERS WILL REMAIN IN PLACE UNTIL THE BRIDGE SUPERSTRUCTURE IS COMPLETE INCLUDING PARAPETS AND APPROACH PAVEMENT. THE REMAINING HMA RESURFACING, HMA SHOULDERS, GUARDRAIL, AND TRAFFIC BARRIER TERMINALS SHALL BE COMPLETED USING THE APPROPRIATE STANDARDS INCLUDED IN THE PLANS AND TRAFFIC SHALL BE OPEN TO BOTH LANES DURING NON-WORKING HOURS. THE CONTRACTOR SHALL SCHEDULE THEIR OPERATIONS SO THERE IS NO MORE THAN TWO WEEKS BETWEEN THE REMOVAL OF THE TEMPORARY BARRIERS AND THE START OF GUARDRAIL AND TERMINAL INSTALLATION.
- THE CONTRACTOR'S OPERATION MAY RESULT IN A DROP-OFF AT THE END OF THE BRIDGE APPROACH PAVEMENT THAT IS UNDER TRAFFIC PRIOR TO THE HMA RESURFACING. TEMPORARY RAMPS SHALL BE PROVIDED AT THESE LOCATIONS IF NEEDED ACCORDING TO ARTICLE 406.08 OF THE STANDARD SPECIFICATIONS. THE COST FOR THE TEMPORARY RAMPS AT THESE LOCATIONS WILL NOT BE PAID FOR SEPARATELY BUT WILL BE INCLUDED IN THE COST OF VARIOUS HMA PAY ITEMS INCLUDED IN THE PLANS.

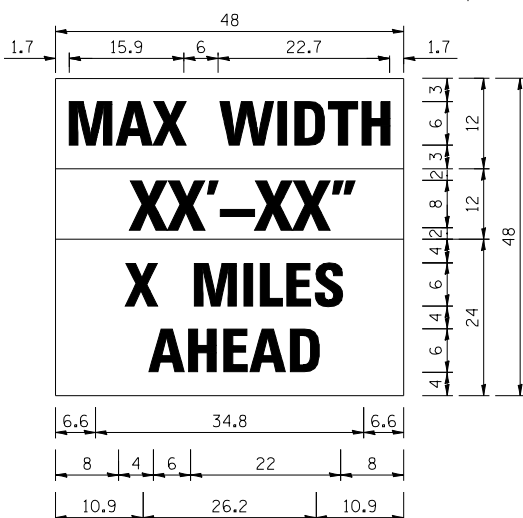
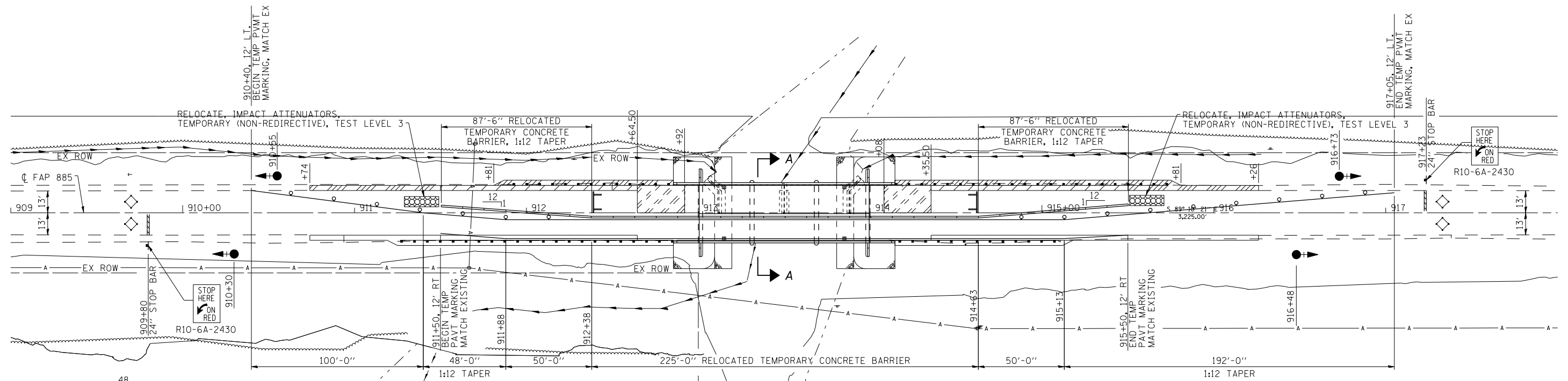

**W12-1103**

W12-1103 (Width is 8D);  
 No border, Black on White;  
 "MAX WIDTH" D;  
 No border, Black on Orange;  
 "XX'-XX''" D;  
 No border, Black on White;  
 "X MILES" D; "AHEAD" D

**STAGE II PLAN**

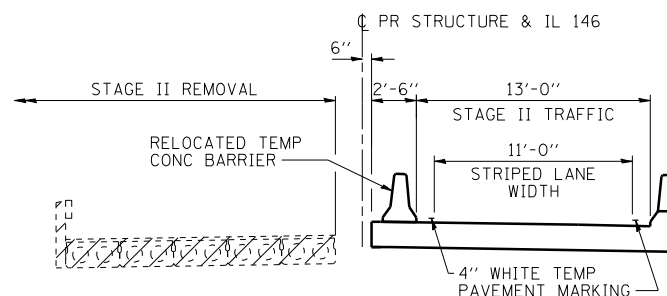

**SECTION A-A  
 REMOVAL**

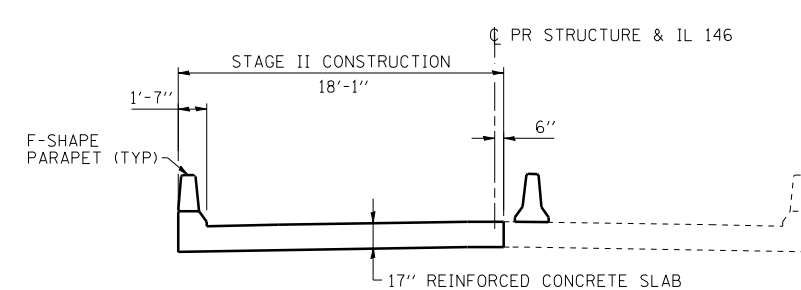

**SECTION A-A  
 CONSTRUCTION**

NOTE: THIS SIGN SHALL BE LOCATED AS DIRECTED BY THE ENGINEER. ONE SIGN SHALL BE PROVIDED FOR EACH APPROACH TO THE SITE.

STATE OF ILLINOIS  
 DEPARTMENT OF TRANSPORTATION

STAGE CONSTRUCTION PLAN AND DETAILS  
 STRUCTURE NO. 076-0032





SCALE: 1"=30'-0" SHEET NO. 2 OF 2 SHEETS STA. 909+00 TO STA. 918+00

F.A.P. RTE.	SECTION	COUNTY	TOTAL SHEETS	SHEET NO.
885	112B-1	POPE	56	18
CONTRACT NO. 78230				
FED. ROAD DIST. NO. ILLINOIS FED. AID PROJECT AID				

PRINT DRIVER: L:\05-ESCA\B\112B-1\112B-1.dwg  
 SCALE: 1"=30'-0"  
 FILE NAME: 112B-1.dwg  
 DATE: 8/2/2013 11:32:14 AM



USER NAME = has	DESIGNED - JMS	REVISED -
ESCA PROJECT NO. 988.12	DRAWN - HAS	REVISED -
PLOT SCALE = 0.1667' / IN.	CHECKED - RDP	REVISED -
PLOT DATE = 8/2/2013 11:32:14 AM	DATE - 03/13	REVISED -

- LEGEND**
-  SEEDING CLASS 2A AND EROSION CONTROL BLANKET
  -  PERIMETER EROSION BARRIER
  -  STONE RIPRAP CLASS A5
  -  WETLAND AREA

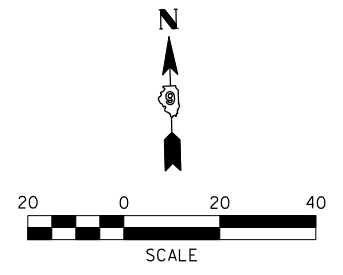

STATIONS AND OFFSETS SHOWN ARE TO THE CONSTRUCTION LIMITS.  
 THE PERIMETER EROSION BARRIER WILL BE PLACED 1'-0" OUTSIDE THE CONSTRUCTION LIMITS. THE SEEDING CLASS 2A AND EROSION CONTROL BLANKET WILL BE PLACED TO THE LIMITS OF THE PERIMETER EROSION BARRIER.

WETLAND SITE DISTURBANCE INSIDE OF CONSTRUCTION LIMITS TO BE MINIMAL.  
 WETLAND SITES OUTSIDE OF CONSTRUCTION LIMITS ARE NOT TO BE DISTURBED.

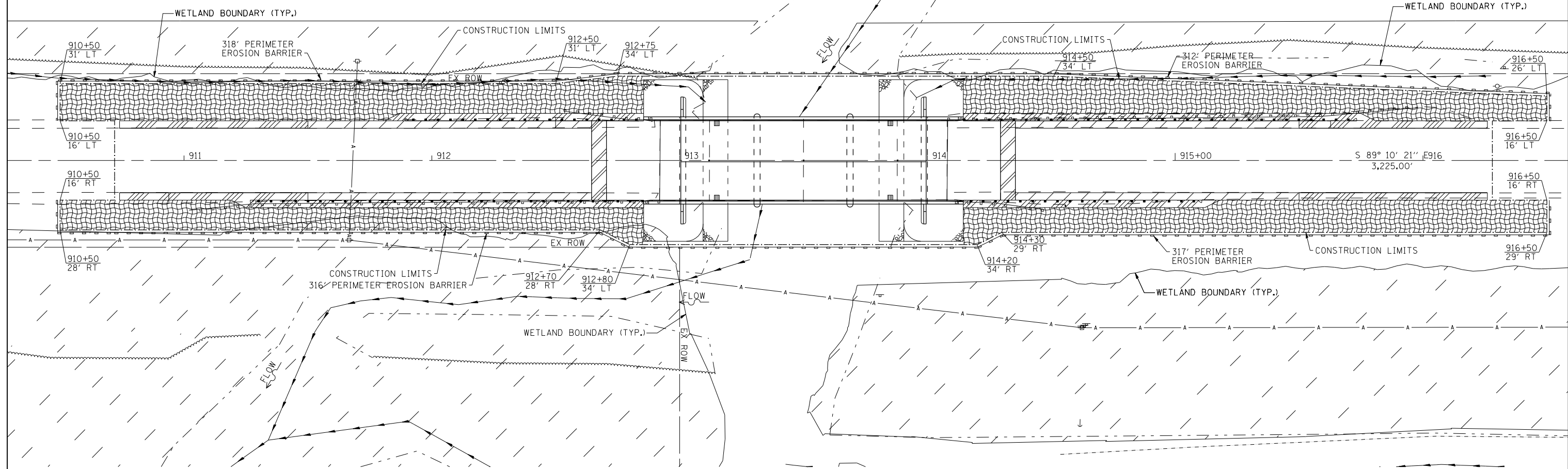

PRINT DRIVER = L:\04-ESCA\0411 ESCA PROJECT NO. 988.12  
 SCALE = 1"=30'-0"  
 FILE NAME = D:\2013\112B-112B-1.dwg



USER NAME = has	DESIGNED - JMS	REVISED -
ESCA PROJECT NO. 988.12	DRAWN - HAS	REVISED -
PLOT SCALE = 0.1667' / IN.	CHECKED - RDP	REVISED -
PLOT DATE = 8/2/2013 11:32:46 AM	DATE - 03/13	REVISED -

**STATE OF ILLINOIS  
 DEPARTMENT OF TRANSPORTATION**

**EROSION CONTROL PLAN**

SCALE: 1"=30'-0" SHEET NO. 1 OF 1 SHEETS STA. 910+50 TO STA. 916+50

F.A.P. RTE.	SECTION	COUNTY	TOTAL SHEETS	SHEET NO.
885	112B-1	POPE	56	19
		CONTRACT NO. 78230		
FED. ROAD DIST. NO.		ILLINOIS FED. AID PROJECT AID		

# SEEDING & MULCHING

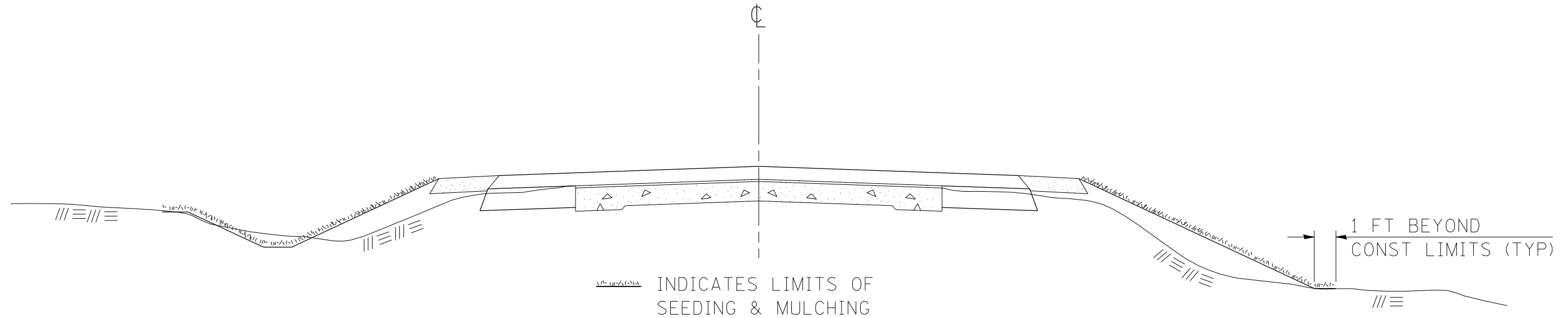

## GENERAL NOTES

IN GENERAL, ALL EARTH SURFACES DISTURBED DURING CONSTRUCTION OPERATIONS SHALL BE SEEDED AND MULCHED UPON COMPLETION OF ALL GRADING OPERATIONS.

FERTILIZER NUTRIENTS AND LIMESTONE SHALL BE APPLIED TO ALL SEEDED AREAS.

SECTIONS 250 AND 251 OF THE STANDARD SPECIFICATIONS SHALL GOVERN THIS WORK EXCEPT AS SPECIFIED HEREIN OR AS NOTED IN THE SPECIAL PROVISIONS.

### REVISIONS

REDRAWN	_2-15-89
REVISED	_8-15-94
REVISED	_6-3-99
REVISED	_3-27-08

STD. \_9-12

ESCA CONSULTANTS, INC. 1111 W. MONROE ST. SUITE 200, CHICAGO, IL 60606  
 TEL: (773) 344-1111 FAX: (773) 344-1112  
 WWW.ESCA-CONSULTANTS.COM



USER NAME = has	DESIGNED - JMS	REVISED -
ESCA PROJECT NO. 988.12	DRAWN - HAS	REVISED -
PLOT SCALE = 0.1667' / IN.	CHECKED - RDP	REVISED -
PLOT DATE = 8/2/2013 11:33:21 AM	DATE - 03/13	REVISED -

**STATE OF ILLINOIS  
DEPARTMENT OF TRANSPORTATION**

### SEEDING AND MULCHING DETAILS

SCALE: SHEET NO. 1 OF 1 SHEETS STA. TO STA.

F.A.P. RTE.	SECTION	COUNTY	TOTAL SHEETS	SHEET NO.
885	112B-1	POPE	56	20
FED. ROAD DIST. NO. ILLINOIS FED. AID PROJECT			CONTRACT NO. 78230	

# TYPICAL CROSS SECTION SHOWING STEP CONSTRUCTION ON EXISTING FILL

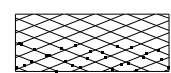
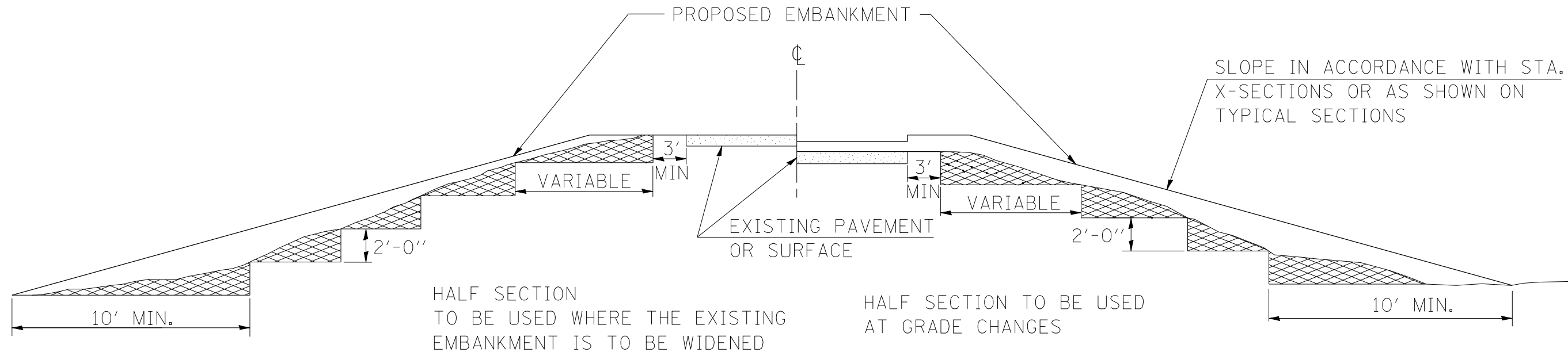

MATERIAL TO BE REMOVED AND REPLACED IN THE EMBANKMENT IN ACCORDANCE WITH ART. 205.04 OF THE STANDARD SPECIFICATION. COST TO BE INCLUDED IN THE VARIOUS ITEMS OF EXCAVATION AND NO ADDITIONAL COMPENSATION WILL BE ALLOWED BECAUSE OF THIS WORK.

REVISIONS	
REDRAWN	_2-15-89
REVISED	_8-15-94
CHECKED	_6-3-99
RESIZED	5-7-08

STD. \_9-16



USER NAME = has	DESIGNED - JMS	REVISED -
ESCA PROJECT NO. 988.12	DRAWN - HAS	REVISED -
PLOT SCALE = 0.1667' / IN.	CHECKED - RDP	REVISED -
PLOT DATE = 8/2/2013 11:33:39 AM	DATE - 03/13	REVISED -

**STATE OF ILLINOIS  
DEPARTMENT OF TRANSPORTATION**

**STEP CONSTRUCTION ON EXISTING FILL DETAILS**

SCALE: SHEET NO. 1 OF 1 SHEETS STA. TO STA.

F.A.P. RTE.	SECTION	COUNTY	TOTAL SHEETS	SHEET NO.
885	112B-1	POPE	56	21
FED. ROAD DIST. NO. ILLINOIS FED. AID PROJECT			CONTRACT NO. 78230	

# BUTT JOINT

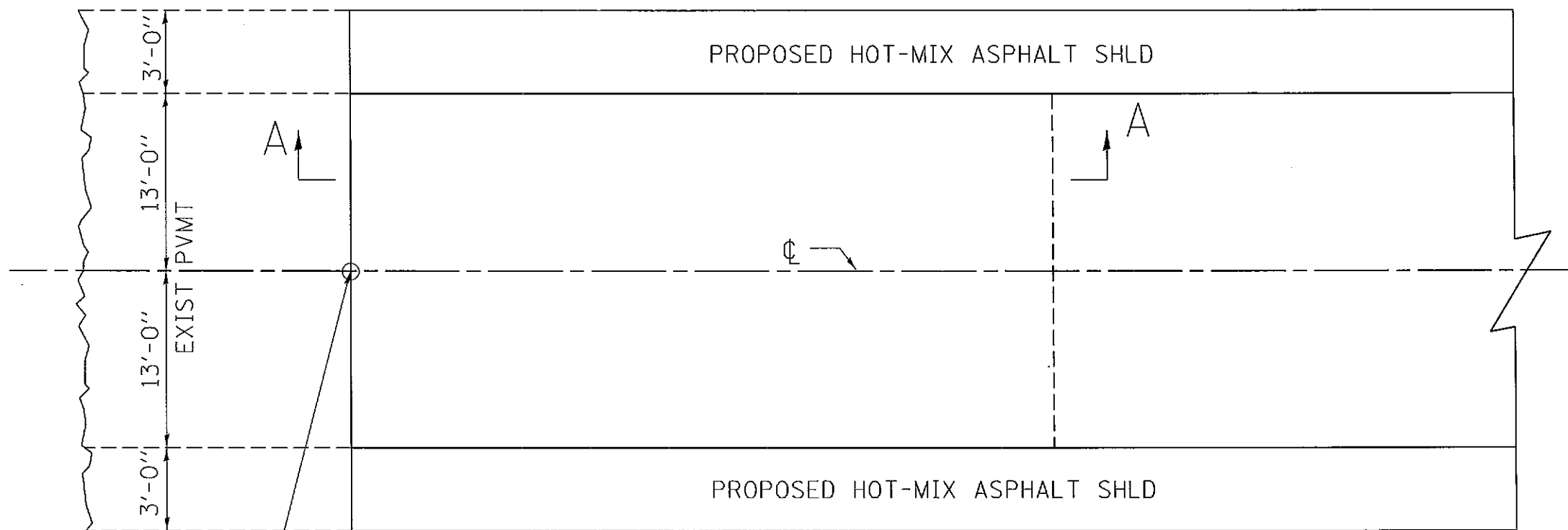

STA 910+74  
STA 916+26

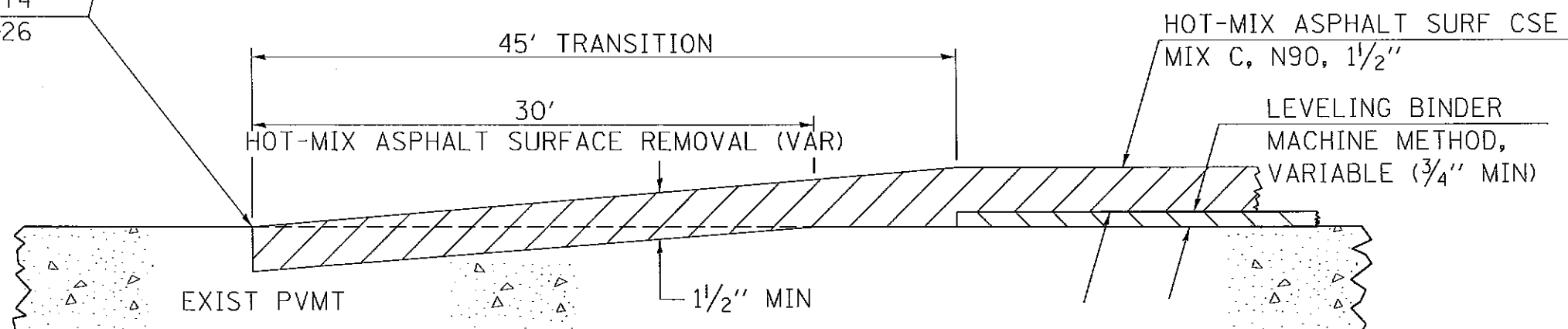

## SECTION A-A

REVISIONS	
DRAWN	10-17-90
REVISED	01-11-07
REVISED	3-25-08
REVISED	

STD. 9-86



USER NAME = halsteadw	DESIGNED - JMS	REVISED -
ESCA PROJECT NO. 988.12	DRAWN - HAS	REVISED -
PLOT SCALE = 0.1667" / 1"	CHECKED - RDP	REVISED -
PLOT DATE = 8/15/2013 9:41:46 AM	DATE - 03/13	REVISED -

**STATE OF ILLINOIS  
DEPARTMENT OF TRANSPORTATION**

**BUTT JOINT DETAIL**

SCALE: SHEET NO. 1 OF 1 SHEETS STA. TO STA.

F.A.P. RTE. 885	SECTION 1128-1	COUNTY POPE	TOTAL SHEETS 56	SHEET NO. 22
FED. ROAD DIST. NO. ILLINOIS FED. AID PROJECT			CONTRACT NO. 78230	



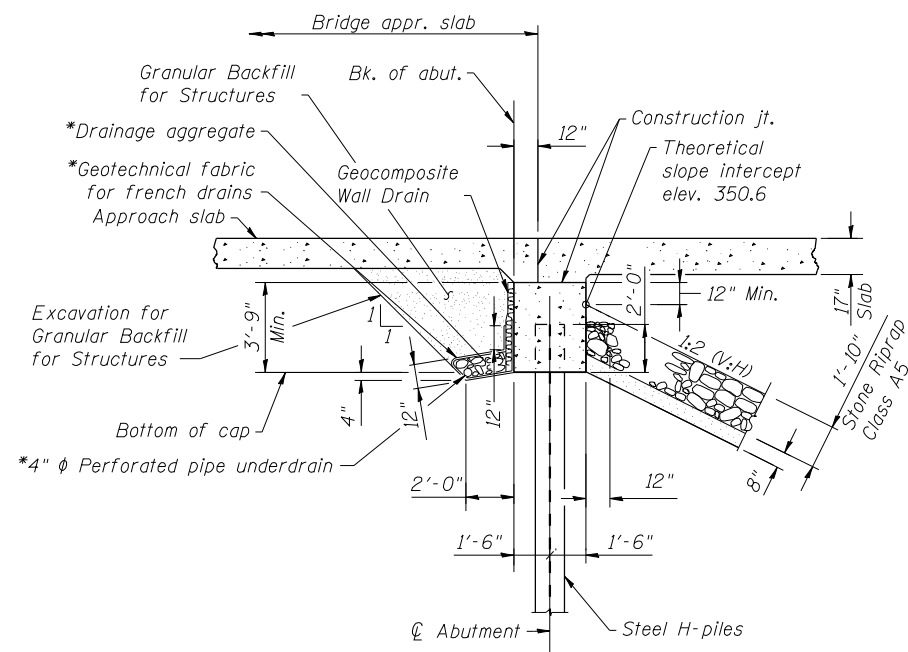

**SECTION THRU INTEGRAL ABUTMENT**

\* Included in the cost of Pipe Underdrains for Structures.

All drainage system components shall extend to 2'-0" from the end of each wingwall except an outlet pipe shall extend until intersecting with the side slopes. The pipes shall drain into concrete headwalls. (See Article 601.05 of the Standard Specifications and Highway Standard 60110).

**GENERAL NOTES**

1. The Contractor shall make allowance for the deflection of forms, shrinkage and settlement of falsework, in addition to allowance for dead load deflection. Forms for deck slab shall be removed prior to placement of bridge approach slab.
2. Reinforcement bars designated (E) shall be epoxy coated.
3. Layout of the slope protection system may be varied to suit ground conditions in the field as directed by the Engineer.
4. Slipforming of parapets is not allowed.

**TOTAL BILL OF MATERIAL**

ITEM	UNIT	SUPER	SUB	TOTAL
Stone Riprap, Class A5	Sq. Yd.	-	370	370
Filter Fabric	Sq. Yd.	-	370	370
Removal of Existing Structures	Each	-	-	1
Structure Excavation	Cu. Yd.	-	140	140
Cofferdam Excavation	Cu. Yd.	-	120	120
Cofferdam (Type 1) (Location - 1)	Each	-	1	1
Cofferdam (Type 1) (Location - 2)	Each	-	1	1
Concrete Structures	Cu. Yd.	-	114.7	114.7
Concrete Superstructure	Cu. Yd.	321.7	-	321.7
Bridge Deck Grooving	Sq. Yd.	533	-	533
Protective Coat	Sq. Yd.	682	-	682
Reinforcement Bars, Epoxy Coated	Pound	70470	13750	84220
Bar Splicers	Each	319	140	459
Furnishing Steel Piles HP14x89	Foot	-	1860	1860
Driving Piles	Foot	-	1860	1860
Test Pile Steel HP14x89	Each	-	2	2
Name Plates	Each	1	-	1
Geocomposite Wall Drain	Sq. Yd.	-	44	44
Granular Backfill for Structures	Cu. Yd.	-	66	66
Drainage Scuppers, DS-12M10	Each	4	-	4
Temporary Sheet Piling	Sq. Ft.	-	565	565
Pipe Underdrains for Structures 4"	Foot	-	126	126

PRINT DRIVER = L:\05-EB\0411...  
 ESCA PROJECT NO. 988.12  
 PLOT SCALE = 0:2" = 1' / IN.  
 PLOT DATE = 8/2/2013 11:35:08 AM



USER NAME = has	DESIGNED - SHL 12/12	REVISED -
ESCA PROJECT NO. 988.12	CHECKED - RDP 03/13	REVISED -
PLOT SCALE = 0:2" = 1' / IN.	DRAWN - HAS 12/12	REVISED -
PLOT DATE = 8/2/2013 11:35:08 AM	CHECKED - RDP 06/13	REVISED -

**STATE OF ILLINOIS  
DEPARTMENT OF TRANSPORTATION**

**GENERAL DATA  
STRUCTURE NO. 076-0032**

SHEET NO. 2 OF 21 SHEETS

F.A.P. RTE.	SECTION	COUNTY	TOTAL SHEETS	SHEET NO.
885	112B-1	POPE	56	24
CONTRACT NO. 78230			ILLINOIS FED. AID PROJECT AID	



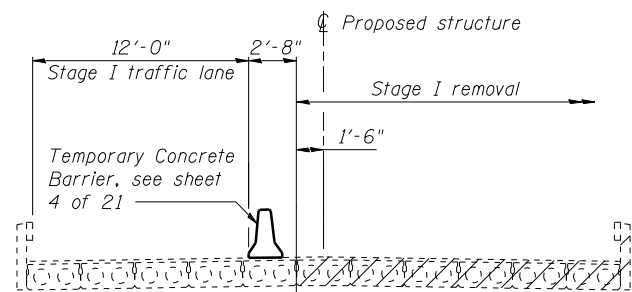

**STAGE I REMOVAL**

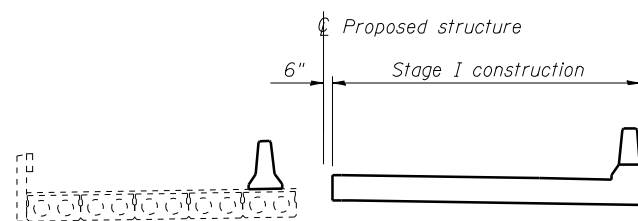

**STAGE I CONSTRUCTION**

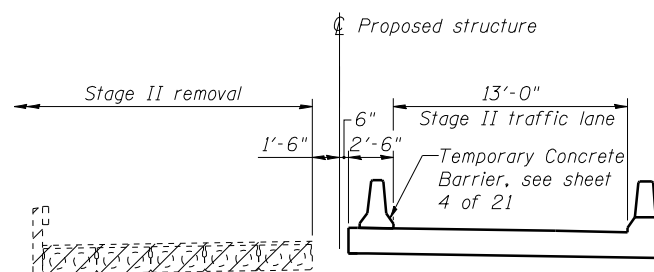

**STAGE II REMOVAL**

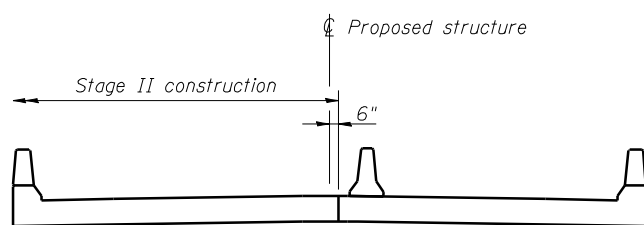

**STAGE II CONSTRUCTION**

**STAGE CONSTRUCTION NOTES**

1. Hatched areas indicate Removal of Existing Structures.
2. All staging sections looking East.
3. For quantities of Temporary Concrete Barrier see roadway plans.

**TEMPORARY SHEET PILING NOTES**

1. If the Contractor chooses to alter the temporary cantilevered sheet piling design requirements shown on the plans, a design submittal including plan details and calculations will be required for review and acceptance by the Engineer.
2. Existing structure details are taken from existing plans.
3. The cost of additional steel closure plates required is included in Temporary Sheet Piling.
4. The Contractor shall connect the first sheet to the existing abutment wall to ensure stability of sheets driven to the top of the existing footing. This connection shall be reviewed and accepted by the Engineer and included in the cost for Temporary Sheet Piling.

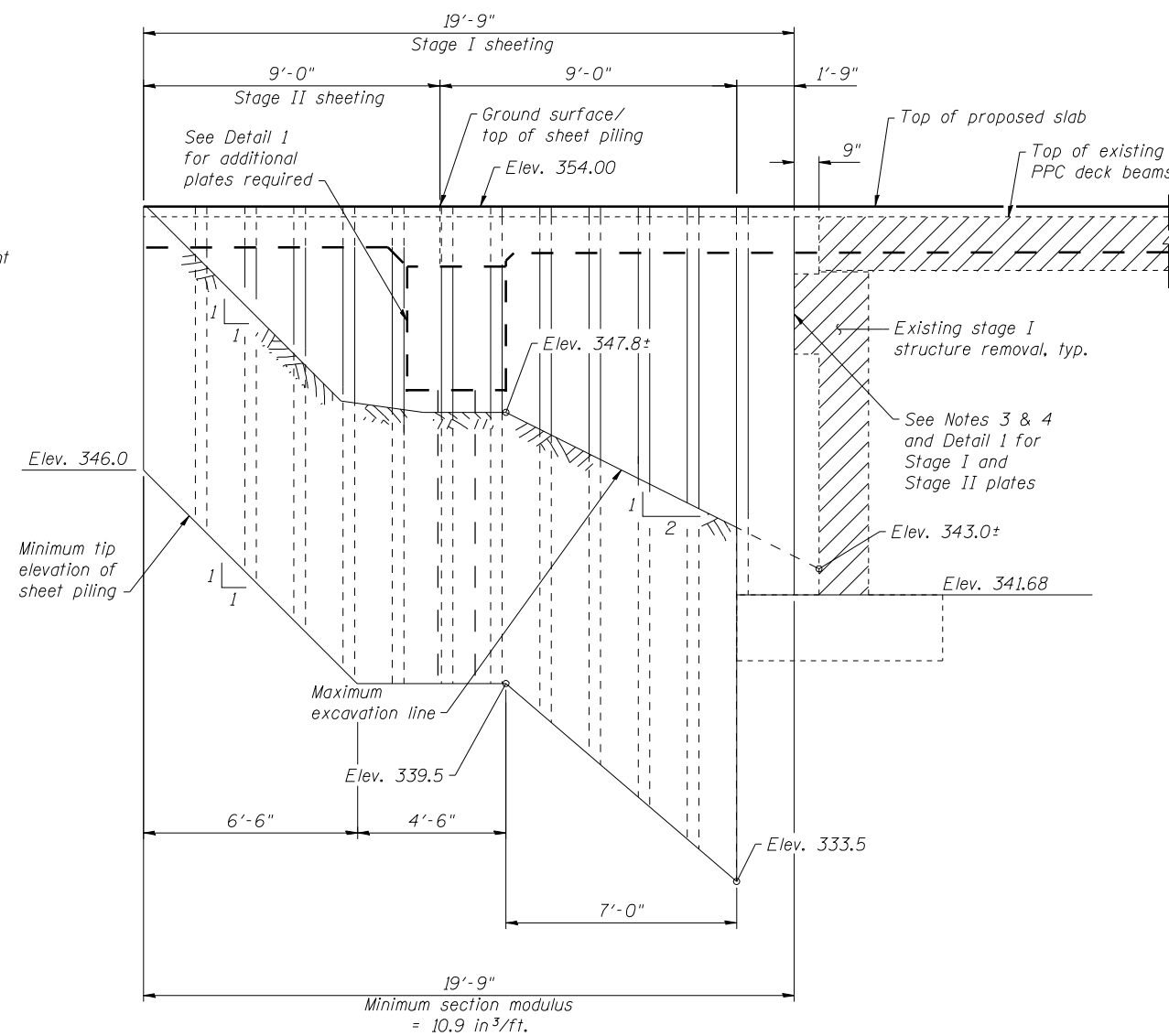

**TEMPORARY SHEET PILING**

(West Abutment shown)  
(East Abutment similar)

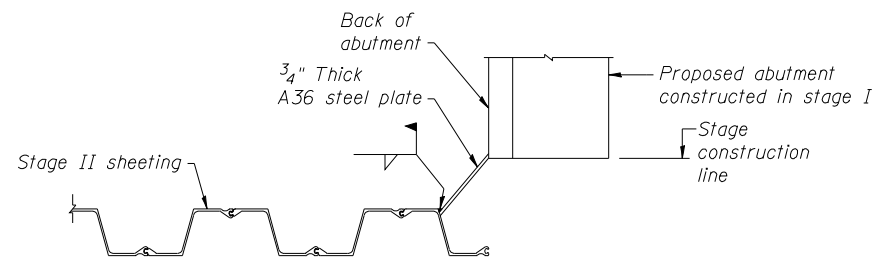

**DETAIL 1**

PRINT DRIVER = LUD-EB@AHL  
 PLOT DATE = 8/2/2013 11:35:30 AM  
 PLOT SCALE = 0.25" = 1'-0"  
 FILE NAME = I:\PROJECTS\78230-03-STRUCT\11.dwg



USER NAME = has	DESIGNED - SHL 12/12	REVISED -
ESCA PROJECT NO. 988.12	CHECKED - RDP 03/13	REVISED -
PLOT SCALE = 0.25" = 1'-0"	DRAWN - HAS 12/12	REVISED -
PLOT DATE = 8/2/2013 11:35:30 AM	CHECKED - RDP 03/13	REVISED -

**STATE OF ILLINOIS  
DEPARTMENT OF TRANSPORTATION**

**STAGE CONSTRUCTION DETAILS  
STRUCTURE NO. 076-0032**

SHEET NO. 3 OF 21 SHEETS

F.A.P. RTE.	SECTION	COUNTY	TOTAL SHEETS	SHEET NO.
885	112B-1	POPE	56	25
CONTRACT NO. 78230			ILLINOIS FED. AID PROJECT AID	

When "A" is 3'-6" or less, the temporary concrete barrier shall be anchored to the new slab according to Detail I or Detail II. No anchorage is required when "A" is greater than 3'-6".

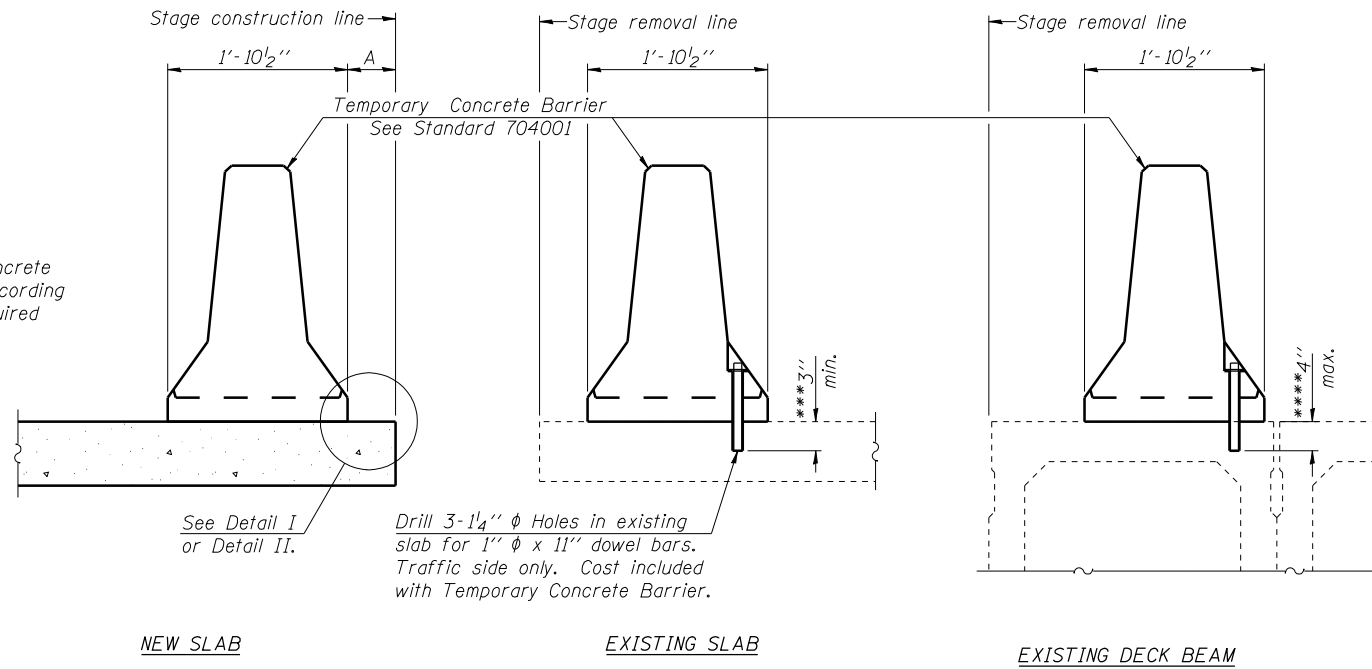

**SECTIONS THRU SLAB OR DECK BEAM**

**NOTES**

Detail I - With Bar Splicer or Couplers:  
Connect one (1) 1" x 7" x "W" steel PL to the top layer of couplers with 2-5/8" φ bolts screwed to coupler at approximate C of each barrier panel.

Detail II - With Extended Reinforcement Bars:  
Connect one (1) 1" x 7" x "W" steel PL to the concrete slab or concrete wearing surface with 2-5/8" φ Expansion Anchors or cast in place inserts spaced between the top layer of reinforcement at approximate C of each barrier panel.

Cost of anchorage is included with Temporary Concrete Barrier. The 1" x 7" x "W" plate shall not be removed until stage II construction forms and all reinforcement bars are in place and the concrete is ready to be placed.

\*\*\* Dimension shown is minimum required embedment into concrete. If hot-mix asphalt wearing surface is present, minimum embedment shall be in addition to wearing surface depth.

\*\*\*\* If existing deck beam is to remain in place after stage construction, embedment shall only be into wearing surface and not into existing deck beam concrete.

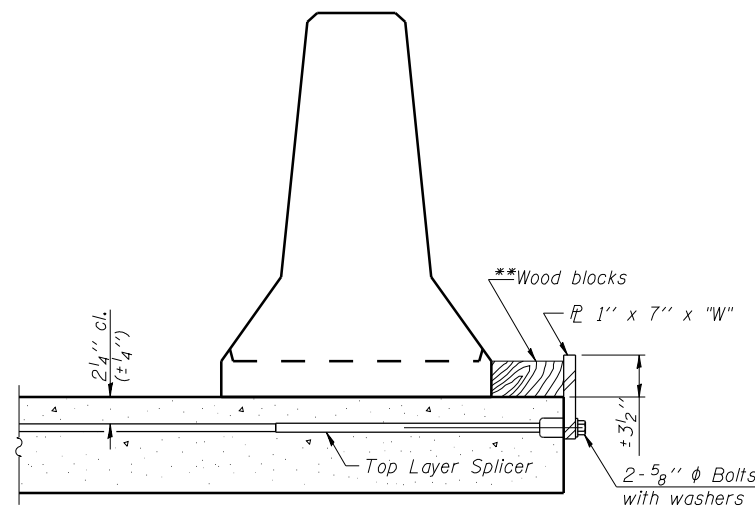

**DETAIL I**

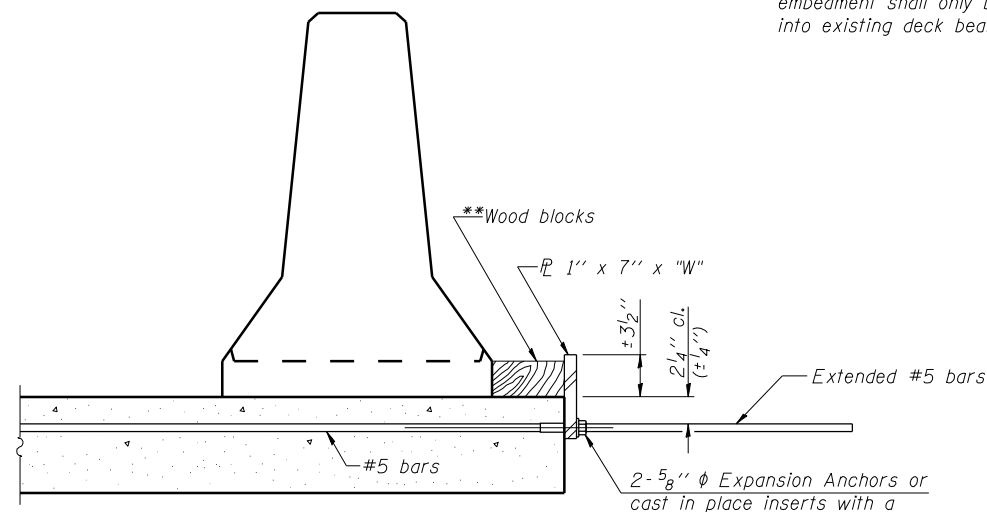

**DETAIL II**

\*\* Wood blocks may be omitted when required to provide minimum stage traffic lane width. When the wood blocks are omitted, the concrete barrier shall be in direct contact with the steel retainer plate.

"W" = Top bars spacing + 4"

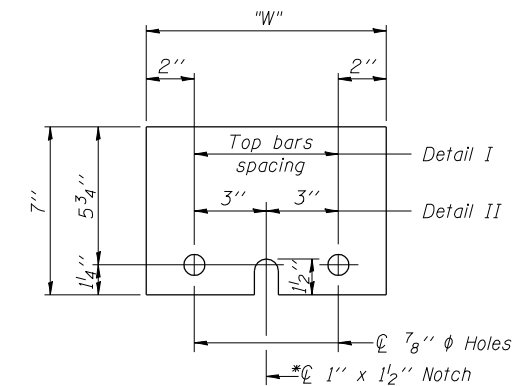

**STEEL RETAINER PL 1" x 7" x "W"**

\* Required only with Detail II

PRINT DRIVER = L:\D-ESCA\B\A\11  
SCALE NAME = PLOT  
FILE NAME = 0760032-78230-04-1CS.dwg

R-27

7-1-10



USER NAME = has	DESIGNED - SHL 12/12	REVISED -
ESCA PROJECT NO. 988.12	CHECKED - RDP 03/13	REVISED -
PLOT SCALE = 0:2 ' / IN.	DRAWN - HAS 12/12	REVISED -
PLOT DATE = 8/2/2013 11:35:51 AM	CHECKED - RDP 03/13	REVISED -

**STATE OF ILLINOIS  
DEPARTMENT OF TRANSPORTATION**

**TEMPORARY CONCRETE BARRIER FOR STAGE CONSTRUCTION  
STRUCTURE NO. 076-0032**

SHEET NO. 4 OF 21 SHEETS

F.A.P. RTE.	SECTION	COUNTY	TOTAL SHEETS	SHEET NO.
885	112B-1	POPE	56	26
CONTRACT NO. 78230			ILLINOIS FED. AID PROJECT AID	

**INSIDE FACE OF NORTH PARAPET**

Location	Station	Offset	Theoretical Grade Elevations	Theoretical Grade Elevations Adjusted For Dead Load Deflection
W. End of Slab	913+00.50	-16.00	353.50	353.50
☉ W. Abut.	913+01.00	-16.00	353.50	353.50
a	913+11.00	-16.00	353.53	353.54
b	913+21.00	-16.00	353.55	353.56
☉ Pier 1	913+31.25	-16.00	353.56	353.56
c	913+41.25	-16.00	353.57	353.58
d	913+51.25	-16.00	353.57	353.59
e	913+61.25	-16.00	353.57	353.58
☉ Pier 2	913+68.75	-16.00	353.56	353.56
f	913+78.75	-16.00	353.55	353.56
g	913+88.75	-16.00	353.53	353.54
☉ E. Abut.	913+99.00	-16.00	353.50	353.50
E. End of Slab	913+99.50	-16.00	353.50	353.50

**NORTH EDGE OF ROADWAY**

Location	Station	Offset	Theoretical Grade Elevations	Theoretical Grade Elevations Adjusted For Dead Load Deflection
W. End of Slab	913+00.50	-12.00	353.58	353.58
☉ W. Abut.	913+01.00	-12.00	353.58	353.58
a	913+11.00	-12.00	353.61	353.62
b	913+21.00	-12.00	353.63	353.64
☉ Pier 1	913+31.25	-12.00	353.64	353.64
c	913+41.25	-12.00	353.65	353.66
d	913+51.25	-12.00	353.65	353.67
e	913+61.25	-12.00	353.65	353.66
☉ Pier 2	913+68.75	-12.00	353.64	353.64
f	913+78.75	-12.00	353.63	353.64
g	913+88.75	-12.00	353.61	353.62
☉ E. Abut.	913+99.00	-12.00	353.58	353.58
E. End of Slab	913+99.50	-12.00	353.58	353.58

**☉ OF STRUCTURE & PROFILE GRADE**

Location	Station	Offset	Theoretical Grade Elevations	Theoretical Grade Elevations Adjusted For Dead Load Deflection
W. End of Slab	913+00.50	0.00	353.77	353.77
☉ W. Abut.	913+01.00	0.00	353.77	353.77
a	913+11.00	0.00	353.80	353.81
b	913+21.00	0.00	353.82	353.83
☉ Pier 1	913+31.25	0.00	353.83	353.83
c	913+41.25	0.00	353.84	353.85
d	913+51.25	0.00	353.84	353.86
e	913+61.25	0.00	353.84	353.85
☉ Pier 2	913+68.75	0.00	353.83	353.83
f	913+78.75	0.00	353.82	353.83
g	913+88.75	0.00	353.80	353.81
☉ E. Abut.	913+99.00	0.00	353.77	353.77
E. End of Slab	913+99.50	0.00	353.77	353.77

**STAGE CONSTRUCTION LINE**

Location	Station	Offset	Theoretical Grade Elevations	Theoretical Grade Elevations Adjusted For Dead Load Deflection
W. End of Slab	913+00.50	0.50	353.76	353.76
☉ W. Abut.	913+01.00	0.50	353.76	353.76
a	913+11.00	0.50	353.79	353.80
b	913+21.00	0.50	353.81	353.82
☉ Pier 1	913+31.25	0.50	353.82	353.82
c	913+41.25	0.50	353.83	353.84
d	913+51.25	0.50	353.83	353.85
e	913+61.25	0.50	353.83	353.84
☉ Pier 2	913+68.75	0.50	353.82	353.82
f	913+78.75	0.50	353.81	353.82
g	913+88.75	0.50	353.79	353.80
☉ E. Abut.	913+99.00	0.50	353.76	353.76
E. End of Slab	913+99.50	0.50	353.76	353.76

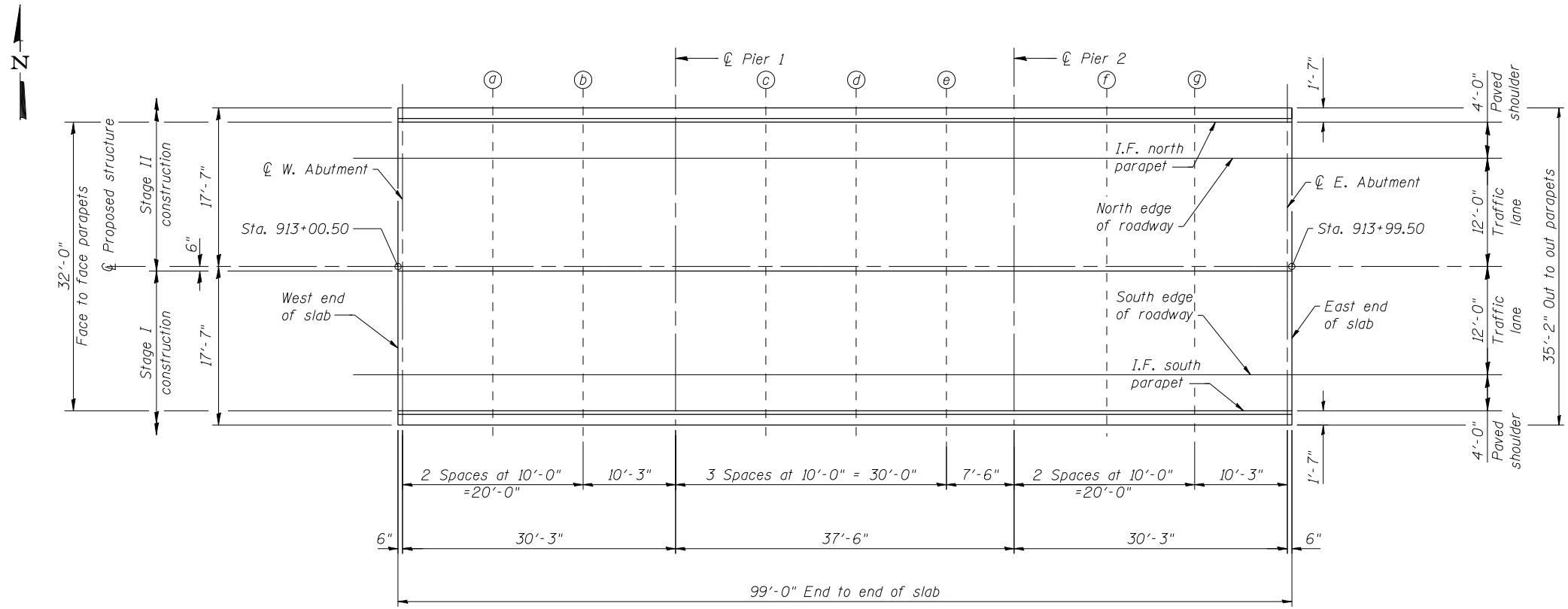

**PLAN**

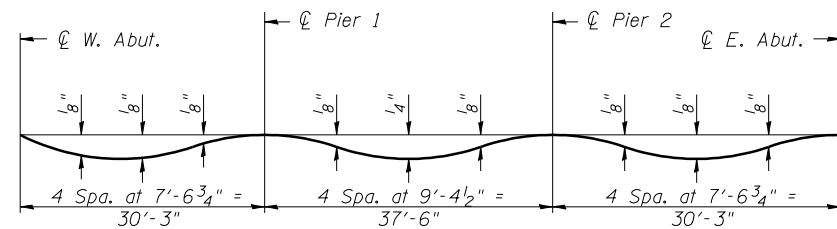

**DEAD LOAD DEFLECTION DIAGRAM**

(Includes weight of concrete only)

Note:

The above deflections are not for use in the field if the Engineer is working from the "Theoretical Grade Elevations Adjusted for Dead Load Deflection."

**SOUTH EDGE OF ROADWAY**

Location	Station	Offset	Theoretical Grade Elevations	Theoretical Grade Elevations Adjusted For Dead Load Deflection
W. End of Slab	913+00.50	12.00	353.58	353.58
☉ W. Abut.	913+01.00	12.00	353.58	353.58
a	913+11.00	12.00	353.61	353.62
b	913+21.00	12.00	353.63	353.64
☉ Pier 1	913+31.25	12.00	353.64	353.64
c	913+41.25	12.00	353.65	353.66
d	913+51.25	12.00	353.65	353.67
e	913+61.25	12.00	353.65	353.66
☉ Pier 2	913+68.75	12.00	353.64	353.64
f	913+78.75	12.00	353.63	353.64
g	913+88.75	12.00	353.61	353.62
☉ E. Abut.	913+99.00	12.00	353.58	353.58
E. End of Slab	913+99.50	12.00	353.58	353.58

**INSIDE FACE OF SOUTH PARAPET**

Location	Station	Offset	Theoretical Grade Elevations	Theoretical Grade Elevations Adjusted For Dead Load Deflection
W. End of Slab	913+00.50	16.00	353.50	353.50
☉ W. Abut.	913+01.00	16.00	353.50	353.50
a	913+11.00	16.00	353.53	353.54
b	913+21.00	16.00	353.55	353.56
☉ Pier 1	913+31.25	16.00	353.56	353.56
c	913+41.25	16.00	353.57	353.58
d	913+51.25	16.00	353.57	353.59
e	913+61.25	16.00	353.57	353.58
☉ Pier 2	913+68.75	16.00	353.56	353.56
f	913+78.75	16.00	353.55	353.56
g	913+88.75	16.00	353.53	353.54
☉ E. Abut.	913+99.00	16.00	353.50	353.50
E. End of Slab	913+99.50	16.00	353.50	353.50

PRINT DRIVER = L:\05-EB\0411  
 SCALE NAME = PLOT  
 FILE NAME = 20130823-78230-05-15104614.dwg



USER NAME = has  
 ESCA PROJECT NO. 988.12  
 PLOT SCALE = 0/2" = 1" / IN.  
 PLOT DATE = 8/2/2013 11:36:13 AM

DESIGNED - SHL 12/12  
 CHECKED - RDP 03/13  
 DRAWN - HAS 12/12  
 CHECKED - RDP 06/13

REVISED -  
 REVISED -  
 REVISED -  
 REVISED -

**STATE OF ILLINOIS**  
**DEPARTMENT OF TRANSPORTATION**

**TOP OF SLAB ELEVATIONS**  
**STRUCTURE NO. 076-0032**

SHEET NO. 5 OF 21 SHEETS

F.A.P. RTE.	SECTION	COUNTY	TOTAL SHEETS	SHEET NO.
885	112B-1	POPE	56	27
CONTRACT NO. 78230			ILLINOIS FED. AID PROJECT AID	

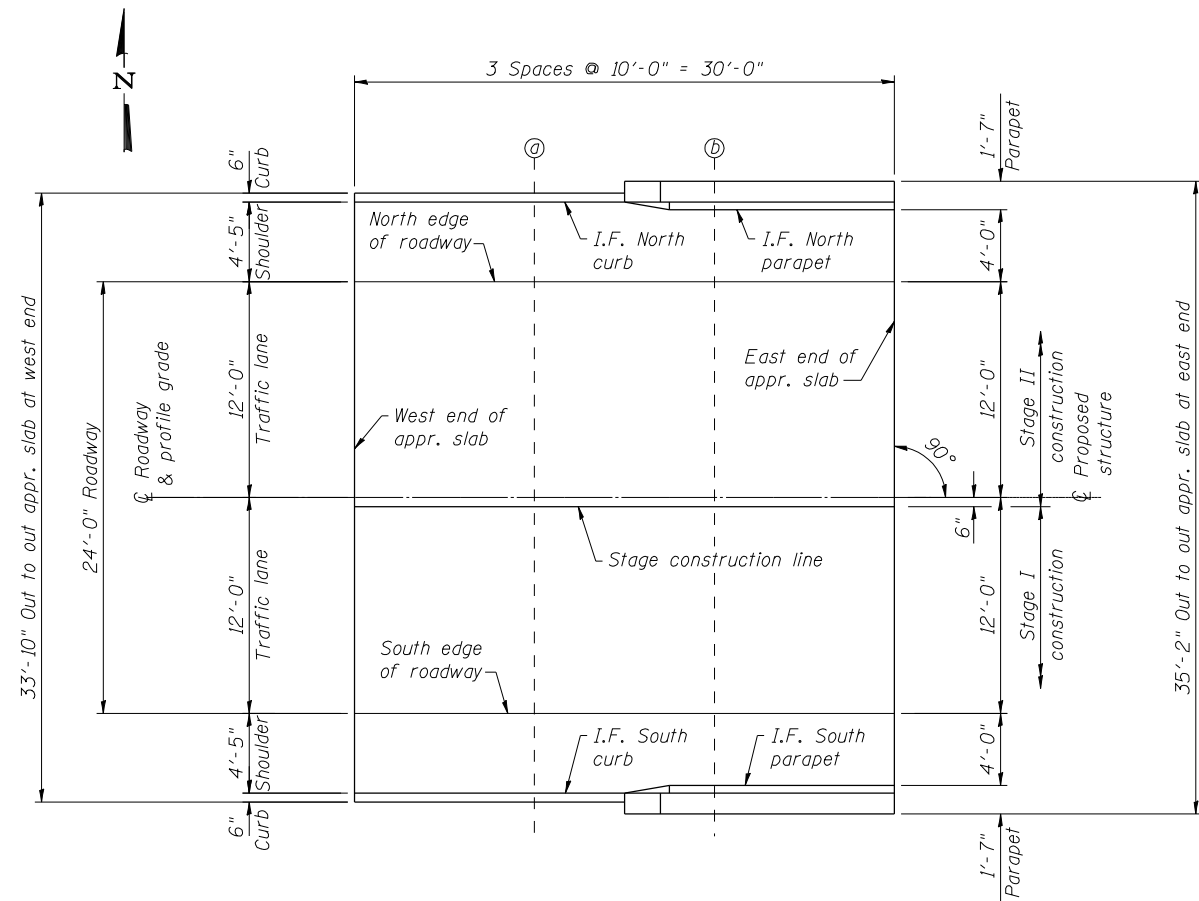

PLAN

INSIDE FACE OF NORTH CURB/PARAPET

Location	Station	Offset	Theoretical Grade Elevations
W. end appr. slab	912+70.50	-16.42	353.37
a	912+80.50	-16.42	353.41
b	912+90.50	-16.00	353.46
E. end appr. Slab	913+00.50	-16.00	353.50

STAGE CONSTRUCTION LINE

Location	Station	Offset	Theoretical Grade Elevations
W. end appr. slab	912+70.50	0.50	353.64
a	912+80.50	0.50	353.68
b	912+90.50	0.50	353.72
E. end appr. Slab	913+00.50	0.50	353.76

NORTH EDGE OF ROADWAY

Location	Station	Offset	Theoretical Grade Elevations
W. end appr. slab	912+70.50	-12.00	353.46
a	912+80.50	-12.00	353.50
b	912+90.50	-12.00	353.54
E. end appr. Slab	913+00.50	-12.00	353.58

SOUTH EDGE OF ROADWAY

Location	Station	Offset	Theoretical Grade Elevations
W. end appr. slab	912+70.50	12.00	353.46
a	912+80.50	12.00	353.50
b	912+90.50	12.00	353.54
E. end appr. Slab	913+00.50	12.00	353.58

ROADWAY & PROFILE GRADE

Location	Station	Offset	Theoretical Grade Elevations
W. end appr. slab	912+70.50	0.00	353.65
a	912+80.50	0.00	353.69
b	912+90.50	0.00	353.73
E. end appr. Slab	913+00.50	0.00	353.77

INSIDE FACE OF SOUTH CURB/PARAPET

Location	Station	Offset	Theoretical Grade Elevations
W. end appr. slab	912+70.50	16.42	353.37
a	912+80.50	16.42	353.41
b	912+90.50	16.00	353.46
E. end appr. Slab	913+00.50	16.00	353.50

PRINT DRIVER = L:\05-10-2013  
SCALE NAME = 8/2 1/4" = 1'-0"  
FILE NAME = 8/2/2013 11:36:43 AM



USER NAME = has	DESIGNED - SHL 12/12	REVISED -
ESCA PROJECT NO. 988.12	CHECKED - RDP 03/13	REVISED -
PLOT SCALE = 8/2 1/4" = 1'-0"	DRAWN - HAS 12/12	REVISED -
PLOT DATE = 8/2/2013 11:36:43 AM	CHECKED - RDP 03/13	REVISED -

STATE OF ILLINOIS  
DEPARTMENT OF TRANSPORTATION

TOP OF WEST APPROACH SLAB ELEVATIONS  
STRUCTURE NO. 076-0032

SHEET NO. 6 OF 21 SHEETS

F.A.P. RTE.	SECTION	COUNTY	TOTAL SHEETS	SHEET NO.
885	112B-1	POPE	56	28
CONTRACT NO. 78230			ILLINOIS FED. AID PROJECT AID	

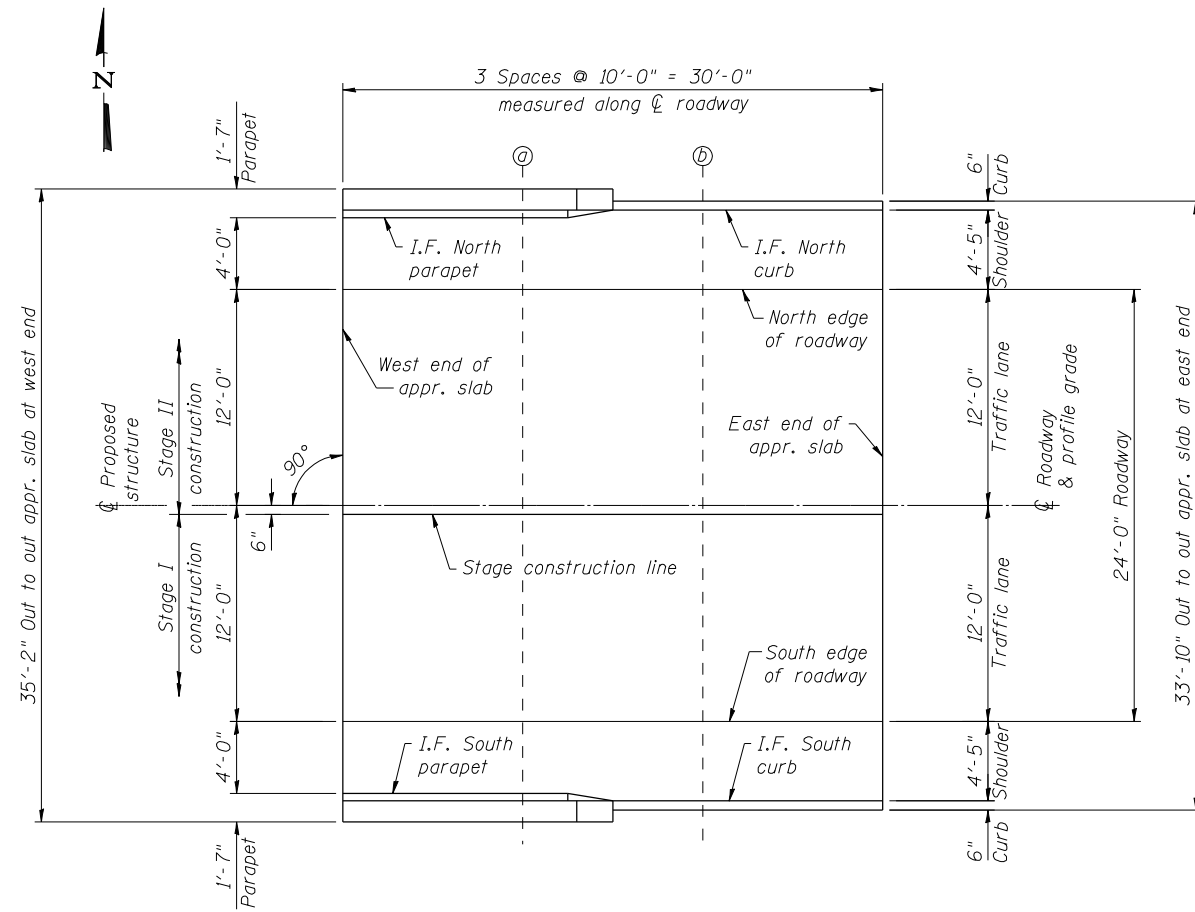

PLAN

INSIDE FACE OF NORTH CURB/PARAPET

Location	Station	Offset	Theoretical Grade Elevations
W. end appr. slab	913+99.50	-16.00	353.50
a	914+09.50	-16.00	353.46
b	914+19.50	-16.42	353.41
E. end appr. Slab	914+29.50	-16.42	353.37

STAGE CONSTRUCTION LINE

Location	Station	Offset	Theoretical Grade Elevations
W. end appr. slab	913+99.50	0.50	353.76
a	914+09.50	0.50	353.72
b	914+19.50	0.50	353.68
E. end appr. Slab	914+29.50	0.50	353.64

NORTH EDGE OF ROADWAY

Location	Station	Offset	Theoretical Grade Elevations
W. end appr. slab	913+99.50	-12.00	353.58
a	914+09.50	-12.00	353.54
b	914+19.50	-12.00	353.50
E. end appr. Slab	914+29.50	-12.00	353.46

SOUTH EDGE OF ROADWAY

Location	Station	Offset	Theoretical Grade Elevations
W. end appr. slab	913+99.50	12.00	353.58
a	914+09.50	12.00	353.54
b	914+19.50	12.00	353.50
E. end appr. Slab	914+29.50	12.00	353.46

ROADWAY & PROFILE GRADE

Location	Station	Offset	Theoretical Grade Elevations
W. end appr. slab	913+99.50	0.00	353.77
a	914+09.50	0.00	353.73
b	914+19.50	0.00	353.69
E. end appr. Slab	914+29.50	0.00	353.65

INSIDE FACE OF SOUTH CURB/PARAPET

Location	Station	Offset	Theoretical Grade Elevations
W. end appr. slab	913+99.50	16.00	353.50
a	914+09.50	16.00	353.46
b	914+19.50	16.42	353.41
E. end appr. Slab	914+29.50	16.42	353.37

PRINT DRIVER = L:\05-ESCA\0111  
 SCALE NAME = PLOT  
 FILE NAME = 076-0032-78230-07-TECH-01.dwg



USER NAME = has	DESIGNED - SHL 12/12	REVISED -
ESCA PROJECT NO. 988.12	CHECKED - RDP 03/13	REVISED -
PLOT SCALE = 0/2" = 1" / IN.	DRAWN - HAS 12/12	REVISED -
PLOT DATE = 8/2/2013 11:37:03 AM	CHECKED - RDP 03/13	REVISED -

STATE OF ILLINOIS  
 DEPARTMENT OF TRANSPORTATION

TOP OF EAST APPROACH SLAB ELEVATIONS  
 STRUCTURE NO. 076-0032

SHEET NO. 7 OF 21 SHEETS

F.A.P. RTE.	SECTION	COUNTY	TOTAL SHEETS	SHEET NO.
885	112B-1	POPE	56	29
CONTRACT NO. 78230			ILLINOIS FED. AID PROJECT AID	

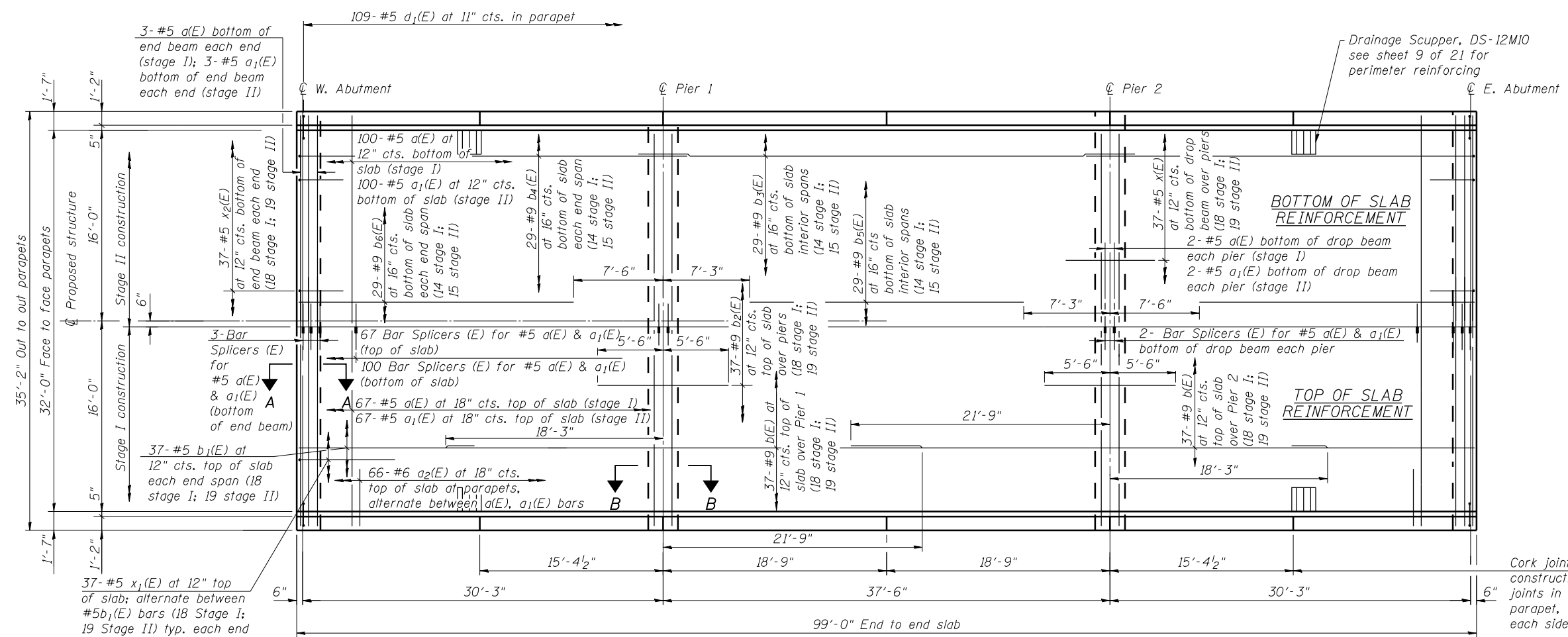

Notes:  
See sheets 9 and 10 of 21 for Bill of Material and parapet details.  
See sheet 10 of 21 for sections.

**MINIMUM BAR LAP**  
(Slab)

- #5 bar = 2'-3"
- #9 bar = 5'-11" (top)
- #9 bar = 5'-3" (bottom)

Cork joint filler construction joints in top of parapet, typ. each side

**PLAN**

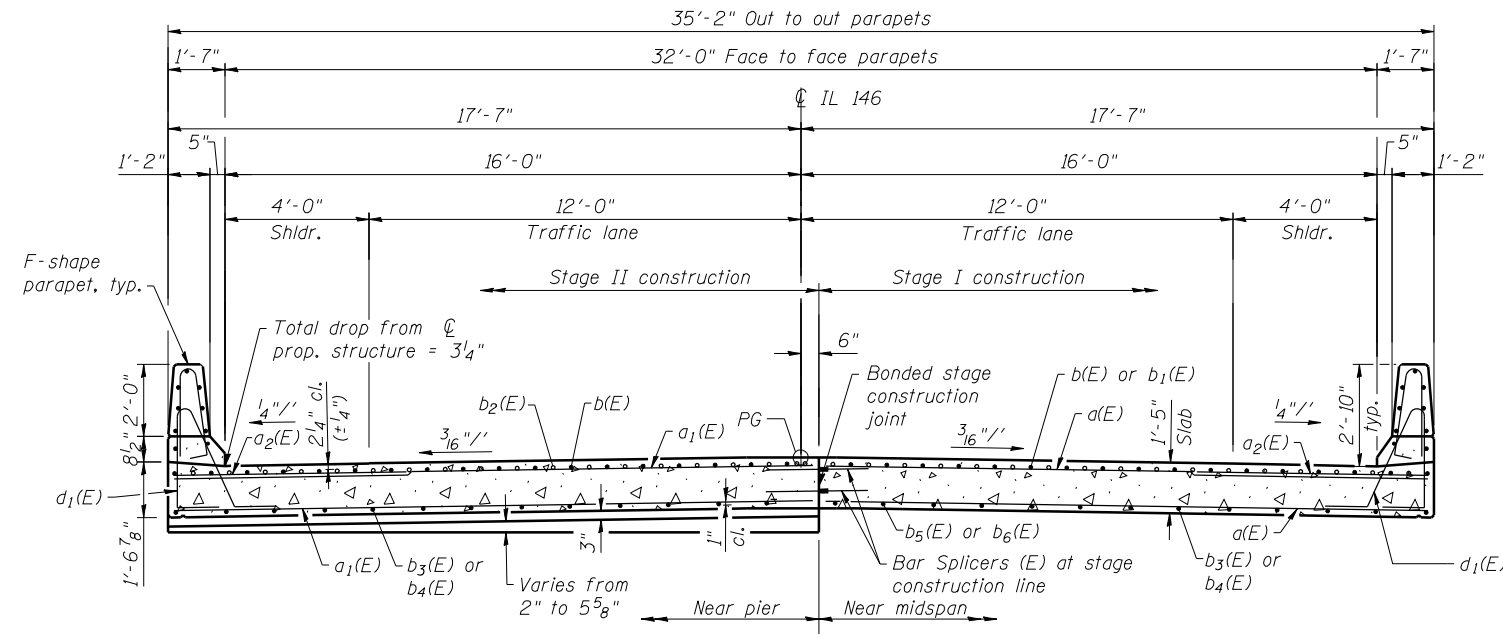

**CROSS SECTION**  
(Looking East)



USER NAME = has	DESIGNED - SHL 12/12	REVISED -
ESCA PROJECT NO. 988.12	CHECKED - RDP 03/13	REVISED -
PLOT SCALE = 1/8" = 1' / IN.	DRAWN - HAS 12/12	REVISED -
PLOT DATE = 8/2/2013 11:37:24 AM	CHECKED - RDP 06/13	REVISED -

**STATE OF ILLINOIS**  
**DEPARTMENT OF TRANSPORTATION**

**SUPERSTRUCTURE**  
**STRUCTURE NO. 076-0032**

SHEET NO. 8 OF 21 SHEETS

F.A.P. RTE. 885	SECTION 112B-1	COUNTY POPE	TOTAL SHEETS 56	SHEET NO. 30
CONTRACT NO. 78230			ILLINOIS FED. AID PROJECT AID	

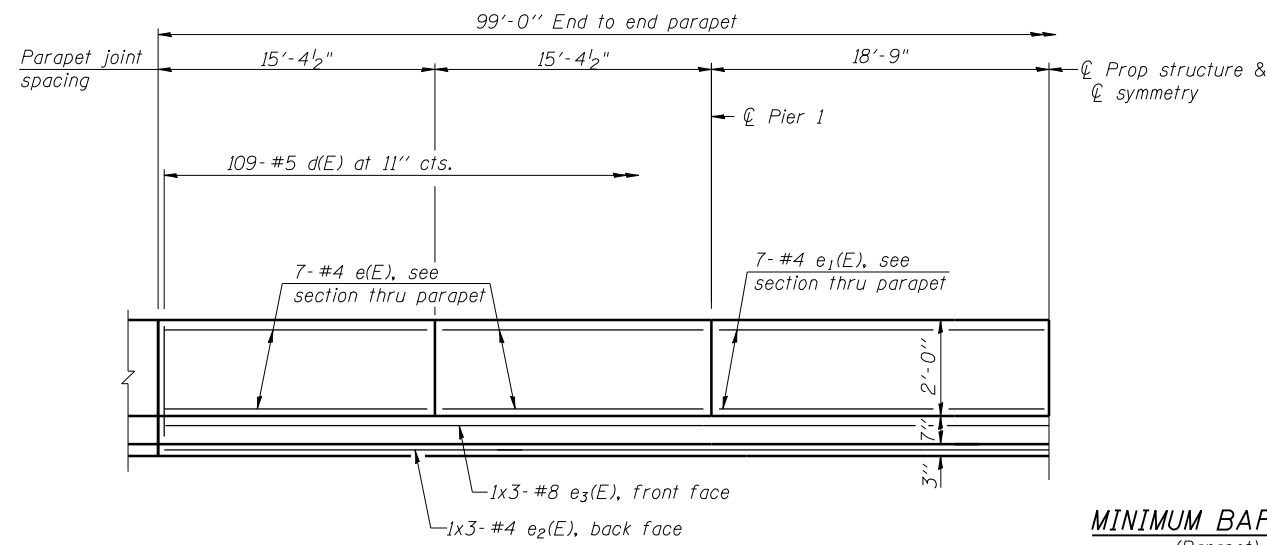

**INSIDE ELEVATION OF PARAPET**

**MINIMUM BAR LAP**  
 (Parapet)  
 #4 bar = 2'-0"  
 #8 bar = 5'-2"

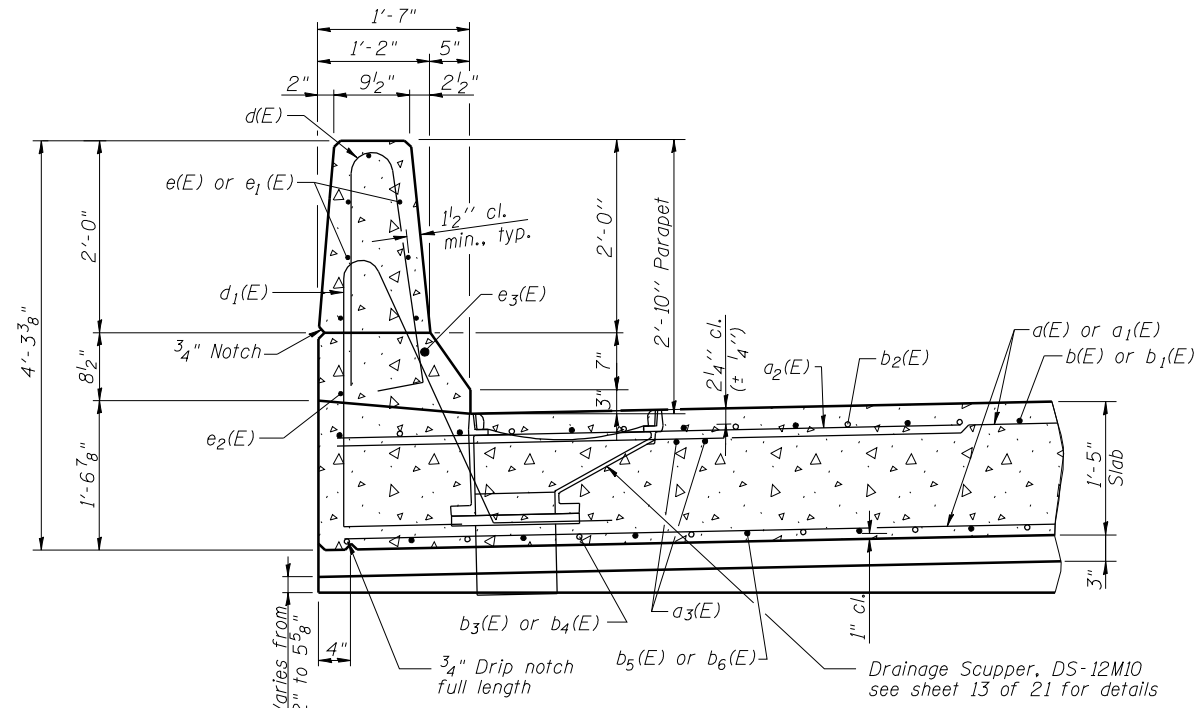

**SECTION THRU PARAPET**

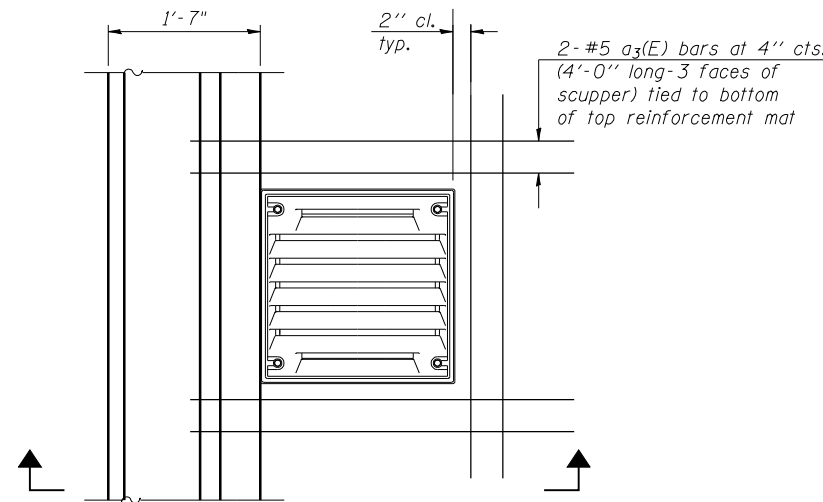

**SCUPPER REINFORCING PLAN**

Note:  
 Cut longitudinal reinforcement to clear drainage scuppers.

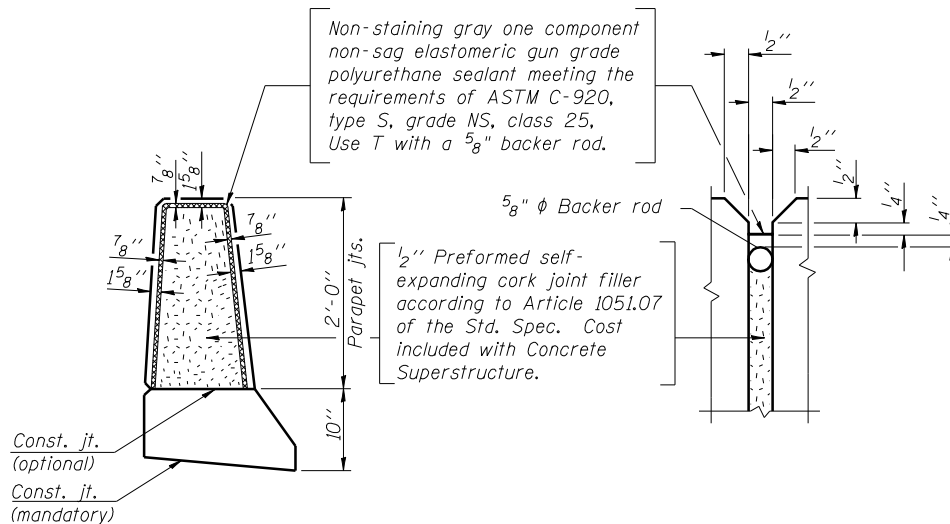

**PARAPET JOINT DETAILS**

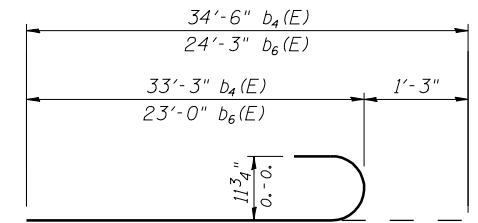

**BARS b<sub>4</sub>(E) & b<sub>6</sub>(E)**

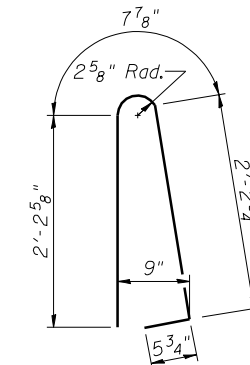

**BAR d(E)**

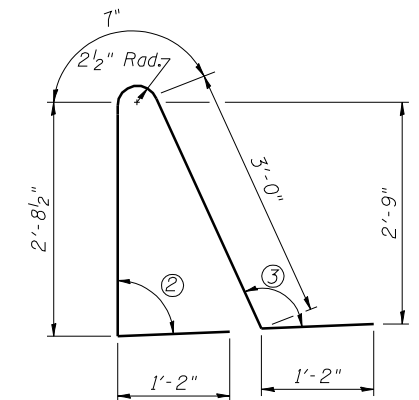

**BAR d<sub>1</sub>(E)**

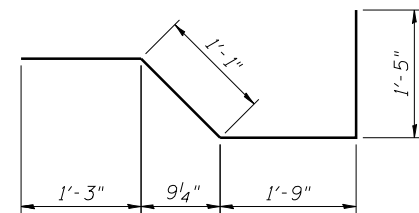

**BAR x<sub>2</sub>(E)**

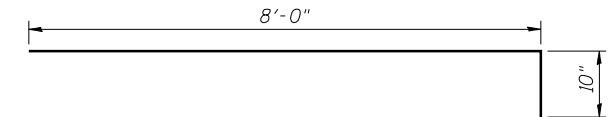

**BAR x<sub>1</sub>(E)**

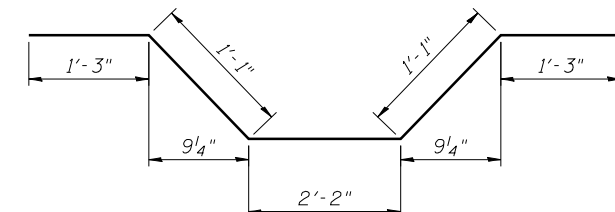

**BAR x(E)**

PRINT DRIVER = L:\05-EB\0411  
 SCALE NAME = PLOT  
 FILE NAME = 076-0032-78230-SP-01.dwg



USER NAME = has	DESIGNED - SHL 12/12	REVISED -
ESCA PROJECT NO. 988.12	CHECKED - RDP 03/13	REVISED -
PLOT SCALE = 0/2" = 1" / IN.	DRAWN - HAS 12/12	REVISED -
PLOT DATE = 8/2/2013 11:37:47 AM	CHECKED - RDP 06/13	REVISED -

**STATE OF ILLINOIS  
 DEPARTMENT OF TRANSPORTATION**

**SUPERSTRUCTURE DETAILS  
 STRUCTURE NO. 076-0032**

SHEET NO. 9 OF 21 SHEETS

F.A.P. RTE.	SECTION	COUNTY	TOTAL SHEETS	SHEET NO.
885	112B-1	POPE	56	31
CONTRACT NO. 78230				
ILLINOIS FED. AID PROJECT AID				

**SUPERSTRUCTURE  
BILL OF MATERIAL**

Bar	No.	Size	Length	Shape
a(E)	177	#5	16'-10"	—
a <sub>1</sub> (E)	177	#5	17'-10"	—
a <sub>2</sub> (E)	132	#6	6'-6"	—
a <sub>3</sub> (E)	24	#5	4'-0"	—
b(E)	74	#9	40'-0"	—
b <sub>1</sub> (E)	74	#5	14'-10"	—
b <sub>2</sub> (E)	74	#9	11'-0"	—
b <sub>3</sub> (E)	29	#9	42'-9"	—
b <sub>4</sub> (E)	58	#9	34'-6"	—
b <sub>5</sub> (E)	29	#9	23'-0"	—
b <sub>6</sub> (E)	58	#9	24'-3"	—
d(E)	218	#5	5'-7"	⌋
d <sub>1</sub> (E)	218	#5	8'-8"	⌋
e(E)	56	#4	15'-2"	—
e <sub>1</sub> (E)	28	#4	18'-6"	—
e <sub>2</sub> (E)	6	#4	34'-3"	—
e <sub>3</sub> (E)	6	#8	36'-4"	—
x(E)	74	#5	6'-10"	—
x <sub>1</sub> (E)	74	#5	8'-10"	—
x <sub>2</sub> (E)	74	#5	5'-6"	—
Reinforcement Bars, Epoxy Coated	Pound		46,340	
Concrete Superstructure	Cu. Yd.		212.4	
Bar Splicers	Each		177	

For details of Bar Splicers, see sheet 19 of 21.  
Name Plate to be mounted on inside face of parapet, see sheet 1 of 21.  
See sheet 9 of 21 for bar bending details.

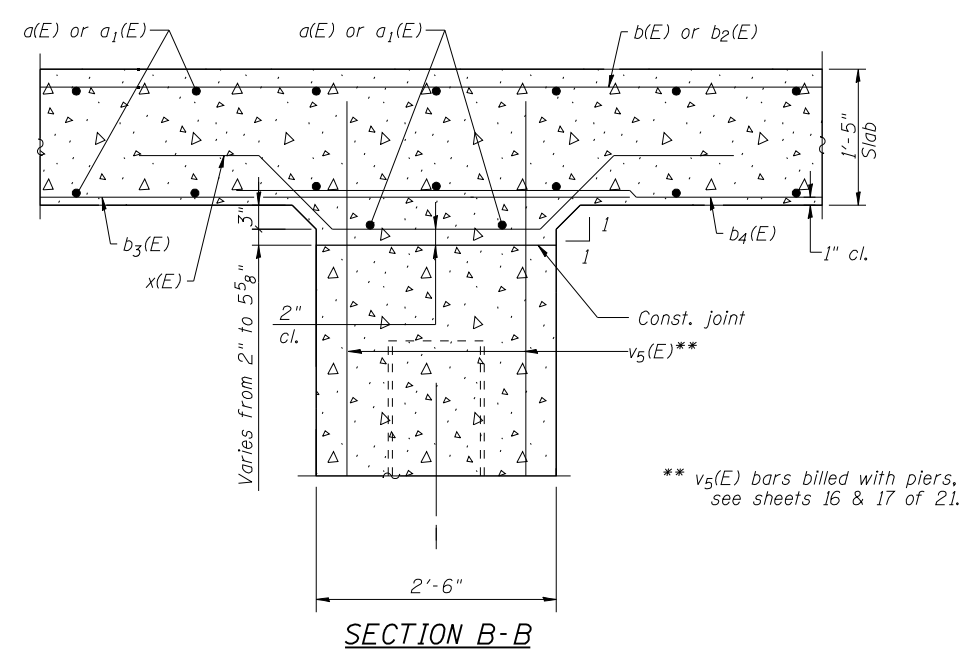
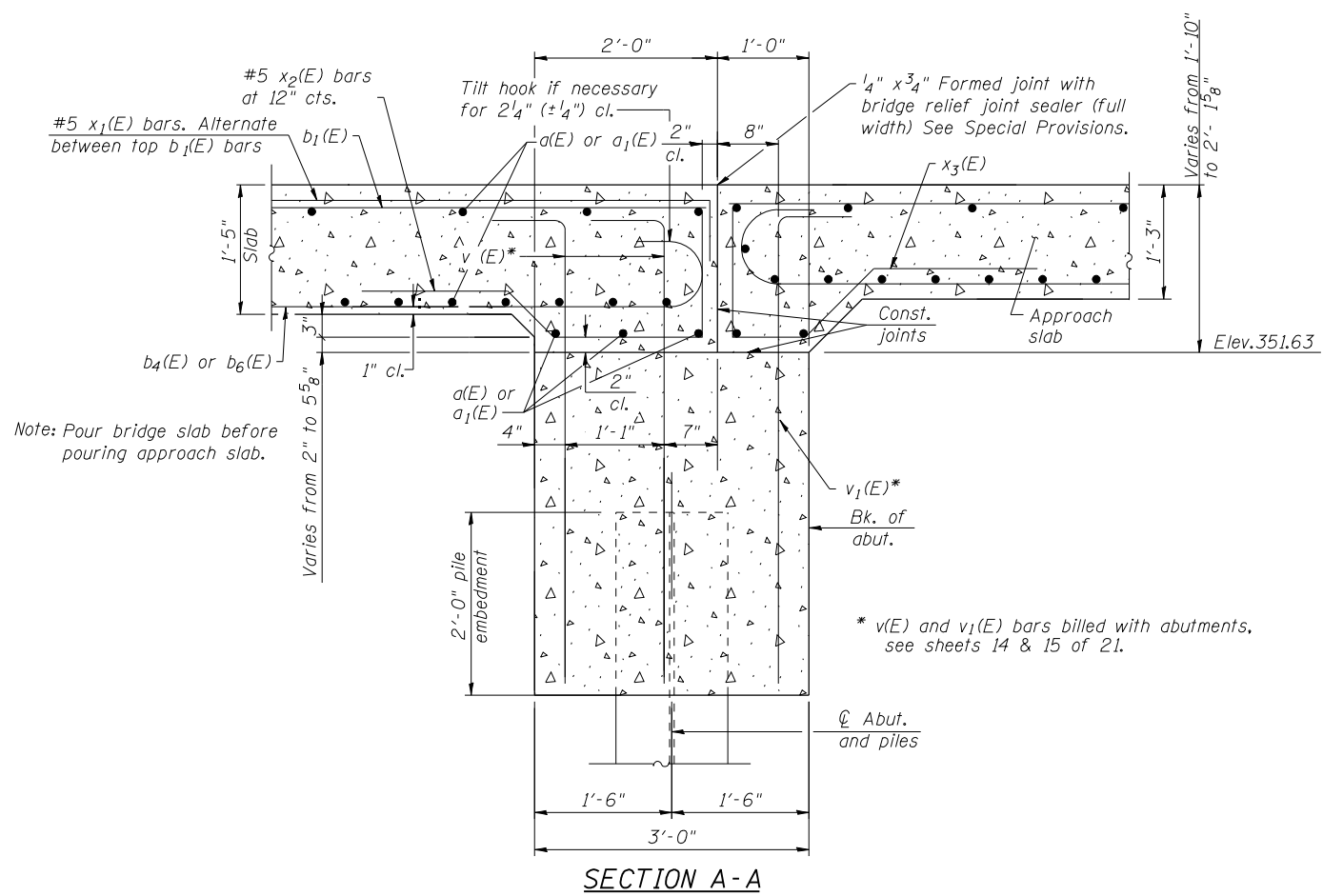

PRINT DRIVER = LUD-EBR-041L  
 LUD-EBR-041L  
 MAKE NAME =  
 FILE NAME = 8/2/2013 11:38:07 AM



USER NAME = has	DESIGNED - SHL 12/12	REVISED -
ESCA PROJECT NO. 988.12	CHECKED - RDP 03/13	REVISED -
PLOT SCALE = 0.2" = 1' / IN.	DRAWN - HAS 12/12	REVISED -
PLOT DATE = 8/2/2013 11:38:07 AM	CHECKED - RDP 07/13	REVISED -

**STATE OF ILLINOIS  
DEPARTMENT OF TRANSPORTATION**

**SUPERSTRUCTURE DETAILS  
STRUCTURE NO. 076-0032**

SHEET NO. 10 OF 21 SHEETS

F.A.P. RTE.	SECTION	COUNTY	TOTAL SHEETS	SHEET NO.
885	112B-1	POPE	56	32
ILLINOIS FED. AID PROJECT AID			CONTRACT NO. 78230	



Notes:  
 See sheet 12 of 21 for Sections C-C & D-D and View E-E.  
 $a_4(E)$  and  $a_5(E)$ , and  $a_6(E)$  bar spacings measured along  $\bar{C}$  Rdwy.  
 The joint opening shall be determined per Article 520.04 except that on jointless structures, the distance described as the bridge length between the nearest fixed bearings each way from the joint shall be taken as half the bridge length plus the approach slab length. The minimum dimension shall be  $1\frac{1}{2}$ " for installation purposes.

\*\*\* Cost included with Concrete Superstructure.

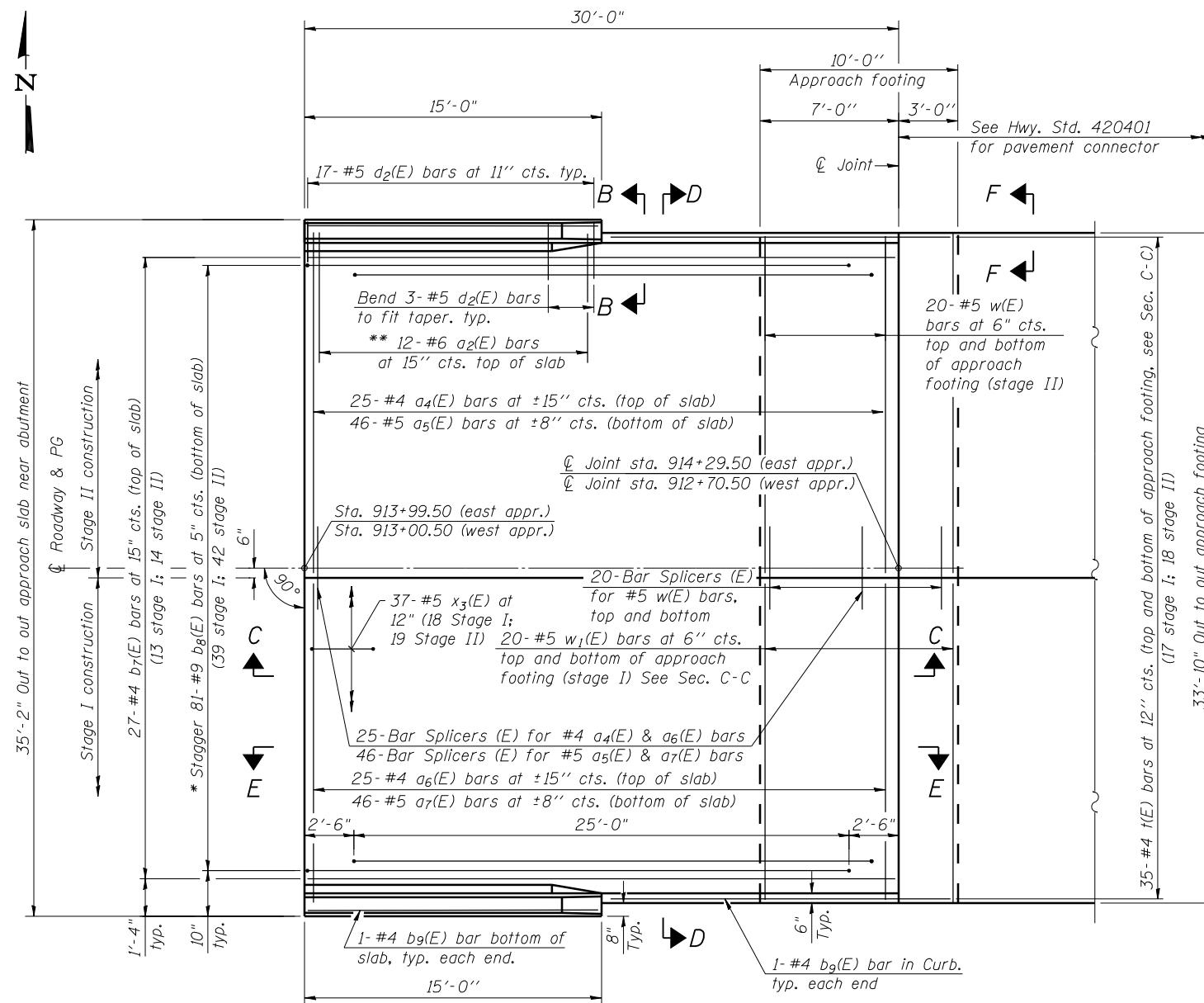

**PLAN**  
 (East approach slab shown; west approach slab similar)

\* Tilt #9  $b_8(E)$  bars as required to maintain clearance.  
 \*\* Space between  $a_4(E)$  and  $a_6(E)$  bars, typ. ea. parapet.

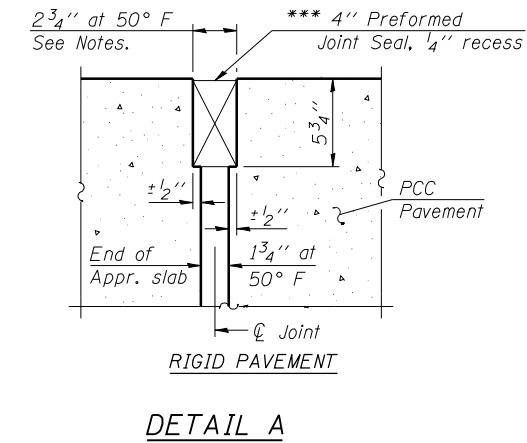

**DETAIL A**

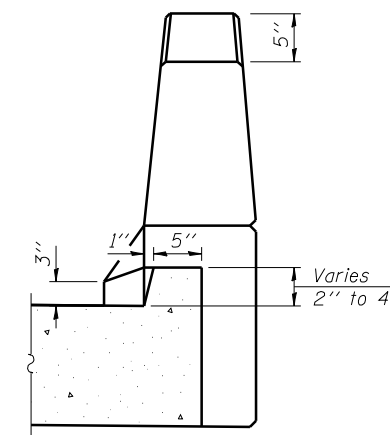
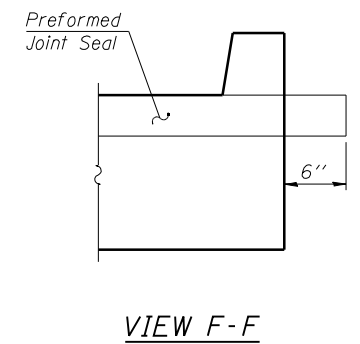
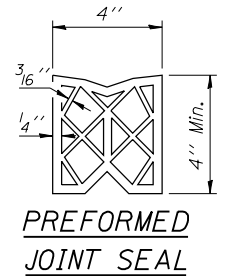

**VIEW B-B**

(Sheet 1 of 2)

PRINT DRIVER = L:\05-ESCA\PLT  
 SCALE NAME = PLOT  
 FILE NAME = 8/2/2013-78230-11-06-01.dwg



USER NAME = has	DESIGNED - SHL 12/12	REVISED -
ESCA PROJECT NO. 988.12	CHECKED - RDP 03/13	REVISED -
PLOT SCALE = 0/2' = 1/4" IN.	DRAWN - HAS 12/12	REVISED -
PLOT DATE = 8/2/2013 11:38:26 AM	CHECKED - RDP 07/13	REVISED -

**STATE OF ILLINOIS  
 DEPARTMENT OF TRANSPORTATION**

**BRIDGE APPROACH SLAB DETAILS  
 STRUCTURE NO. 076-0032**

SHEET NO. 11 OF 21 SHEETS

F.A.P. RTE.	SECTION	COUNTY	TOTAL SHEETS	SHEET NO.
885	112B-1	POPE	56	33
CONTRACT NO. 78230				

ILLINOIS FED. AID PROJECT AID

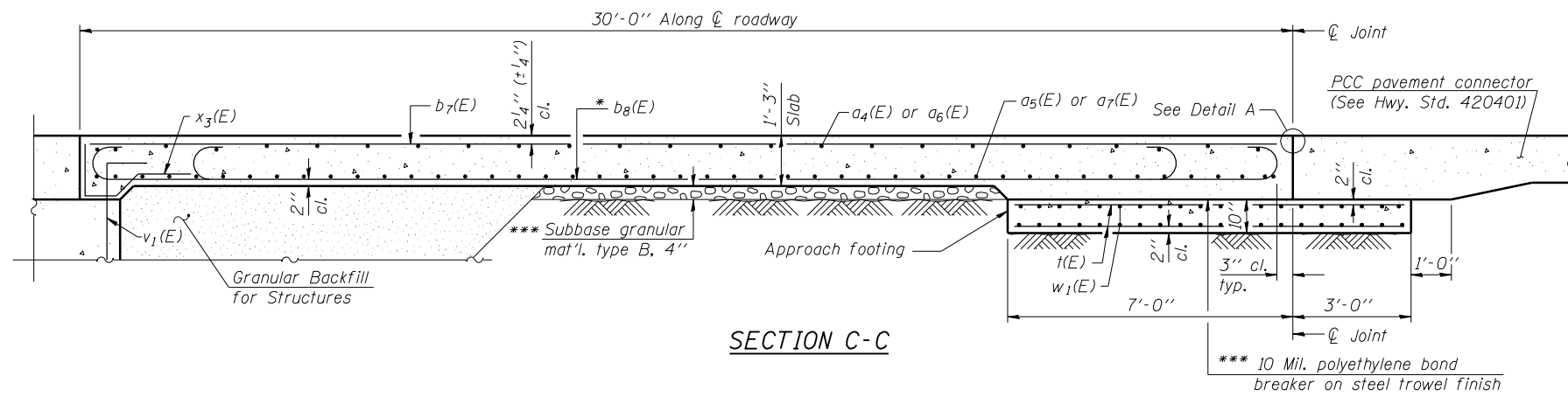

SECTION C-C

Notes:  
 See sheet 11 of 21 for Detail A and View B-B.  
 Approach slab and parapet concrete shall be paid for as Concrete Superstructure.  
 Approach footing concrete shall be paid for as Concrete Structures.  
 Reinforcement shall be paid for as Reinforcement Bars, Epoxy Coated.  
 For v1(E) bar details, see sheet 14 of 21.  
 The approach footing maximum applied service bearing pressure (Qmax) = 2.0 ksf.  
 For bar splicer details, see sheet 19 of 21.  
 Cost of excavation for approach footing included with Concrete Structures.  
 For Granular Backfill for Structures and drainage treatment details, see sheet 2 of 21.  
 For additional parapet details, see sheet 9 of 21.

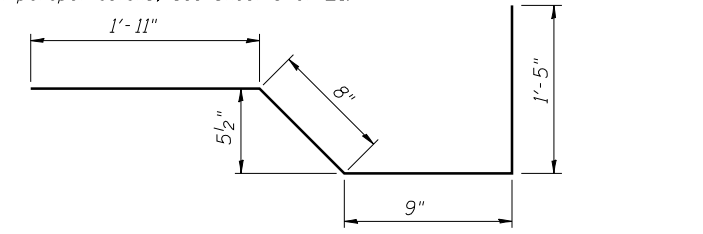

BAR x3(E)

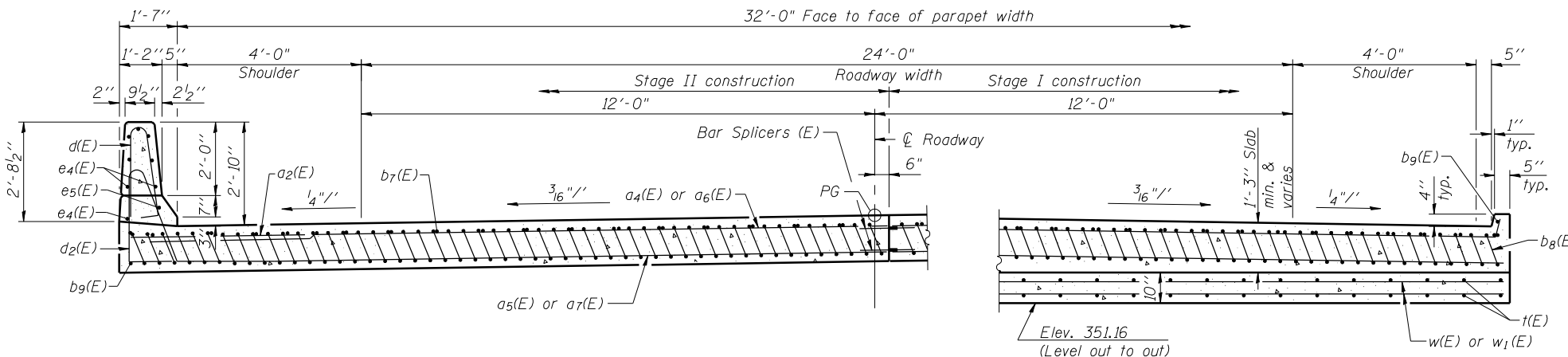

NEAR ABUTMENT

SECTION D-D

(See Plan for dimensions not shown)

AT APPROACH FOOTING

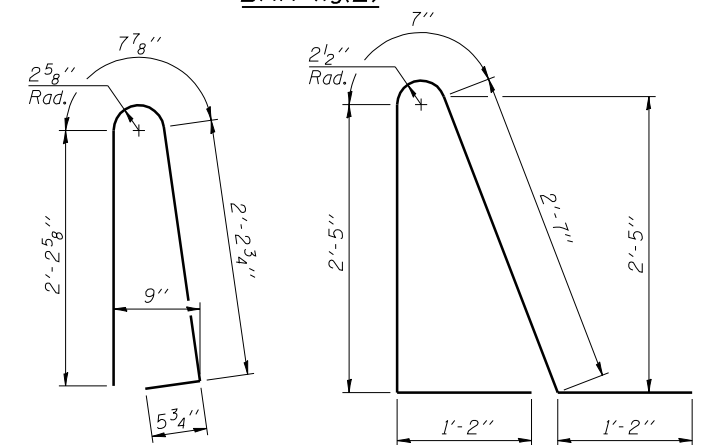

BAR d(E)

BAR d2(E)

\* Tilt #9 b8(E) bars as required to maintain clearance.

\*\*\* Cost included with Concrete Superstructure.

TWO APPROACHES  
 BILL OF MATERIAL

Bar	No.	Size	Length	Shape
a2(E)	48	#6	6'-6"	—
a4(E)	50	#4	17'-6"	—
a5(E)	92	#5	17'-2"	—
a6(E)	50	#4	16'-6"	—
a7(E)	92	#5	16'-2"	—
b7(E)	54	#4	29'-8"	—
b8(E)	162	#9	29'-9"	—
b9(E)	8	#4	14'-8"	—
d(E)	68	#5	5'-7"	—
d2(E)	68	#5	7'-11"	—
e4(E)	32	#4	14'-8"	—
e5(E)	4	#8	14'-8"	—
t(E)	140	#4	9'-8"	—
w(E)	80	#5	17'-2"	—
w1(E)	80	#5	16'-2"	—
x3(E)	74	#5	4'-9"	—
Concrete Superstructure		Cu. Yd.	109.3	
Concrete Structures		Cu. Yd.	20.9	
Reinforcement Bars, Epoxy Coated		Pound	27820	
Bar Splicers		Each	222	

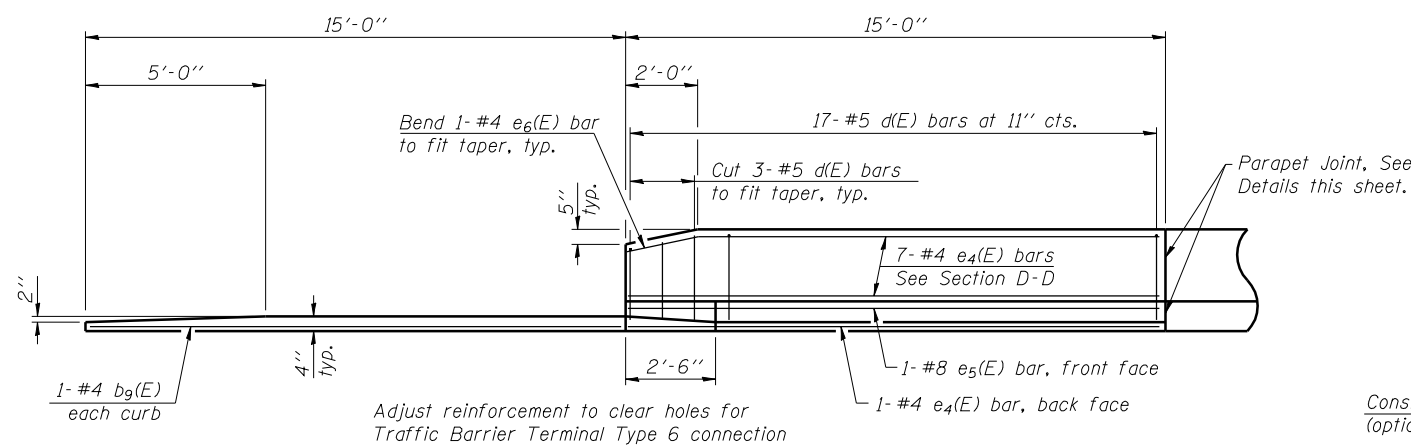

VIEW E-E

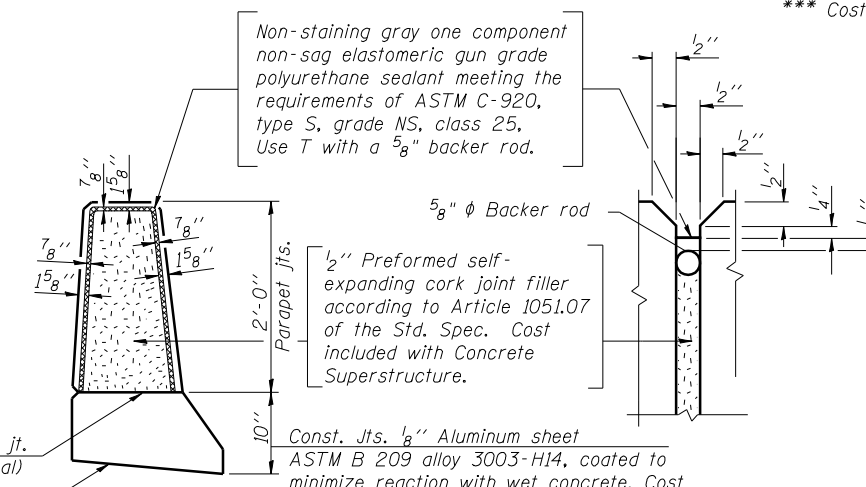

PARAPET JOINT DETAILS

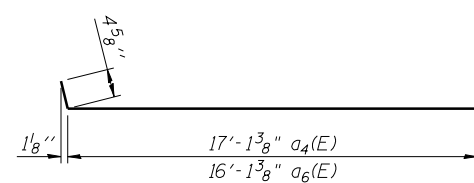

BARS a4(E) & a6(E)

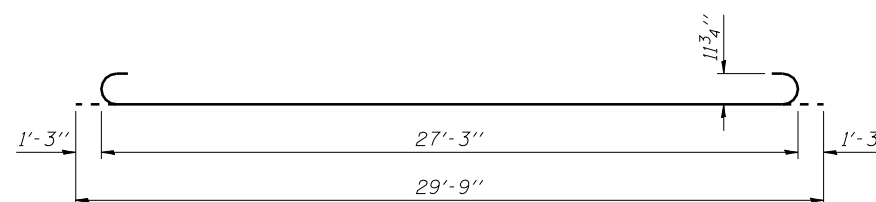

BAR b8(E)

(Sheet 2 of 2)

PRINT DRIVER = L:\05-ESCA\PLT  
 MAKE NAME = PLOT  
 FILE NAME = 076-0032-78230-12-Ap-01.dwg



USER NAME = has	DESIGNED - SHL 12/12	REVISED -
ESCA PROJECT NO. 988.12	CHECKED - RDP 03/13	REVISED -
PLOT SCALE = 0/2 ' / IN.	DRAWN - HAS 12/12	REVISED -
PLOT DATE = 8/2/2013 11:38:49 AM	CHECKED - RDP 06/13	REVISED -

STATE OF ILLINOIS  
 DEPARTMENT OF TRANSPORTATION

BRIDGE APPROACH SLAB DETAILS  
 STRUCTURE NO. 076-0032

SHEET NO. 12 OF 21 SHEETS

F.A.P. RTE.	SECTION	COUNTY	TOTAL SHEETS	SHEET NO.
885	112B-1	POPE	56	34
CONTRACT NO. 78230			ILLINOIS FED. AID PROJECT AID	

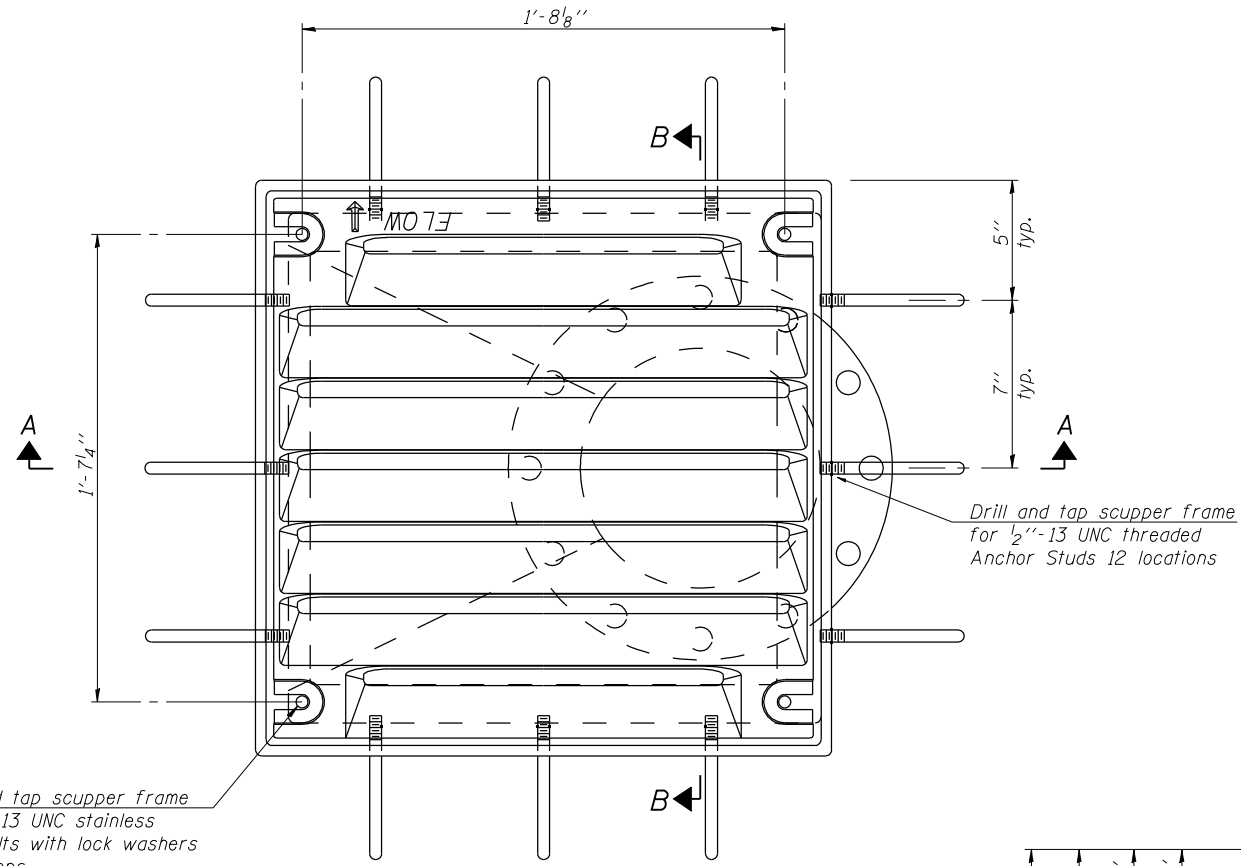

PLAN

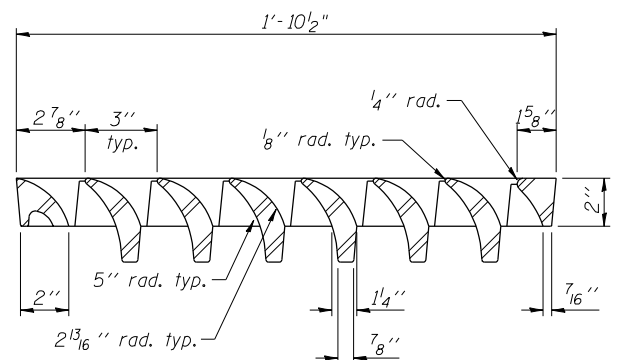

VANE GRATE DETAIL

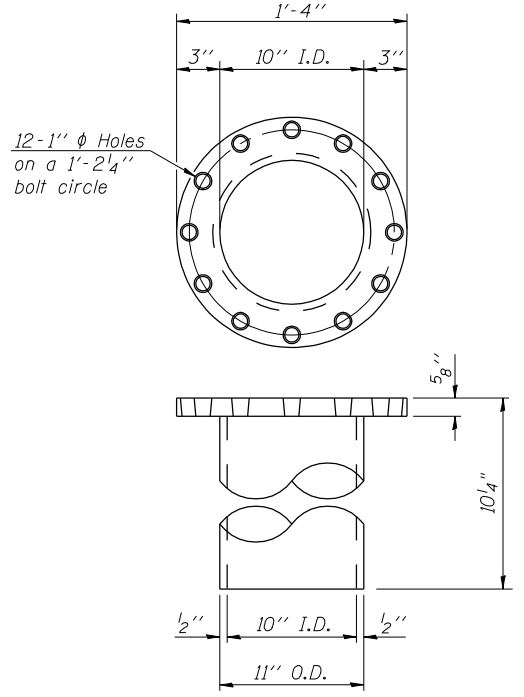

DOWNSPOUT

Drill and tap scupper frame for 1/2"-13 UNC stainless steel bolts with lock washers 4 locations

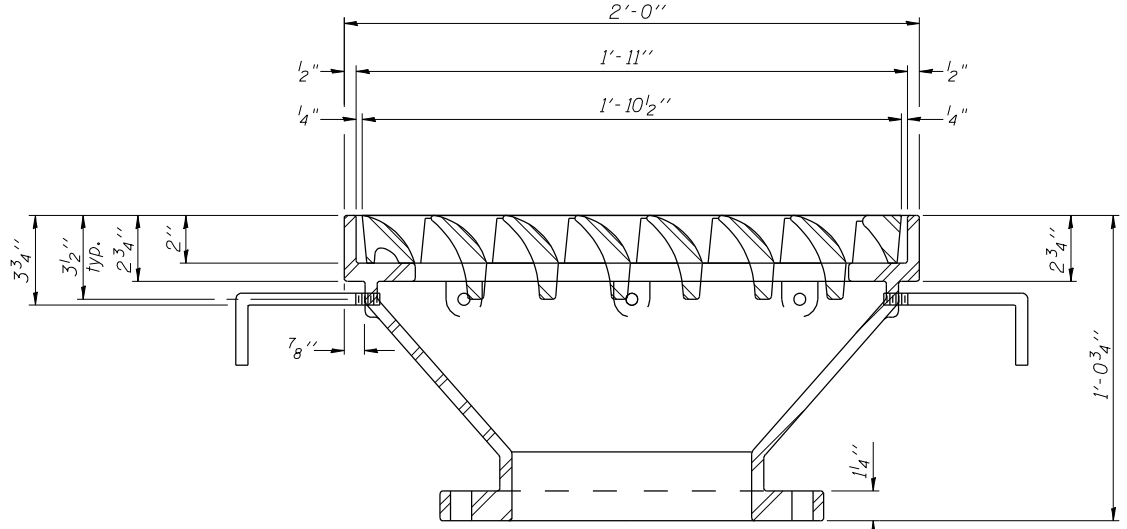

SECTION B-B

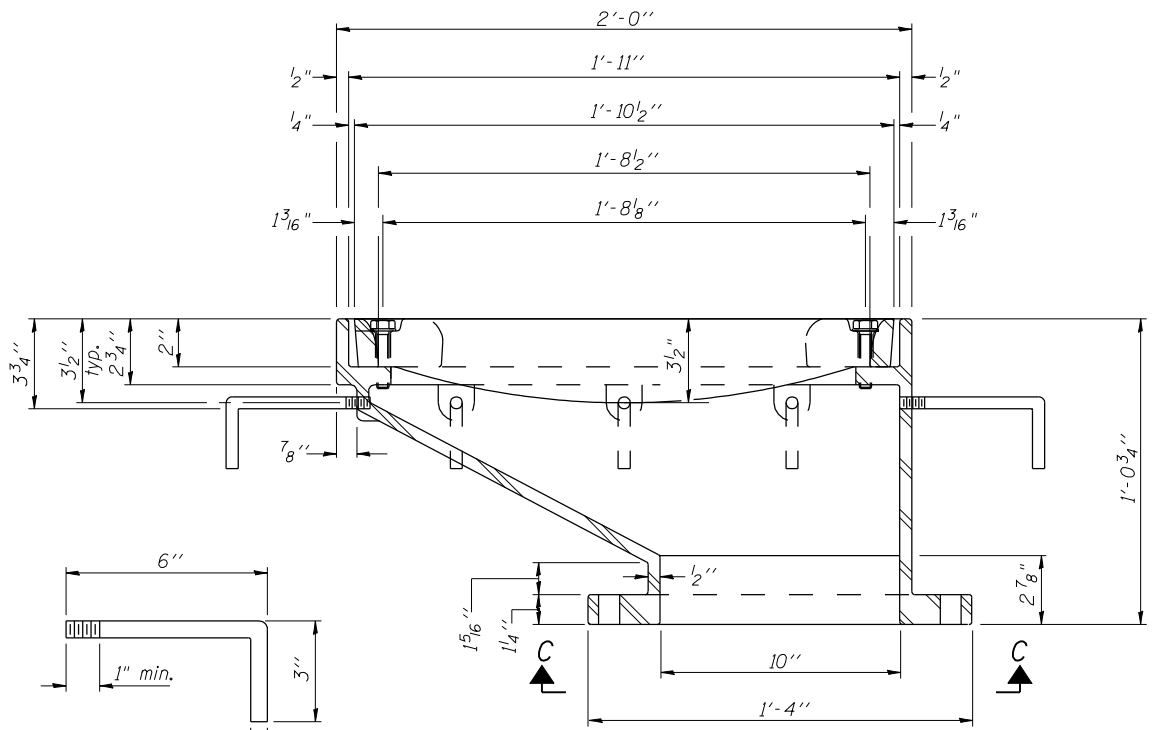

SECTION A-A

Drill and tap 12 holes for 7/8"-9 UNC bolts on 1'-2 1/4" bolt circle

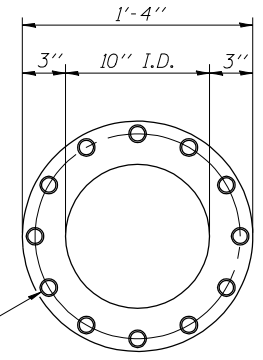

VIEW C-C

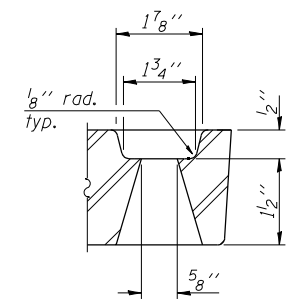

GRATE BOLT HOLE DETAIL

Notes:  
 All cast iron parts shall be gray iron conforming to the requirements of AASHTO M 105, Class 35B.  
 Bolts, anchor studs, washers and nuts shall conform to the requirements of ASTM A 307 and shall be galvanized according to AASHTO M 232.  
 All castings shall conform to the requirements of AASHTO M 306.  
 Downspouts located on the exterior side of a painted steel fascia beam shall be painted with the finish coat specified for the exterior side of the fascia beam.  
 As an alternate, bolts, anchor studs, washers and nuts may be stainless steel according to Article 1006.29(d) of the Standard Specifications.  
 Structural steel weldments of equal sections and of the same configuration may be substituted for the cast iron scupper frame. Fillet or full penetration welds shall be used for the weldments. Details shall be submitted to the Engineer for approval. Structural steel weldments shall not be substituted for the cast iron scupper grate. Structural steel frames and downspouts shall be galvanized according to AASHTO M111.  
 The Contractor shall take appropriate measures to assure that Protective Coat is not applied to the scupper.  
 Cost of the Grate, Frame, Downspout, Anchor Studs, Bolts, Washers and Nuts including complete installation of the scupper shall be paid for at the contract unit price each for Drainage Scupper, DS-12M10.  
 Alternate fiberglass downspout conforming to ASTM D 2996 with a short-time rupture strength hoop tensile stress of 30,000 psi min. may be used in lieu of the cast iron or steel equivalent.

BILL OF MATERIAL

ITEM	UNIT	QUANTITY
Drainage Scupper, DS-12M10	Each	4

ANCHOR STUD DETAIL

DS-12M10 7-1-10



USER NAME = has	DESIGNED - SHL 02/13	REVISED -
ESCA PROJECT NO. 988.12	CHECKED - RDP 03/13	REVISED -
PLOT SCALE = 1/8" = 1' / IN.	DRAWN - HAS 02/13	REVISED -
PLOT DATE = 8/2/2013 11:39:13 AM	CHECKED - RDP 03/13	REVISED -

STATE OF ILLINOIS  
DEPARTMENT OF TRANSPORTATION

DRAINAGE SCUPPER, DS-12M10  
STRUCTURE NO. 076-0032

SHEET NO. 13 OF 21 SHEETS

F.A.P. RTE. 885	SECTION 112B-1	COUNTY POPE	TOTAL SHEETS 56	SHEET NO. 35
CONTRACT NO. 78230			ILLINOIS FED. AID PROJECT AID	

PRINT DRIVER = LEO-EB@PAUL  
 PLOT SCALE = 1/8" = 1' / IN.  
 PLOT DATE = 8/2/2013 11:39:13 AM

**WEST ABUTMENT  
BILL OF MATERIAL**

Bar	No.	Size	Length	Shape
h(E)	12	#5	10'-6"	—
h <sub>1</sub> (E)	28	#4	8'-10"	—
p(E)	11	#7	16'-10"	—
p <sub>1</sub> (E)	11	#7	17'-10"	—
s(E)	25	#4	12'-9"	□
s <sub>1</sub> (E)	32	#4	3'-11"	┌
sp(E)	8	#4	2'-0"	W
u(E)	10	#5	9'-11"	□
v(E)	70	#5	5'-10"	┌
v <sub>1</sub> (E)	35	#5	6'-8"	┌
v <sub>2</sub> (E)	10	#5	8'-8"	—
v <sub>3</sub> (E)	12	#5	5'-6"	—
Structure Excavation			Cu. Yd.	70
Concrete Structures			Cu. Yd.	17.3
Reinforcement Bars, Epoxy Coated			Pound	2680
Furnishing Steel Piles, HP14x89			Foot	504
Driving Piles			Foot	504
Granular Backfill for Structures			Cu. Yd.	33
Geocomposite Wall Drain			Sq. Yd.	22
Pipe Underdrains for Structures, 4"			Foot	63
Bar Splicers			Each	11

\* Length is height of spiral.

For details of piles, see sheet 18 of 21.  
For details of Bar Splicers, see sheet 19 of 21.

**PILE DATA**

Type: Steel HP14x89  
Nominal Required Bearing: 705 kips  
Factored Resistance Available: 388 kips  
Estimated Length: 63'  
No. of Production Piles: 8  
No. of Test Piles: 0

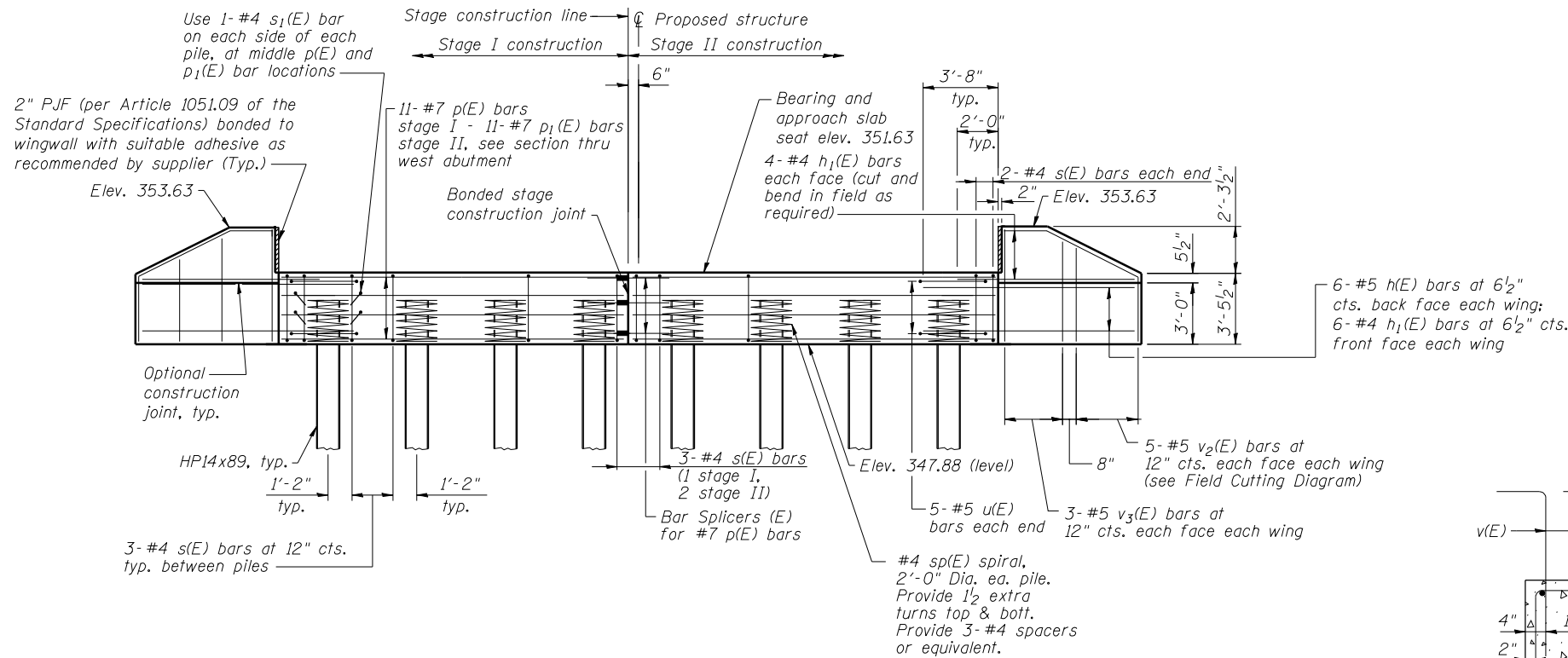

**ELEVATION**

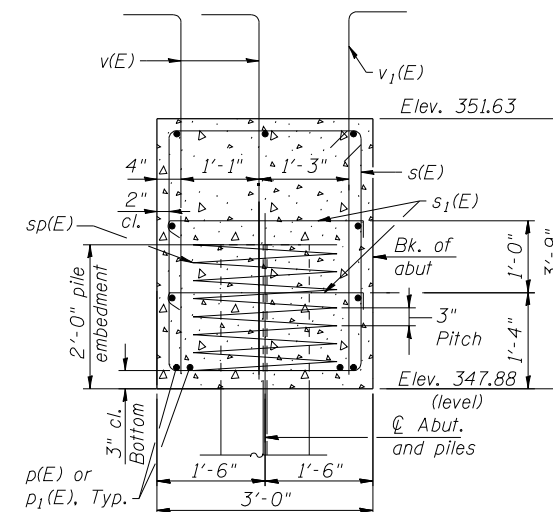

**SECTION THRU  
WEST ABUTMENT**

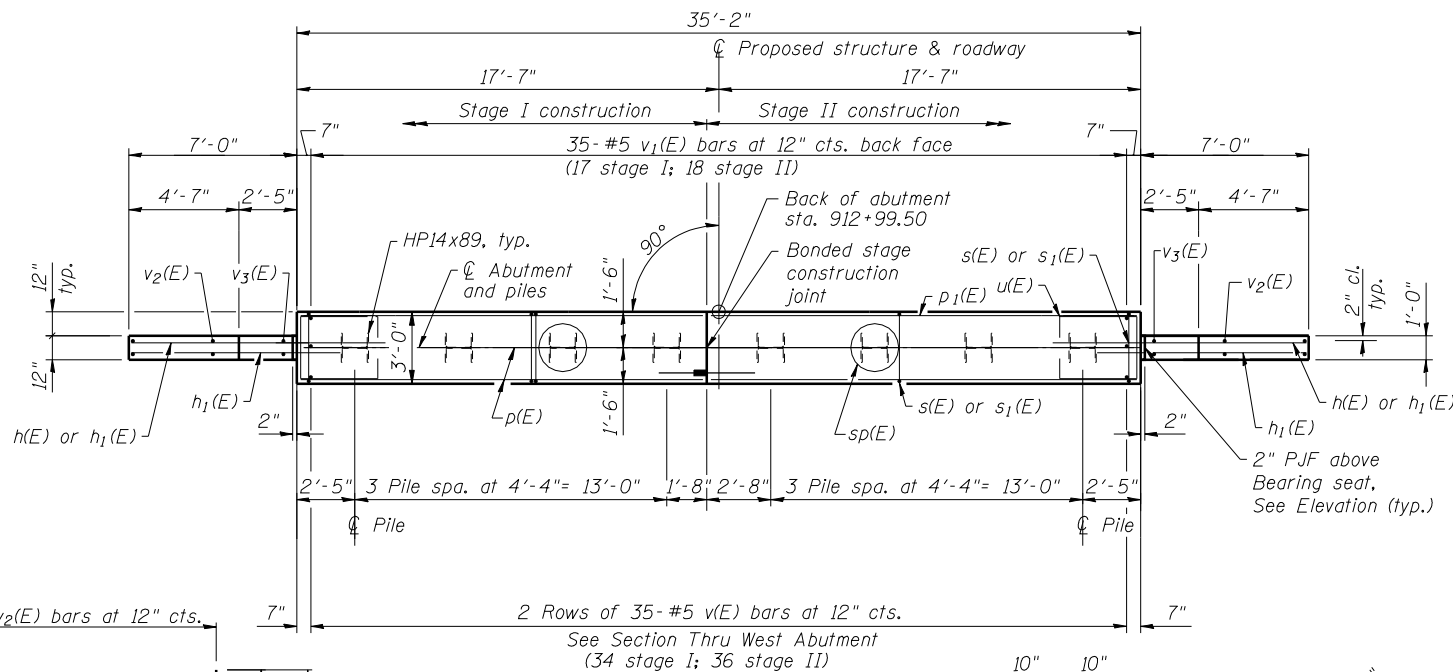

**PLAN**

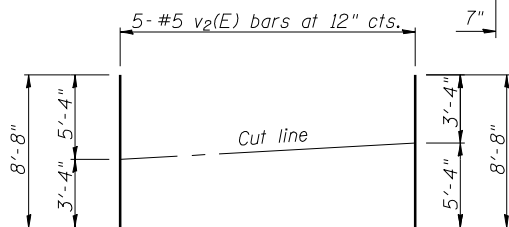

**BARS v<sub>2</sub>(E)**

**FIELD CUTTING DIAGRAM**

Order v<sub>2</sub>(E) full length.  
Cut as shown and use remainder of bars in opposite face.

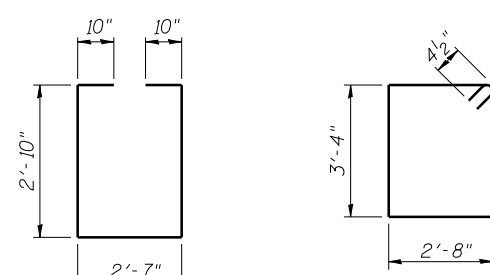

**BAR u(E)**

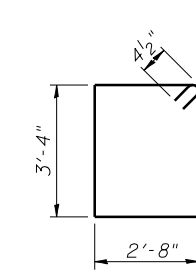

**BAR s(E)**

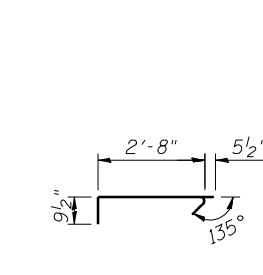

**BAR s<sub>1</sub>(E)**

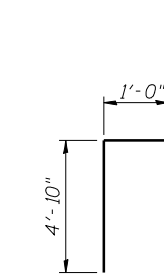

**BAR v(E)**

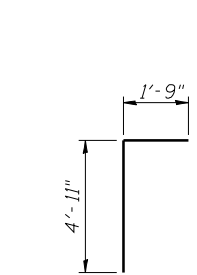

**BAR v<sub>1</sub>(E)**



USER NAME = has	DESIGNED - SHL 12/12	REVISED -
ESCA PROJECT NO. 988.12	CHECKED - RDP 03/13	REVISED -
PLOT SCALE = 1/2" = 1' / IN.	DRAWN - HAS 12/12	REVISED -
PLOT DATE = 8/2/2013 11:39:35 AM	CHECKED - RDP 07/13	REVISED -

**STATE OF ILLINOIS  
DEPARTMENT OF TRANSPORTATION**

**WEST ABUTMENT  
STRUCTURE NO. 076-0032**

SHEET NO. 14 OF 21 SHEETS

F.A.P. RTE.	SECTION	COUNTY	TOTAL SHEETS	SHEET NO.
885	112B-1	POPE	56	36
CONTRACT NO. 78230			ILLINOIS FED. AID PROJECT AID	

**EAST ABUTMENT  
BILL OF MATERIAL**

Bar	No.	Size	Length	Shape	
h(E)	12	#5	10'-6"	—	
h <sub>1</sub> (E)	28	#4	8'-10"	—	
p(E)	11	#7	16'-10"	—	
p <sub>1</sub> (E)	11	#7	17'-10"	—	
s(E)	25	#4	12'-9"	□	
s <sub>1</sub> (E)	32	#4	3'-11"	┌	
sp(E)	8	#4	2'-0"	MWWM	
u(E)	10	#5	9'-11"	□	
v(E)	70	#5	5'-10"	┌	
v <sub>1</sub> (E)	35	#5	6'-8"	┌	
v <sub>2</sub> (E)	10	#5	8'-8"	—	
v <sub>3</sub> (E)	12	#5	5'-6"	—	
Structure Excavation				Cu. Yd.	70
Concrete Structures				Cu. Yd.	17.3
Reinforcement Bars, Epoxy Coated				Pound	2680
Furnishing Steel Piles, HP14x89				Foot	488
Driving Piles				Foot	488
Granular Backfill for Structures				Cu. Yd.	33
Geocomposite Wall Drain				Sq. Yd.	22
Pipe Underdrains for Structures, 4"				Foot	63
Bar Splicers				Each	11

\*Length is height of spiral.

For details of piles, see sheet 18 of 21.

For details of Bar Splicers, see sheet 19 of 21.

For bar bending details, see sheet 14 of 21.

**PILE DATA**

Type: Steel HP14x89  
 Nominal Required Bearing: 705 kips  
 Factored Resistance Available: 388 kips  
 Estimated Length: 61'  
 No. of Production Piles: 8  
 No. of Test Piles: 0

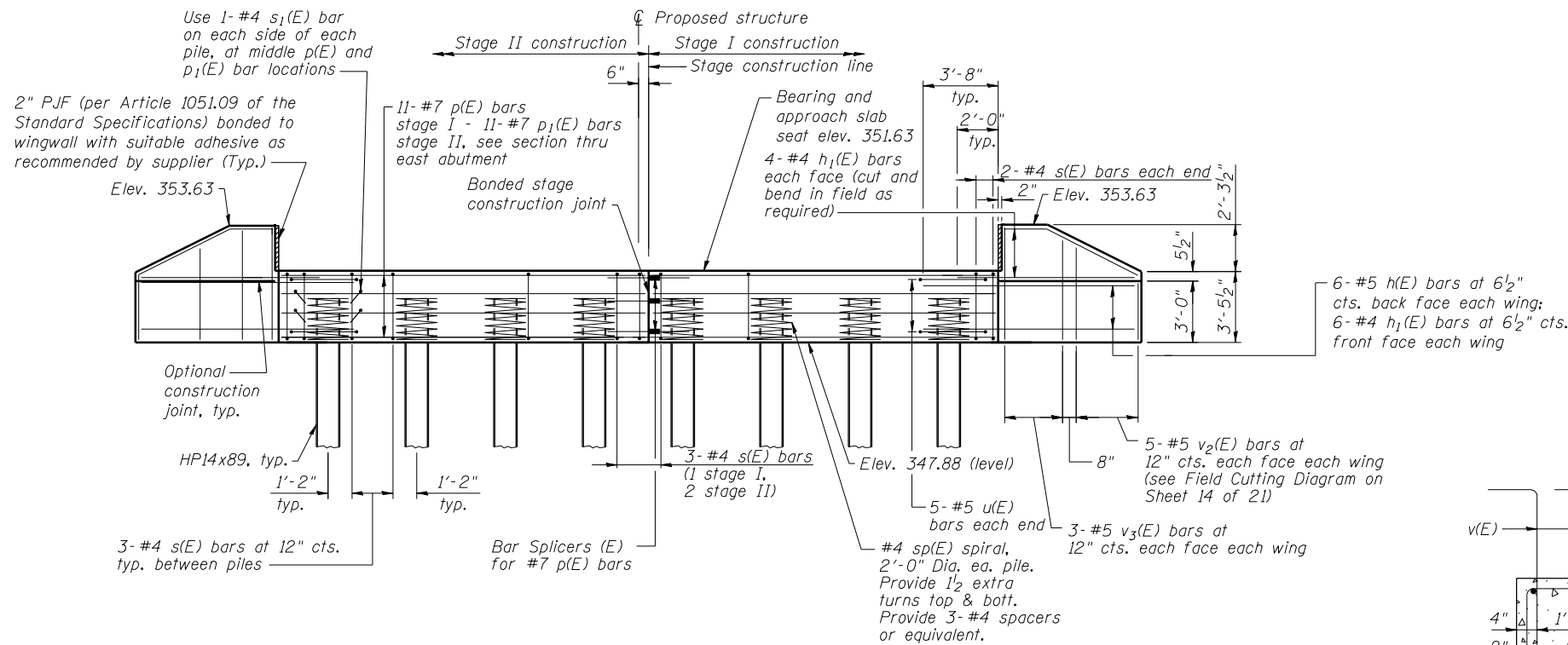

**ELEVATION**

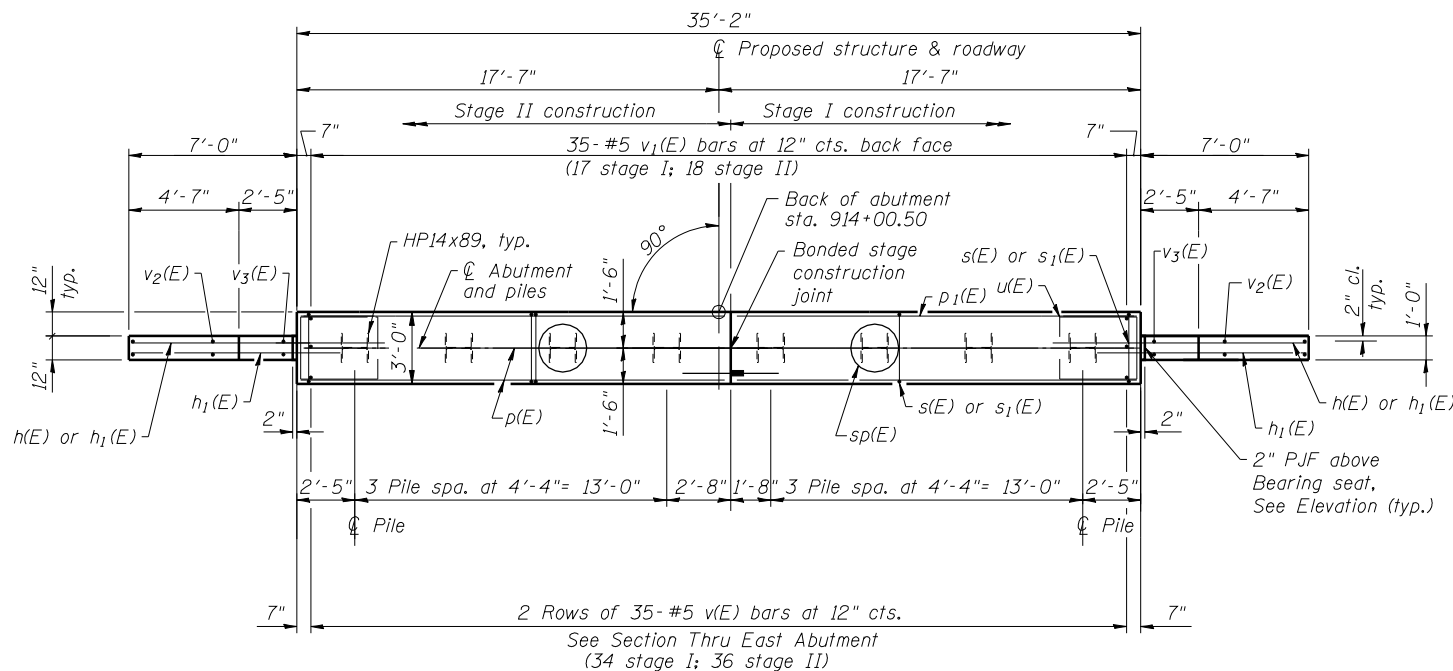

**PLAN**

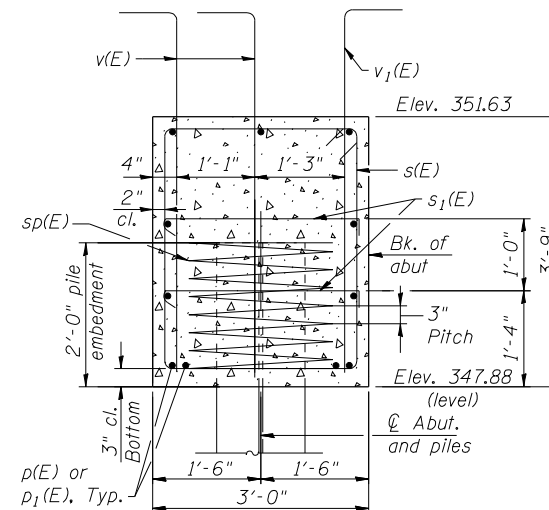

**SECTION THRU  
EAST ABUTMENT**

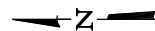

USER NAME = has	DESIGNED - SHL 12/12	REVISED -
ESCA PROJECT NO. 988.12	CHECKED - RDP 03/13	REVISED -
PLOT SCALE = 1/2" = 1' / IN.	DRAWN - HAS 12/12	REVISED -
PLOT DATE = 8/2/2013 11:39:58 AM	CHECKED - ELH 07/13	REVISED -

**STATE OF ILLINOIS  
DEPARTMENT OF TRANSPORTATION**

**EAST ABUTMENT  
STRUCTURE NO. 076-0032**

SHEET NO. 15 OF 21 SHEETS

F.A.P. RTE.	SECTION	COUNTY	TOTAL SHEETS	SHEET NO.
885	112B-1	POPE	56	37
ILLINOIS FED. AID PROJECT AID			CONTRACT NO. 78230	

**PIER 1  
BILL OF MATERIAL**

Bar	No.	Size	Length	Shape
$h_2(E)$	12	#5	17'-8"	—
$h_3(E)$	12	#5	18'-8"	—
$p(E)$	7	#7	16'-10"	—
$D_1(E)$	7	#7	17'-10"	—
$s_2(E)$	96	#4	3'-3"	□
$s_3(E)$	31	#4	10'-5"	□
$u_1(E)$	12	#5	9'-4"	U
$u_2(E)$	6	#5	7'-8"	U
$v_4(E)$	76	#5	8'-4"	—
$v_5(E)$	38	#5	3'-8"	—
Cofferdam Excavation	Cu. Yd.		65	
Concrete Structures	Cu. Yd.		29.6	
Reinforcement Bars, Epoxy Coated	Pound		2350	
Cofferdam (Type 1) (Location 1)	Each		1	
Test Pile, Steel HP14x89	Each		1	
Furnishing Steel Piles, HP14x89	Foot		441	
Driving Piles	Foot		441	
Bar Splicers	Each		19	

For details of piles, see sheet 18 of 21.  
For details of Bar Splicers, see sheet 19 of 21.

**PILE DATA**

Type: Steel HP14x89  
Nominal Required Bearing: 705 kips  
Factored Resistance Available: 388 kips  
Estimated Length: 63'  
No. of Production Piles: 7  
No. of Test Piles: 1

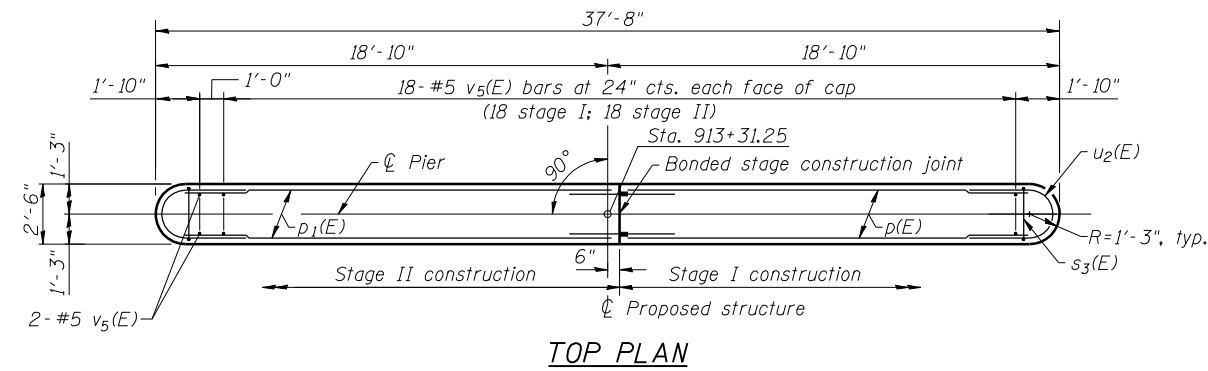

**TOP PLAN**

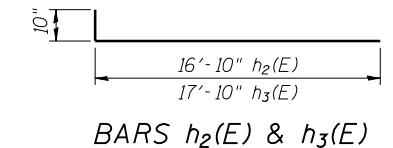

**BARS  $h_2(E)$  &  $h_3(E)$**

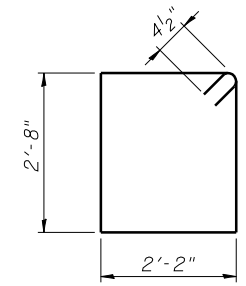

**BAR  $s_3(E)$**

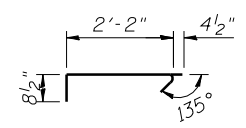

**BAR  $s_2(E)$**

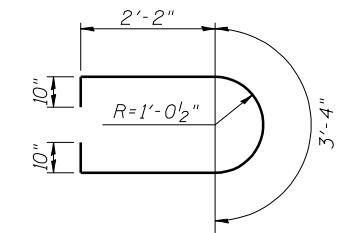

**BAR  $u_1(E)$**

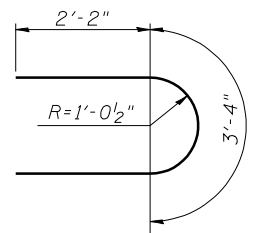

**BAR  $u_2(E)$**

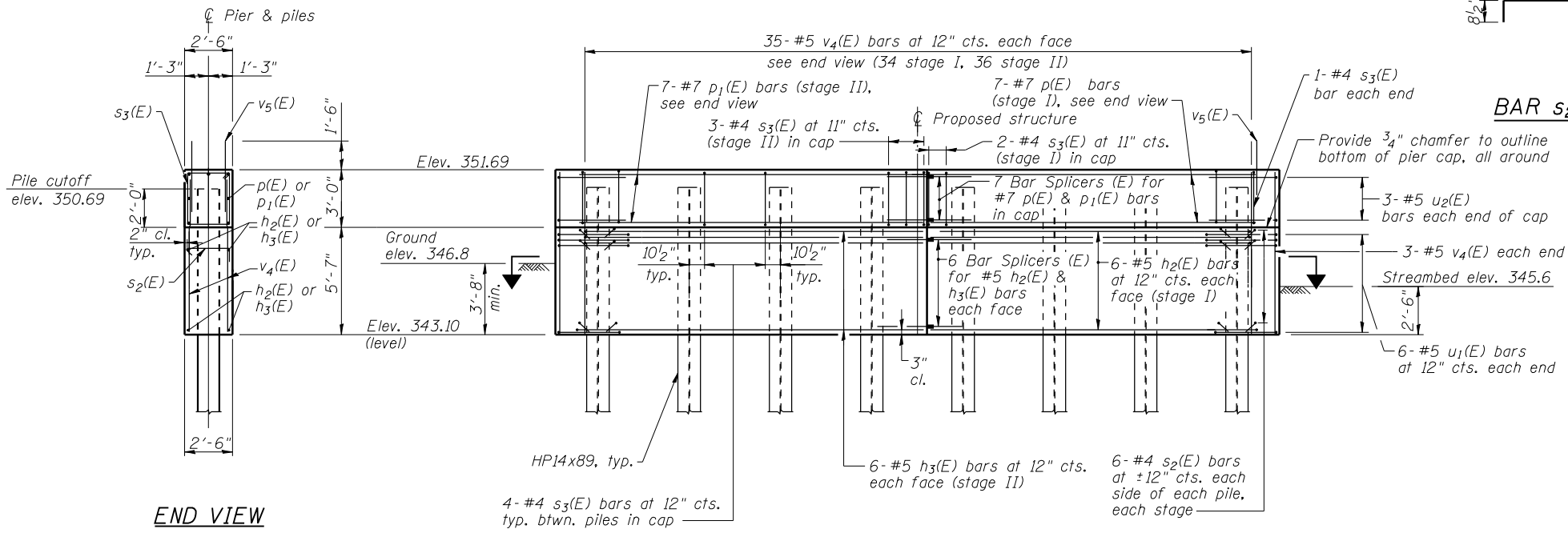

**ELEVATION  
(Looking East)**

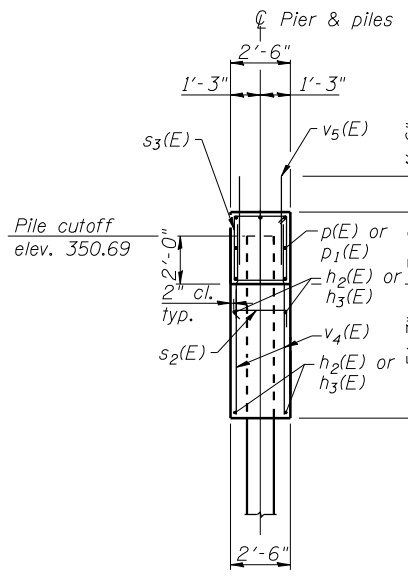

**END VIEW**

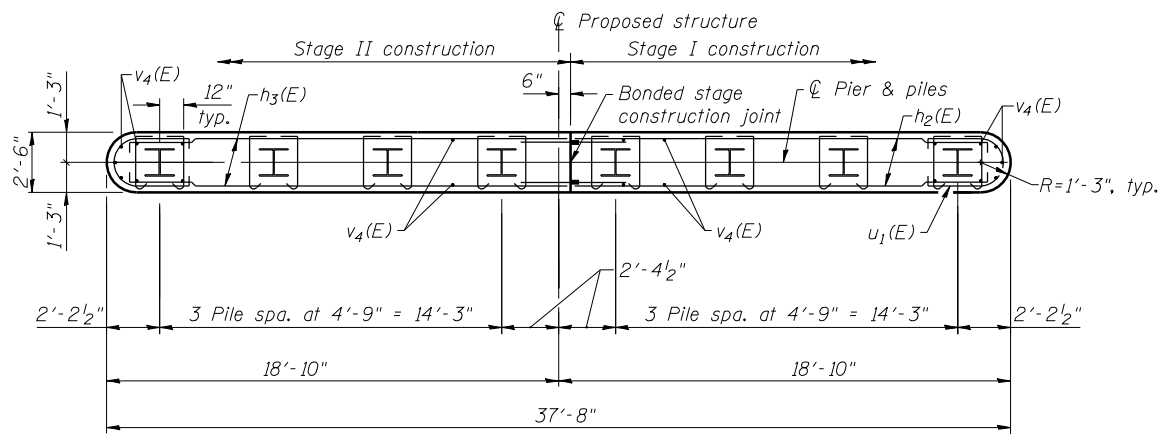

**SECTION**

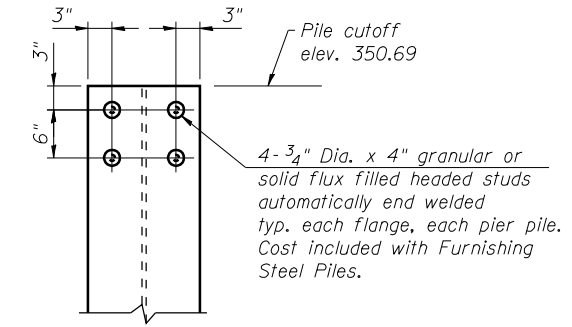

**TOP OF PILE DETAIL**



USER NAME = has	DESIGNED - SHL 12/12	REVISED -
ESCA PROJECT NO. 988.12	CHECKED - RDP 03/13	REVISED -
PLOT SCALE = 0.2' / IN.	DRAWN - HAS 12/12	REVISED -
PLOT DATE = 8/2/2013 11:40:20 AM	CHECKED - RDP 06/13	REVISED -

**STATE OF ILLINOIS  
DEPARTMENT OF TRANSPORTATION**

**PIER 1  
STRUCTURE NO. 076-0032**

SHEET NO. 16 OF 21 SHEETS

F.A.P. RTE.	SECTION	COUNTY	TOTAL SHEETS	SHEET NO.
885	112B-1	POPE	56	38
ILLINOIS FED. AID PROJECT AID			CONTRACT NO. 78230	

**PIER 2  
BILL OF MATERIAL**

Bar	No.	Size	Length	Shape
$h_2(E)$	12	#5	17'-8"	—
$h_3(E)$	12	#5	18'-8"	—
$p(E)$	7	#7	16'-10"	—
$D_1(E)$	7	#7	17'-10"	—
$s_2(E)$	96	#4	3'-3"	□
$s_3(E)$	31	#4	10'-5"	□
$u_1(E)$	12	#5	9'-4"	U
$u_2(E)$	6	#5	7'-8"	U
$v_4(E)$	76	#5	8'-4"	—
$v_5(E)$	38	#5	3'-8"	—
Cofferdam Excavation	Cu. Yd.		55	
Concrete Structures	Cu. Yd.		29.6	
Reinforcement Bars, Epoxy Coated	Pound		2350	
Cofferdam (Type 1) (Location 2)	Each		1	
Test Pile, Steel HP14x89	Each		1	
Furnishing Steel Piles, HP14x89	Foot		427	
Driving Piles	Foot		427	
Bar Splicers	Each		19	

For details of piles, see sheet 18 of 21.  
For details of Bar Splicers, see sheet 19 of 21.

**PILE DATA**

Type: Steel HP14x89  
Nominal Required Bearing: 705 kips  
Factored Resistance Available: 386 kips  
Estimated Length: 61'  
No. of Production Piles: 7  
No. of Test Piles: 1

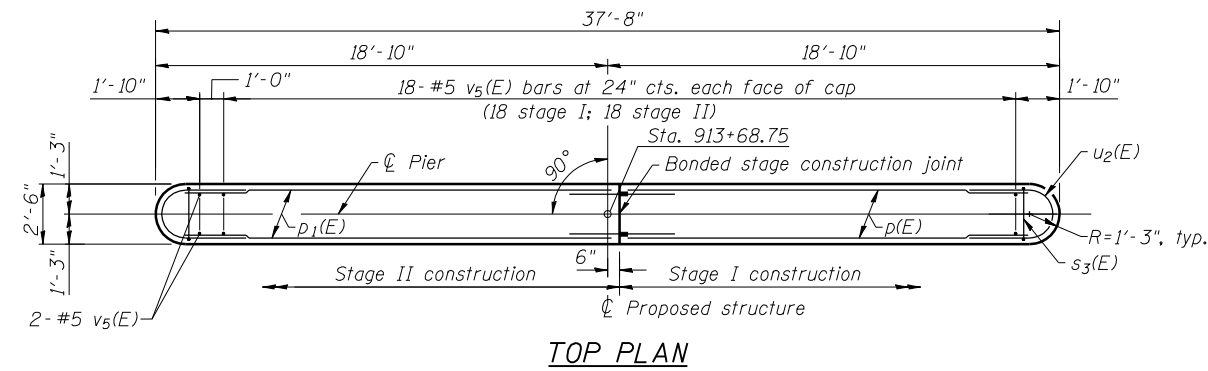

**TOP PLAN**

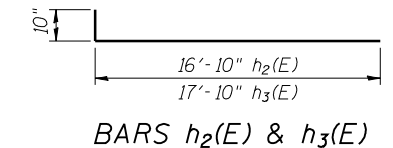

**BARS  $h_2(E)$  &  $h_3(E)$**

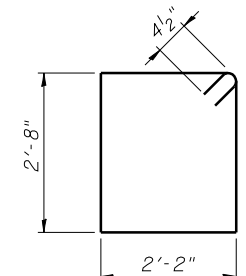

**BAR  $s_3(E)$**

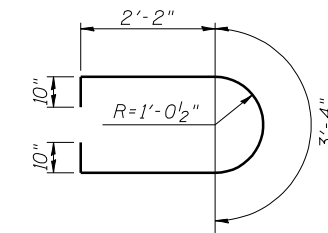

**BAR  $u_1(E)$**

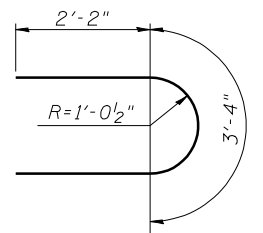

**BAR  $u_2(E)$**

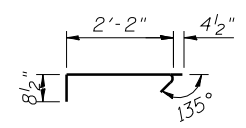

**BAR  $s_2(E)$**

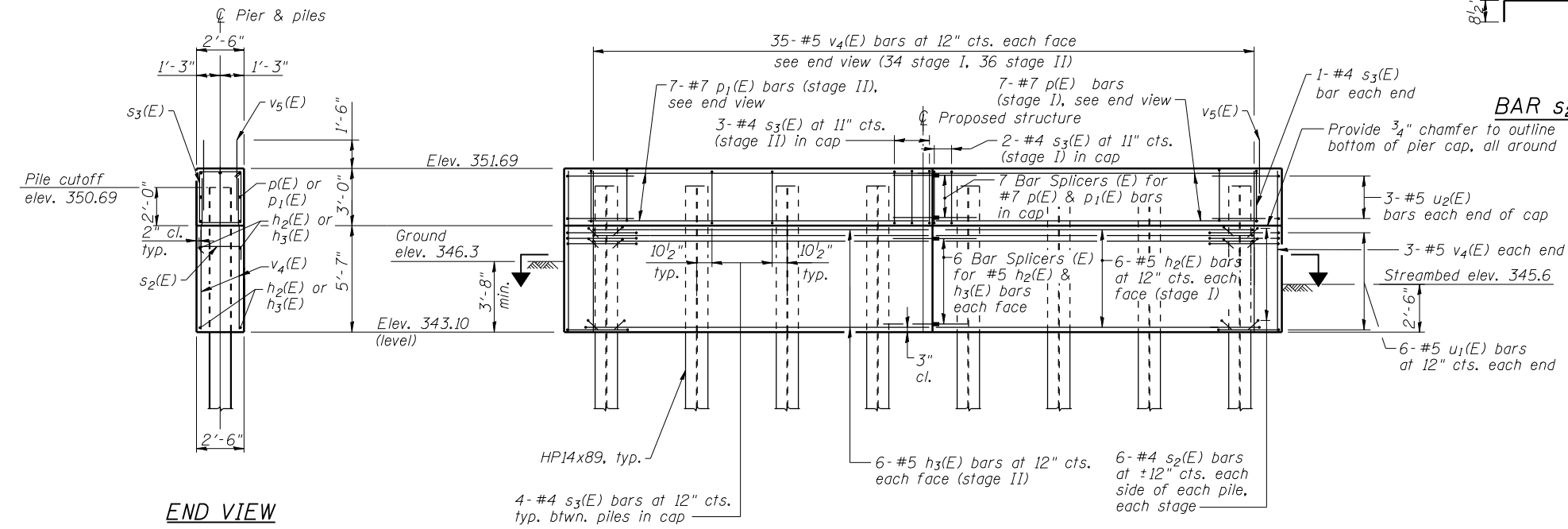

**ELEVATION  
(Looking East)**

**END VIEW**

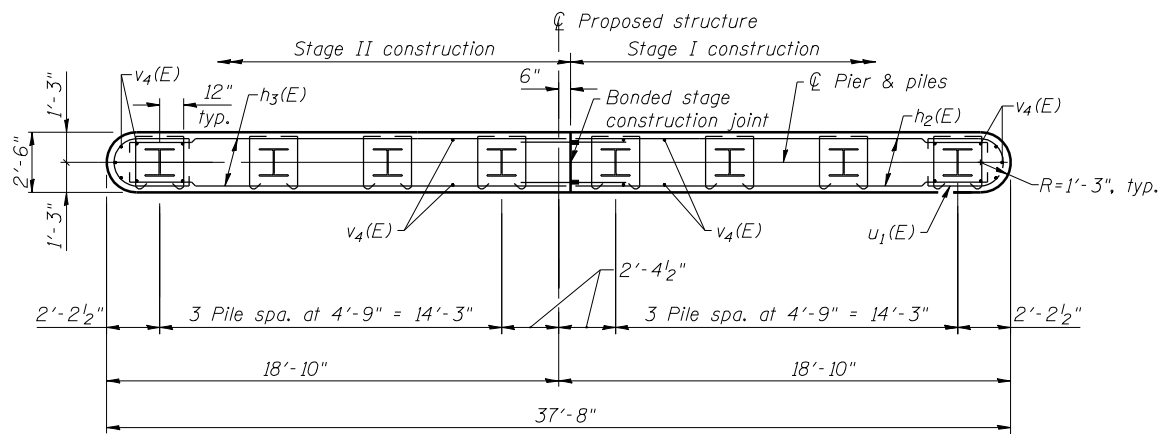

**SECTION**

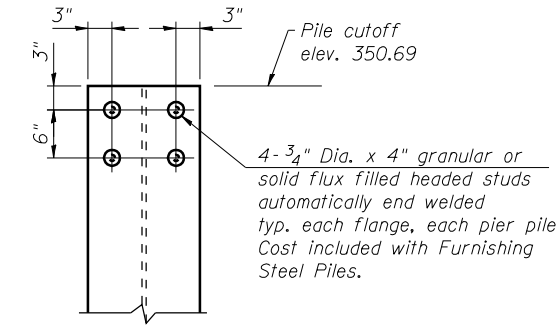

**TOP OF PILE DETAIL**



USER NAME = has	DESIGNED - SHL 12/12	REVISED -
ESCA PROJECT NO. 988.12	CHECKED - RDP 03/13	REVISED -
PLOT SCALE = 1/4" = 1' / IN.	DRAWN - HAS 12/12	REVISED -
PLOT DATE = 8/2/2013 11:40:47 AM	CHECKED - RDP 06/13	REVISED -

**STATE OF ILLINOIS  
DEPARTMENT OF TRANSPORTATION**

**PIER 2  
STRUCTURE NO. 076-0032**

SHEET NO. 17 OF 21 SHEETS

F.A.P. RTE.	SECTION	COUNTY	TOTAL SHEETS	SHEET NO.
885	112B-1	POPE	56	39
CONTRACT NO. 78230				
ILLINOIS FED. AID PROJECT AID				

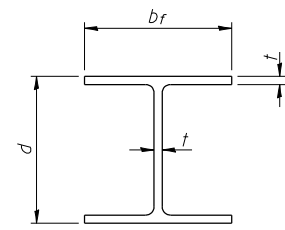

**STEEL PILE TABLE**

Designation	Depth d	Flange width br	Web and Flange thickness t	Encasement diameter A
HP 14x117	14 1/4"	14 7/8"	13/16"	30"
x102	14"	14 3/4"	1/16"	30"
x89	13 7/8"	14 3/4"	5/8"	30"
x73	13 5/8"	14 5/8"	1/2"	30"
HP 12x84	12 1/4"	12 1/4"	1/16"	24"
x74	12 1/8"	12 1/4"	5/8"	24"
x63	12"	12 1/8"	1/2"	24"
x53	11 3/4"	12"	7/16"	24"
HP 10x57	10"	10 1/4"	9/16"	24"
x42	9 3/4"	10 1/8"	7/16"	24"
HP 8x36	8"	8 1/8"	7/16"	18"

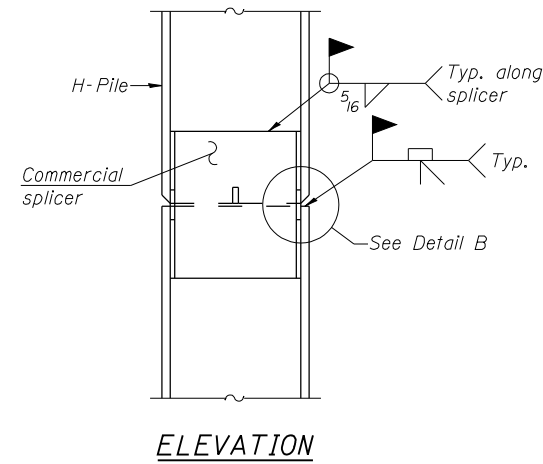

**ELEVATION**

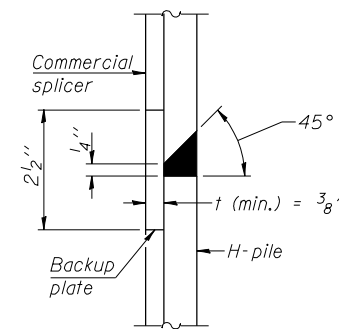

**DETAIL "B"**

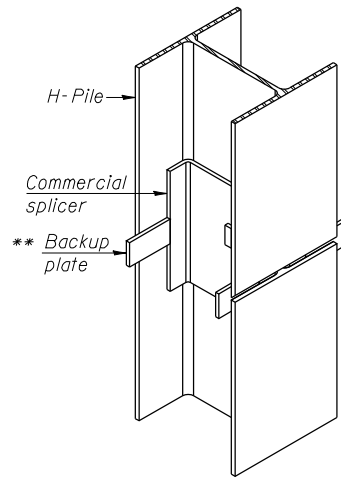

**ISOMETRIC VIEW**

**WELDED COMMERCIAL SPLICE**

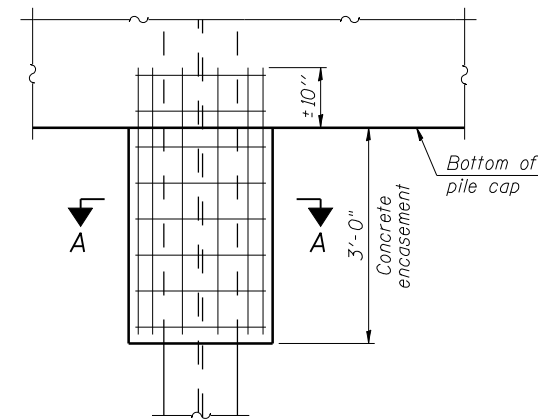

**ELEVATION**

**PILE ENCASEMENT**

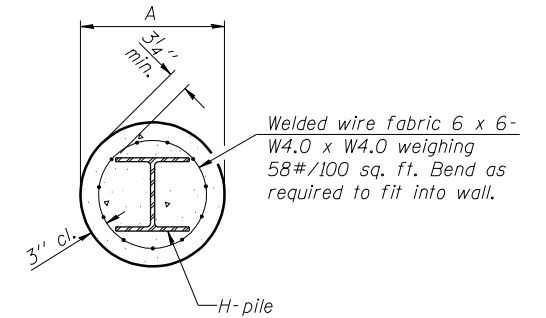

**SECTION A-A**

Note:  
Forms for encasement may be omitted when soil conditions permit.

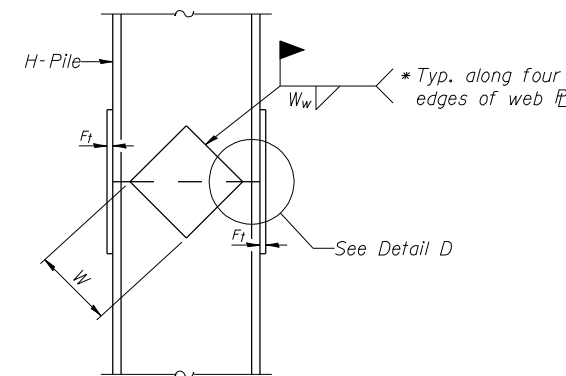

**ELEVATION**

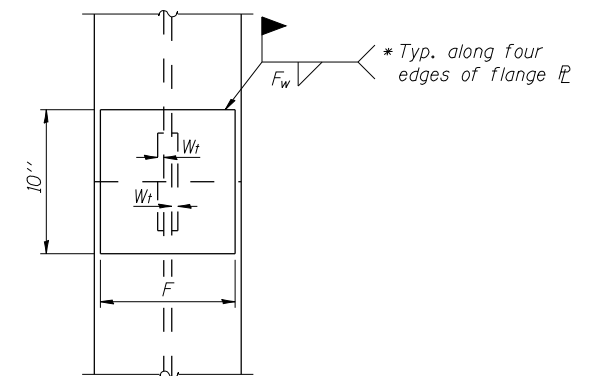

**END VIEW**

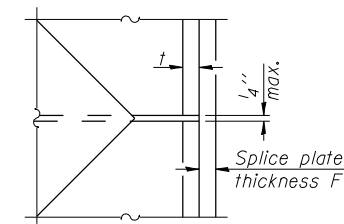

**DETAIL D**

**WELDED PLATE FIELD SPLICE**

Designation	F	Ft	Fw	W	Wt	Ww
HP 14x117	12 1/2"	1"	7/8"	7 3/4"	5/8"	1/2"
x102	12 1/2"	7/8"	3/4"	7 3/4"	5/8"	1/2"
x89	12 1/2"	3/4"	1/16"	7 3/4"	5/8"	1/2"
x73	12 1/2"	5/8"	9/16"	7 3/4"	5/8"	1/2"
HP 12x84	10"	7/8"	1/16"	6 1/2"	5/8"	1/2"
x74	10"	7/8"	1/16"	6 1/2"	5/8"	1/2"
x63	10"	5/8"	1/2"	6 1/2"	1/2"	3/8"
x53	10"	5/8"	1/2"	6 1/2"	1/2"	3/8"
HP 10x57	8"	3/4"	9/16"	5 1/4"	1/2"	3/8"
x42	8"	5/8"	9/16"	5 1/4"	1/2"	3/8"
HP 8x36	7"	5/8"	7/16"	4 1/4"	1/2"	3/8"

**WELDED COMMERCIAL SPLICE ALTERNATE**

- \* Interrupt welds 1/4" from end of web and/or each flange.
- \*\* Remove portions of backup plates that extend outside the flanges.
- \*\*\* Weld size per pile shoe manufacturer (5/16" min.).

Note:  
The steel H-piles shall be according to AASHTO M270 Grade 50.

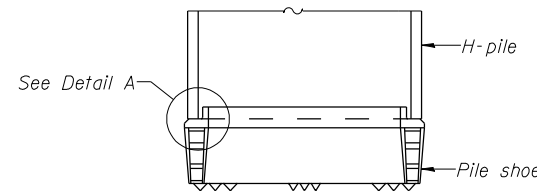

**ELEVATION**

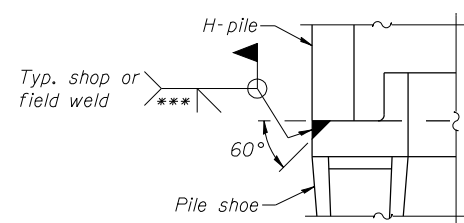

**DETAIL A**

**H-PILE SHOE ATTACHMENT**

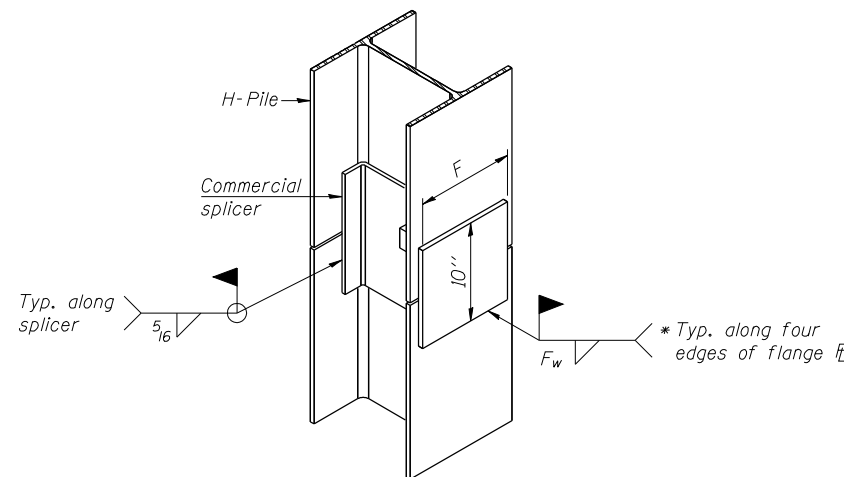

**ISOMETRIC VIEW**

PRINT DRIVER = L:\ESCA\B\A\11  
 PLOT DATE = 8/2/2013 11:41:09 AM  
 PLOT SCALE = 0.25" = 1'-0"  
 FILE NAME = F:\HP\885\112B-1\HP-112B-1.dwg

F-HP 1-27-12



USER NAME = has	DESIGNED - SHL 12/12	REVISED -
ESCA PROJECT NO. 988.12	CHECKED - RDP 03/13	REVISED -
PLOT SCALE = 0.25" = 1'-0"	DRAWN - HAS 12/12	REVISED -
PLOT DATE = 8/2/2013 11:41:09 AM	CHECKED - RDP 03/13	REVISED -

**STATE OF ILLINOIS  
DEPARTMENT OF TRANSPORTATION**

**HP PILE DETAILS  
STRUCTURE NO. 097-0078**

SHEET NO. 18 OF 21 SHEETS

F.A.P. RTE.	SECTION	COUNTY	TOTAL SHEETS	SHEET NO.
885	112B-1	POPE	56	40
CONTRACT NO. 78230			ILLINOIS FED. AID PROJECT AID	



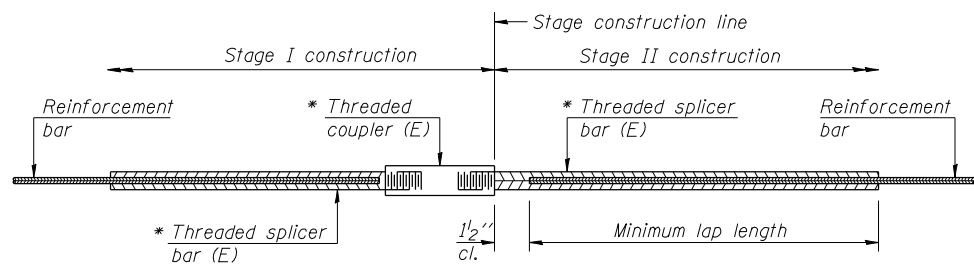

**STANDARD BAR SPLICER ASSEMBLY**

Minimum Lap Lengths						
Bar size to be spliced	Table 1	Table 2	Table 3	Table 4	Table 5	Table 6
3, 4	1'-5"	1'-11"	2'-1"	2'-4"	2'-7"	2'-11"
5	1'-9"	2'-5"	2'-7"	2'-11"	3'-3"	3'-8"
6	2'-1"	2'-11"	3'-1"	3'-6"	3'-10"	4'-5"
7	2'-9"	3'-10"	4'-2"	4'-8"	5'-2"	5'-10"
8	3'-8"	5'-1"	5'-5"	6'-2"	6'-9"	7'-8"
9	4'-7"	6'-5"	6'-10"	7'-9"	8'-7"	9'-8"

- Table 1: Black bar, 0.8 Class C
- Table 2: Black bar, Top bar lap, 0.8 Class C
- Table 3: Epoxy bar, 0.8 Class C
- Table 4: Epoxy bar, Top bar lap, 0.8 Class C
- Table 5: Epoxy bar, Class C
- Table 6: Epoxy bar, Top bar lap, Class C

Threaded splicer bar length = min. lap length + 1 1/2" + thread length

\* Epoxy not required on Bar Splicer Assembly components used in conjunction with black bars.

Location	Bar size	No. assemblies required	Table for minimum lap length
Approach slabs	#4	50	3
Approach slabs	#5	92	3
Approach footings	#5	80	3
Top bridge slab	#5	67	4
Bottom bridge slab	#5	110	3
Abutments	#7	22	4
Pier caps	#7	14	4
Pier walls	#5	24	3

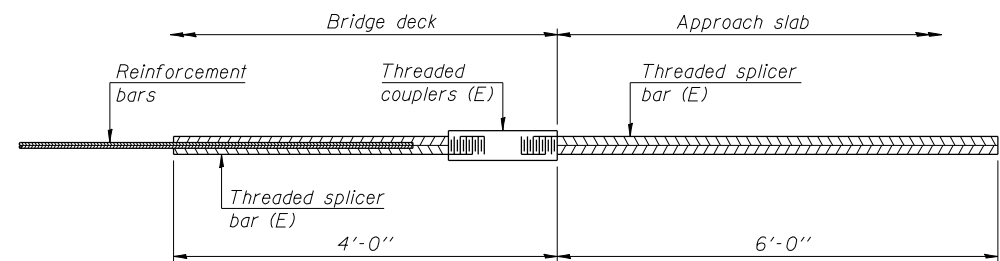

**BAR SPLICER ASSEMBLY FOR #5 BAR ON INTEGRAL OR SEMI-INTEGRAL ABUTMENTS**

No. required = 0

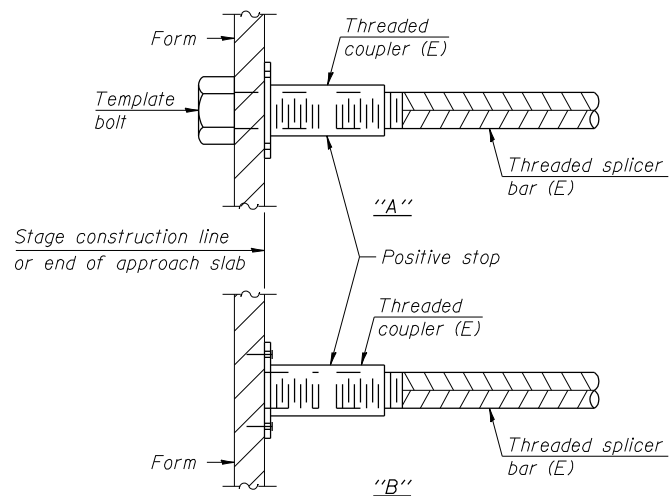

**INSTALLATION AND SETTING METHODS**

"A" : Set bar splicer assembly by means of a template bolt.  
 "B" : Set bar splicer assembly by nailing to wood forms or cementing to steel forms.  
 (E) : Indicates epoxy coating.

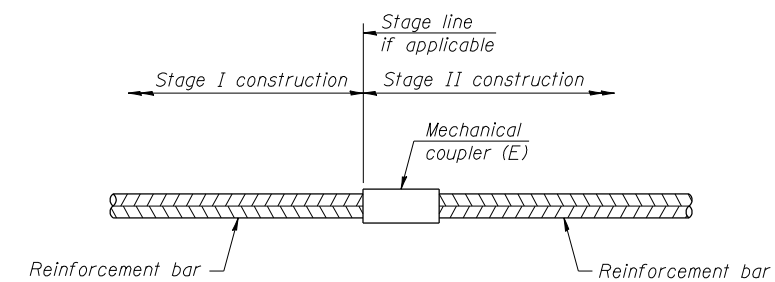

**STANDARD MECHANICAL SPLICER**

Location	Bar size	No. assemblies required
NA		

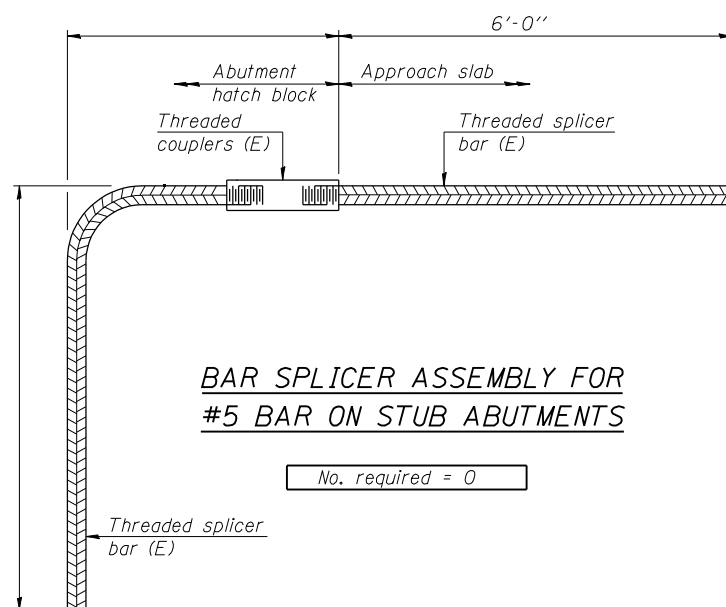

**BAR SPLICER ASSEMBLY FOR #5 BAR ON STUB ABUTMENTS**

No. required = 0

**NOTES**

Splicer bars shall be deformed with threaded ends and have a minimum 60 ksi yield strength.  
 All reinforcement shall be lapped and tied to the splicer bars.  
 Bar splicer assemblies shall be epoxy coated according to the requirements for reinforcement bars. See Section 508 of the Standard Specifications.  
 See approved list of bar splicer assemblies and mechanical splicers for alternatives.

PRINT DRIVER = L:\D-ESCA\B\PLT  
 FILE NAME = 8/2/2013 11:41:29 AM 19-08-01.dwg

BSD-1

1-27-12



USER NAME = has	DESIGNED - SHL 12/12	REVISED -
ESCA PROJECT NO. 988.12	CHECKED - RDP 03/13	REVISED -
PLOT SCALE = 0/2" = 1" / IN.	DRAWN - HAS 12/12	REVISED -
PLOT DATE = 8/2/2013 11:41:29 AM	CHECKED - RDP 06/13	REVISED -

**STATE OF ILLINOIS  
DEPARTMENT OF TRANSPORTATION**

**BAR SPLICER ASSEMBLY AND MECHANICAL SPLICER DETAILS  
STRUCTURE NO. 097-0078**

SHEET NO. 19 OF 21 SHEETS

F.A.P. RTE.	SECTION	COUNTY	TOTAL SHEETS	SHEET NO.
885	112B-1	POPE	56	41
CONTRACT NO. 78230				
ILLINOIS FED. AID PROJECT AID				



ILLINOIS DEPARTMENT OF TRANSPORTATION  
 District Nine Materials  
 Bridge Foundation  
 Boring Log  
 Sheet 1 of 2

FAP 885 (IL 146) Over Flat Lick Branch  
 No. : FAP 885 (IL 146) Structure Number: 076-0009 Date: 7/2/2010  
 Section 112-BDR Bored By: R Moberly  
 County: Pope Location: 4.2 mile East of IL 145 Checked By: R Graeff

D E P T H		B L O W S		Qu tsf	W%	Surf Wat Elev: 347.0	D E P T H		B L O W S		Qu tsf	W%		
Asphalt and concrete over crushed aggregate						351.8	Stiff, moist, brown, Silty Clay to Clay A7-6						4 5	1.3B 22
Soft to medium, very moist, grey, Silty Clay to Silty Clay Loam A-6						348.8	Very stiff, moist, brown, Clay A7-6						4 9 13	3.9B 22
Stiff, moist, grey, Silty Clay Loam A-6						348.3	Stiff, moist, grey, Clay A7-6						30.0 3 9 11	3 3.9B 22
Soft, very moist, grey, Silty Clay A-6						343.8	Medium, very moist, grey, Clay A7-6						3 6 9	2.4B 21
Medium, very moist, grey, Clay A7-6						341.3	Stiff, moist, brown mottled grey, Clay A7-6						35.0 3 5	1 1.6B 31
Stiff, moist, brown mottled grey, Clay A7-6						313.8	Medium, very moist, grey, Clay A7-6						43.0 WH 1 1	WH 2 0.9B 24
Medium, very moist, grey, Silty Clay to Clay A-6						336.3	Medium, very moist, grey, Clay A7-6						20.0 2 6 9	WH 45.0 WH 1 0.7B 26
Very stiff, moist, brown mottled grey, Clay A7-6						328.8	Medium, very moist, grey, Clay A7-6						3 7 9	3.5B 23
Ground Surface 353.3 Ft						25.0	303.3						50.0	1

N-Std Penr Test: 2" OD Sampler, 140# Hammer, 30" Fall (Type Fall. B-Bulge S-Shear E-Estimated P-Penetrometer)

Sheet 2 of 2  
 Date: 7/2/2010

Ro. : FAP 885 (IL 146)  
 Section: 112-BDR  
 County: Pope

D E P T H		B L O W S		Qu tsf	W%	Boring No: 2-9	D E P T H		B L O W S		Qu tsf	W%		
Very stiff, moist, grey, Clay A7-6						298.8	Medium, very moist, grey, Clay A7-6						3 4	2.2B 22
Medium, very moist, grey, Clay A7-6						293.3	Hard, damp, brown and grey, Weathered Clay Shale with Sandstone layers						55.0 WH 2 2	WH 0.8B 18
Hard, damp to dry, grey, Sandy Clay Shale						289.8	Hard, damp to dry, grey, Sandy Clay Shale						60.0 3	32 38
Bottom of hole= 63.3 feet						290.8	Hard, damp to dry, grey, Sandy Clay Shale						100/10"	12
Free water observed at 27.0 feet						289.8	Bottom of hole= 63.3 feet						65.0	90.0
Elevation referenced to BM at NE corner; Elev. = 351.5 feet						75.0	Free water observed at 27.0 feet						70.0	85.0
To convert "N" value to "N60" multiply by 1.25							Elevation referenced to BM at NE corner; Elev. = 351.5 feet							
Ground Surface 353.3 Ft							To convert "N" value to "N60" multiply by 1.25							

N-Std Penr Test: 2" OD Sampler, 140# Hammer, 30" Fall (Type Fall. B-Bulge S-Shear E-Estimated P-Penetrometer)

PRINT DRIVER: L:\D-E\B\B\11  
 ESCA PROJECT NO. 988.12  
 PLOT SCALE: 1/4" = 1'-0"  
 PLOT DATE: 8/2/2013 11:42:08 AM



USER NAME = has	DESIGNED - SHL 12/12	REVISED -
ESCA PROJECT NO. 988.12	CHECKED - RDP 03/13	REVISED -
PLOT SCALE = 1/4" = 1'-0"	DRAWN - HAS 12/12	REVISED -
PLOT DATE = 8/2/2013 11:42:08 AM	CHECKED - SHL 03/13	REVISED -

STATE OF ILLINOIS  
 DEPARTMENT OF TRANSPORTATION

BORING LOGS  
 STRUCTURE NO. 076-0032

F.A.P. RTE.	SECTION	COUNTY	TOTAL SHEETS	SHEET NO.
885	112B-1	POPE	56	43
			CONTRACT NO. 78230	
ILLINOIS FED. AID PROJECT AID				

SHEET NO. 21 OF 21 SHEETS

BM: Sq. Cut in So. West corner of bridge, 12' ft. Sta. 913+25 El. 353.46  
 Existing Structure: R.C.D.G. 2 Spans @ 33'-0" each with R.C. Closed Abutts.  
 Built as S.D.I. Rt. 146, Sec. 112 B, in 1928 @ Sta. 913+50.00  
 Contractor to remove and replace superstructure a portion at a time utilizing stage construction as shown.  
 Bk. to Bk. of Abut. 76'-0", Out to Out - 24'-8"  
 Str. No. 076-0009

STATE OF ILLINOIS  
 DEPARTMENT OF TRANSPORTATION

ROUTE NO.	SECTION	COUNTY	TOTAL SHEETS	SHEET NO.
112B-DR	DR	Peoria	16	9
SHEET NO. 1 8 SHEETS				

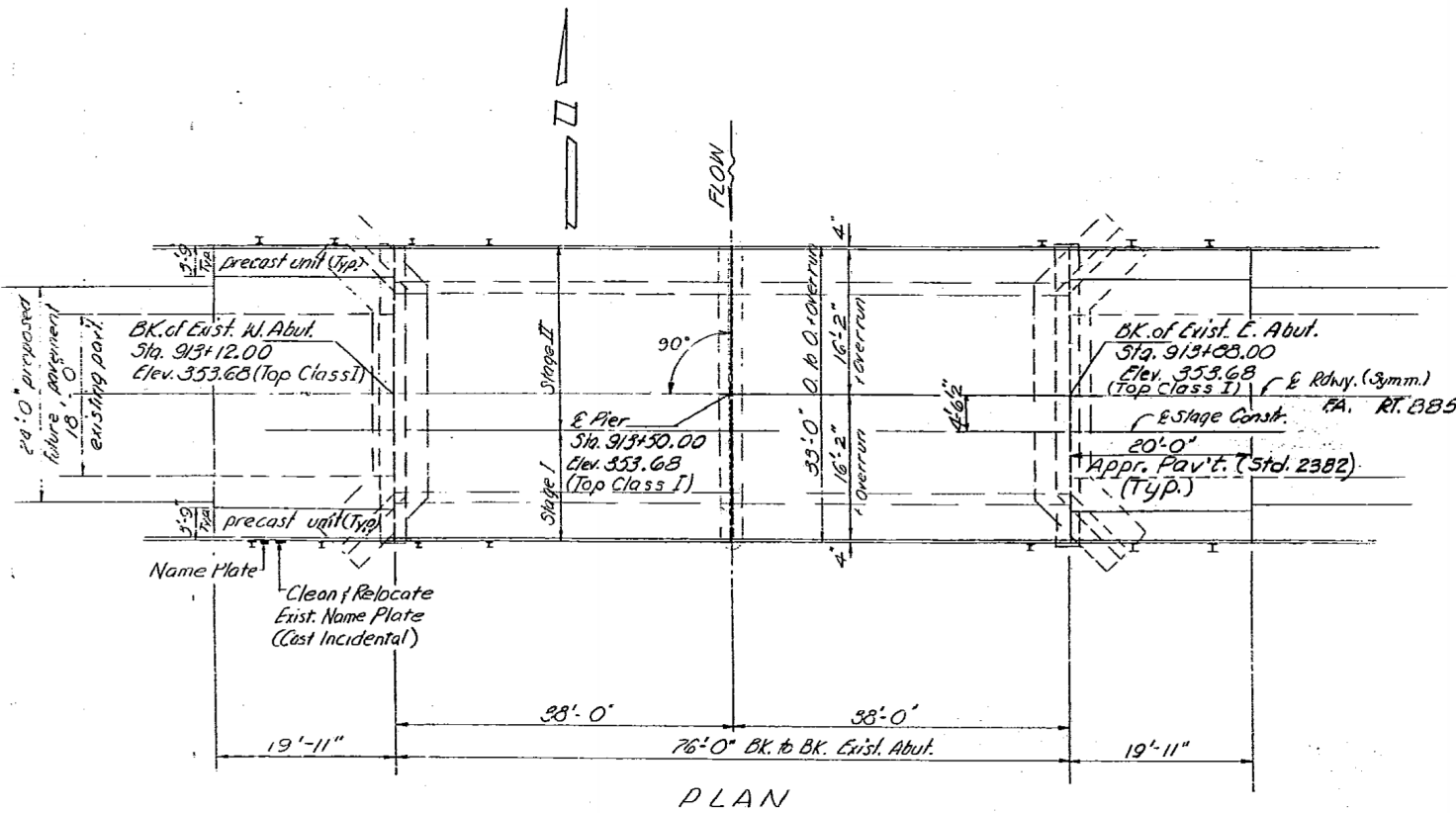
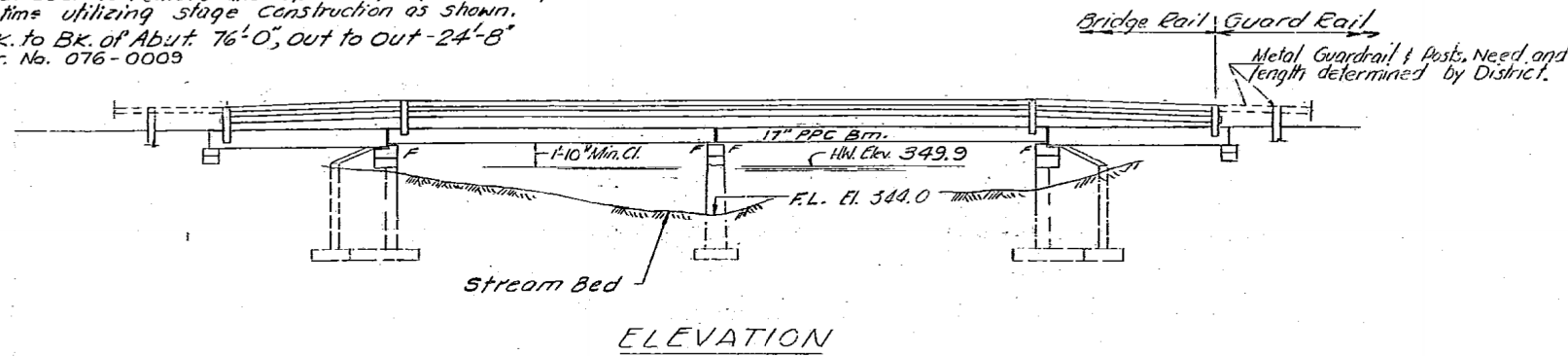

STATION 913+50.00  
 REBUILT 198 BY  
 STATE OF ILLINOIS  
 F.A. RT. 885 SEC. 112 B-DR  
 F.A. PROJECT BH-F-885(12)  
 LOADING HS20  
 \* STR. NO.

NAME PLATE  
 (See Std. 2113)  
 \* Structure No. to be supplied by the District.

GENERAL NOTES

Expansion guards which are not cast in the precast unit shall be fabricated and erected in accordance with Article 505.07(c) of the Standard Specifications and are included in quantity of structural steel.  
 Plan dimensions and details relative to existing structure have been taken from existing plans and are subject to nominal construction variations. It shall be the Contractor's responsibility to verify such dimensions and details in the field and make necessary approved adjustments prior to construction or ordering of materials. Such variations shall not be cause for additional compensation for a change in the scope of the work, however, the Contractor will be paid for the quantity actually furnished at the unit price bid for the work.  
 The top surface of the beams shall be finished in accordance with Article 505.06 of the Standard Specification except that the surface shall not be roughened by brooming. The finished surface shall be free of depressions or high spots with sharp corners and the top edge of keys shall be rounded or chamfered a min. of 1/4".  
 Expansion bolts shall consist of approved expansion anchors providing min. certified proof load = 4,080 lbs., and 3/4" x 12" hooked bolts.  
 Reinforcement bars shall conform to the requirements of AASHTO M-31 or M-53 Grade 60.  
 Shoulder transition to wingwall shall be shaped with broken concrete. Cost incidental.  
 A Calcium Nitrite Corrosion Inhibitor, as covered in the Special Provisions, shall be used in the concrete for precast prestressed concrete deck beams.

TOTAL BILL OF MATERIAL

Item	Unit	Super	Sub.	Total
Concrete Removal	Cu. Yds.	12.2		12.2
Expansion Bolts (3/4")	Each		64	64
Class X Concrete	Cu. Yds.		25.2	25.2
Precast Concrete Bridge Slab	Sq. Ft.	299		299
P.P.C. Deck Bms. (17")	Sq. Ft.	2500		2500
Steel Railing, Type S-1	Lin. Ft.	232		232
Reinforcement Bars	Lbs.		2970	2970
Removal of Exist. Superstrg.	Each	1		1
Waterproofing Membrane System	Sq. Yds.	293		293
Bit. Conc. Surf. Course Class I	Tons	25		25
Temporary Bridge Rail	Lin. Ft.	116		116
Name Plates	Each	1		1
P.C. Mortar Fairing Course	Lin. Ft.	758		758

NEW CONSTR. LOADING HS20-44

PRECAST PRESTRESSED UNITS

$f_c = 5,000$  psi Allow 25% aft. for future W.S.  
 $f_{ci} = 4,000$  psi  
 $f_s = 270,000$  psi (2 Strands)  
 $f_{st} = 189,000$  psi (2 Strands)

FIELD UNITS

$f'_c = 3500$  (Sub.)  
 $f_y = 60,000$  psi Reinf.

PRECAST UNITS

$f'_c = 4,500$  psi  
 $f_c = 1,800$  psi  
 $f_s = 20,000$  psi

Design Specification 1977 A.A.S.H.T.O.  
 78, 79, 80, 81 Interim Specs. as applicable.

Prop. Redecking

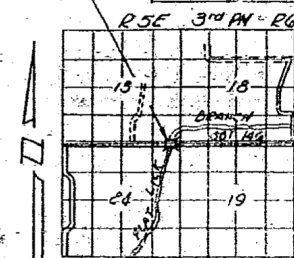

LOCATION SKETCH

GENERAL PLAN & ELEVATION  
 PROJECT RF-161(18)  
 F.A. RT. 885 OVER FLAT LICK  
 BRANCH  
 F.A. RT. 885 (S.D.I. 146) SEC 112 B-DR  
 PEORIA COUNTY  
 STATION 913+50.00

FOR INFORMATION ONLY

WATERWAY INFORMATION

Drainage Area 4.27 Sq. Mi. Low Grade Elev. 352.63' @ Sta. 926+00

Flood	Freq. Yr.	Opening Sq. Ft.		Nat. H.W.E.	Head - Ft.		Headwater EL.		
		Exist.	Prop.		Exist.	Prop.	Exist.	Prop.	
Design	50	3322	318	318	349.9	2.85	2.85	352.75	352.75
Base	100	3847	339	339	350.2	3.09	3.09	353.29	353.29
Overtopping	50	3322	318	318	349.9	2.85	2.85	352.75	352.75
Max. Calc.	500								

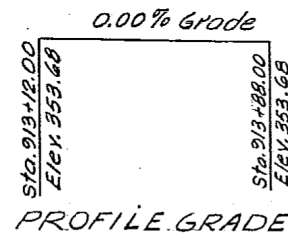

PROFILE GRADE

DESIGNED	JMS	EXAMINED	DECEMBER 28 1970
CHECKED	ANDY YUEN LEE	PASSED	
DRAWN	F. Mercado	APPROVED	
CHECKED	ANDY YUEN LEE	DIRECTOR OF HIGHWAYS	

Rev. 3-8-71 NCC Rev. 9-10-71 WH Rev. 2-15-75 HYL Updated-3-27-81 BYG Updated-10-7-81 BYG Rev. 5-18-83 SKD



USER NAME = has  
 ESCA PROJECT NO. 988.12  
 PLOT SCALE = 0.1667' / IN.  
 PLOT DATE = 8/2/2013 11:42:36 AM

DESIGNED - JMS  
 DRAWN - HAS  
 CHECKED - RDP  
 DATE - 03/13

REVISED -  
 REVISED -  
 REVISED -  
 REVISED -

STATE OF ILLINOIS  
 DEPARTMENT OF TRANSPORTATION

EXISTING STRUCTURE PLANS - FOR INFORMATION ONLY  
 STRUCTURE NO. 076-0009

SCALE: SHEET NO. 1 OF 8 SHEETS STA. TO STA.

F.A.P. RTE.	SECTION	COUNTY	TOTAL SHEETS	SHEET NO.
885	112B-1	POPE	56	44
CONTRACT NO. 78230				
FED. ROAD DIST. NO. ILLINOIS FED. AID PROJECT AID				

STATE OF ILLINOIS  
DEPARTMENT OF TRANSPORTATION

ROUTE NO.	SECTION	COUNTY	TOTAL SHEETS	SHEET NO.
F.A. 885	112 B-DR	POPE	16	10
SHEET NO. 2 8 SHEETS				

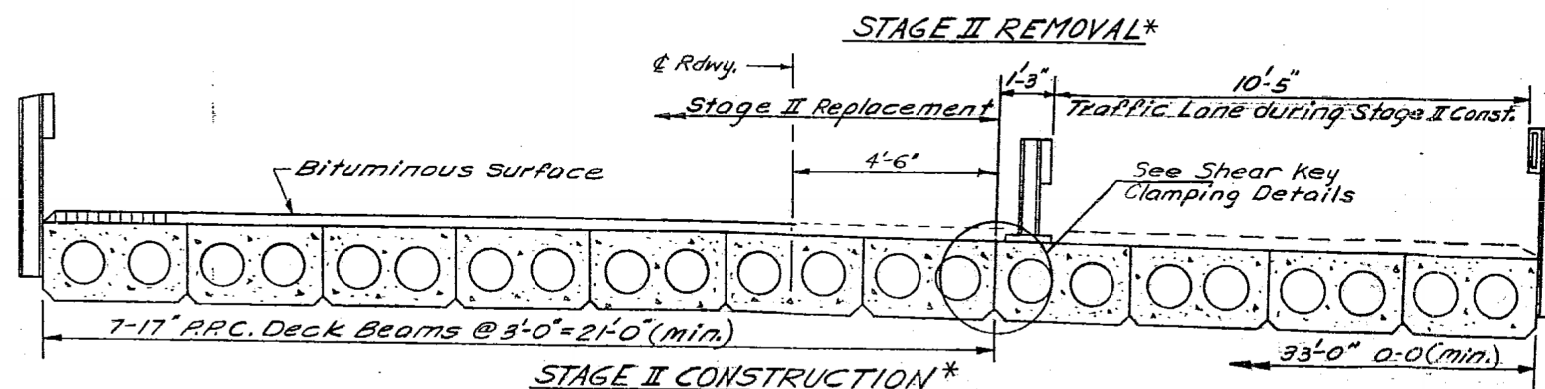
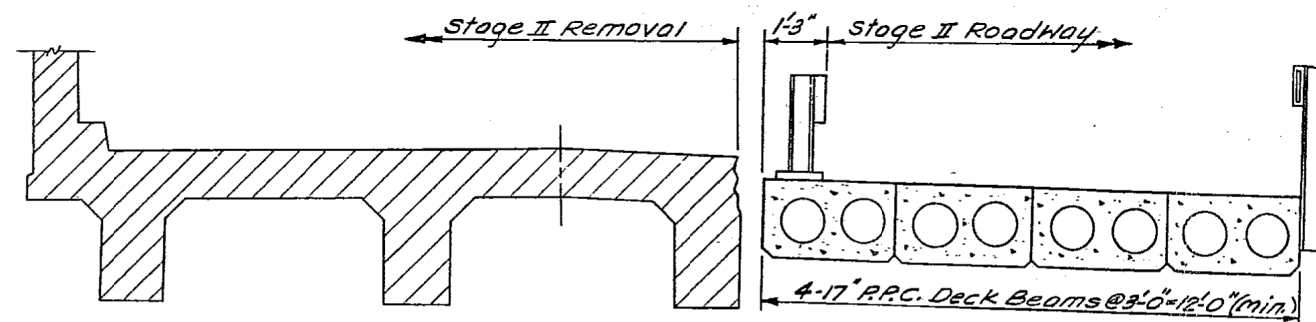
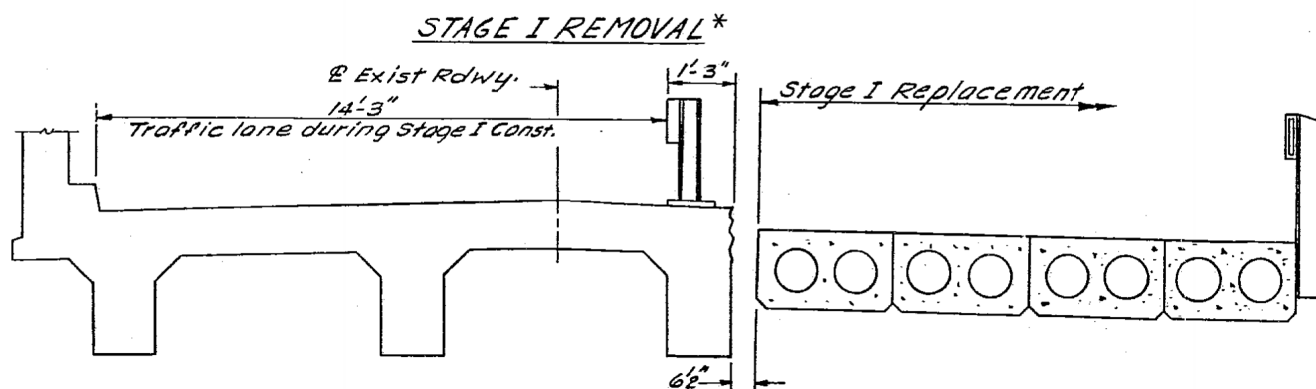
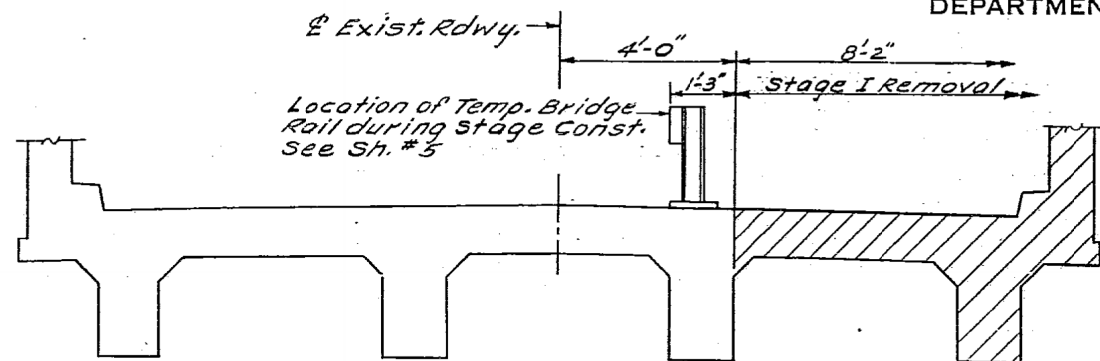

\* Looking East

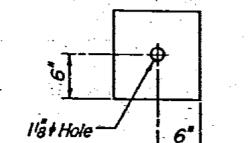
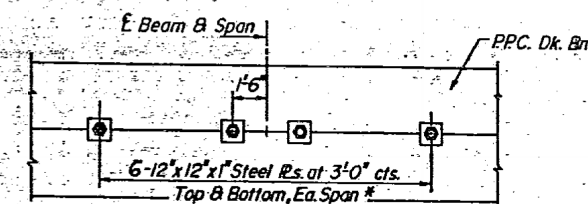

PLAN

CLAMPING PLATE

\* Space plates to miss Temporary Bridge Rail Posts.

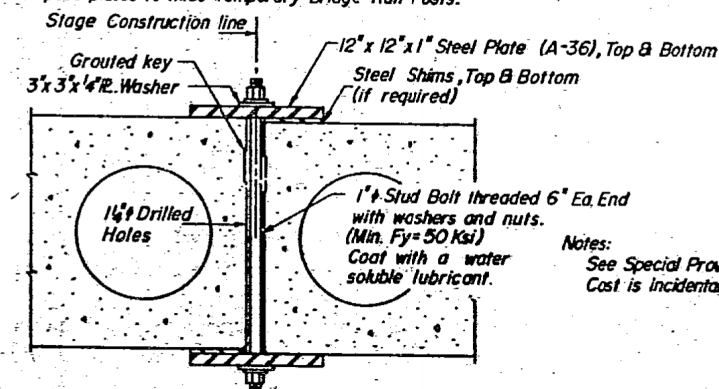

SECTION

SHEAR KEY CLAMPING DETAIL AT STAGE CONSTRUCTION JOINT

Notes:  
See Special Provisions.  
Cost is incidental to PPC Dk. Bms.

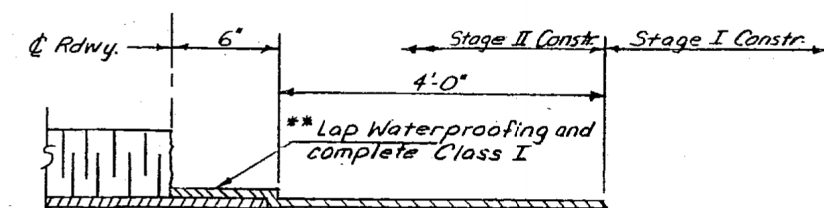

WATERPROOFING TREATMENT

Note:  
Grout 1" Bolt holes in Deck Beams upon removal of Temporary Guardrail before the application of Class I.

\*\* Class I and Waterproofing shall be completed after:  
1.) The deck beams for Stage II Constr. are erected, grouted and waterproofing and Class I are in place.  
2.) Temporary Bridge Rail for Stage II Rdwy. has been removed.  
3.) Shear key clamping devices have been removed.

DESIGNED <i>Benjamin J. Davis</i>	EXAMINED <i>Carl E. Thompson</i>
CHECKED <i>Steven C. Owens</i>	PASSED
DRAWN <i>JH</i>	APPROVED
CHECKED <i>BV6 SCD</i>	

April 8 1981  
DIRECTOR OF HIGHWAYS

FOR INFORMATION ONLY

STAGE CONSTRUCTION DETAILS  
F.A. RT.885 SEC.112B-DR  
POPE COUNTY  
STA. 913+50.00



USER NAME = has	DESIGNED - JMS	REVISED -
ESCA PROJECT NO. 988.12	DRAWN - HAS	REVISED -
PLOT SCALE = 0.1667 / IN.	CHECKED - RDP	REVISED -
PLOT DATE = 8/2/2013 11:42:53 AM	DATE - 03/13	REVISED -

STATE OF ILLINOIS  
DEPARTMENT OF TRANSPORTATION

EXISTING STRUCTURE PLANS - FOR INFORMATION ONLY  
STRUCTURE NO. 076-0009

SCALE: SHEET NO. 2 OF 8 SHEETS STA. TO STA.

F.A.P. RTE.	SECTION	COUNTY	TOTAL SHEETS	SHEET NO.
885	112B-1	POPE	56	45
CONTRACT NO. 78230			ILLINOIS FED. AID PROJECT AID	

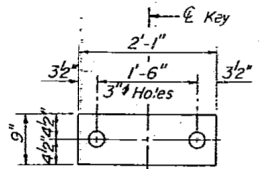

FABRIC BEARING PAD (Interior)

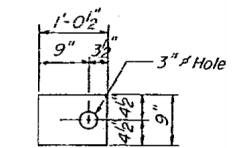

FABRIC BEARING PAD (Exterior)

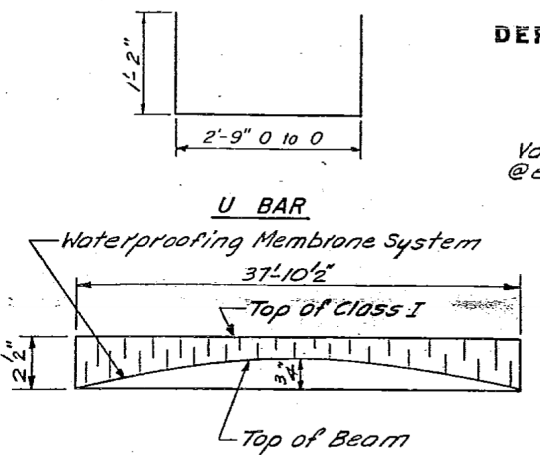

ANTICIPATED CAMBER DIAGRAM

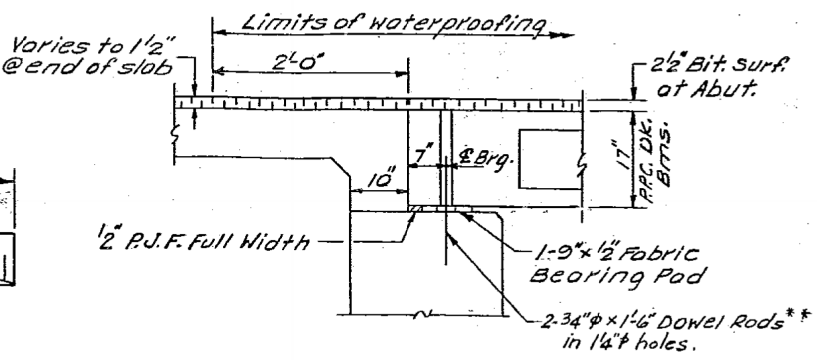

SEC. THRU ABUT. AT RDWY.

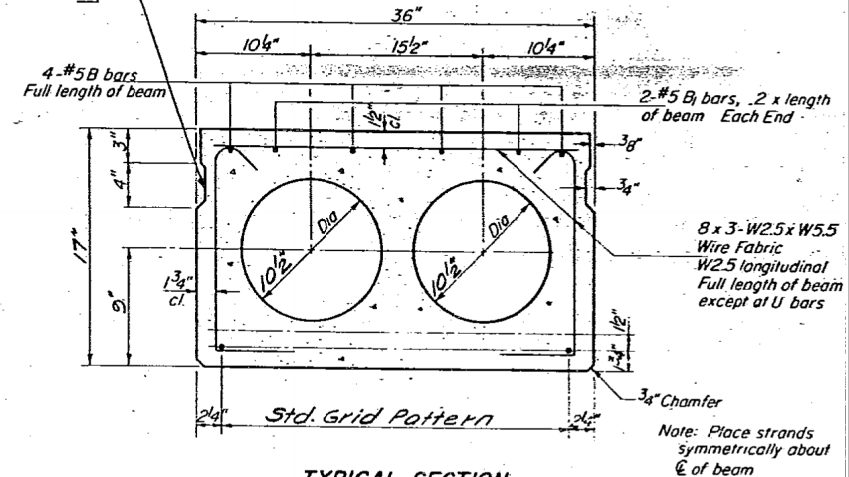

TYPICAL SECTION

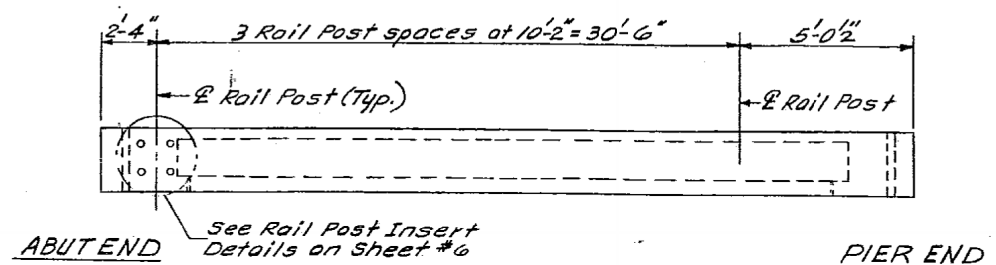

ELEV. FACIA BEAM

1/4" x 3/4" sawed Jt. with Elastic Jt. filler - Full width. See Special Provisions

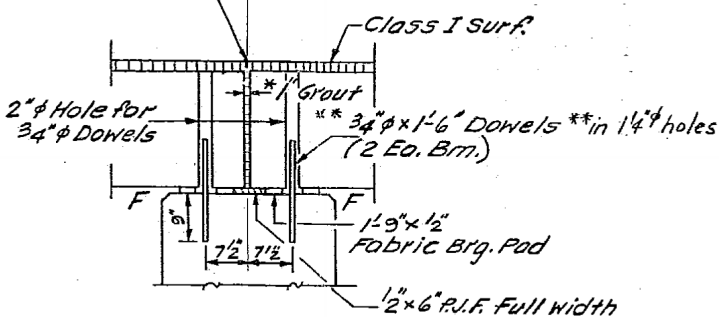

SEC. AT PIER

\*\* Dowel Rods to be grouted after beams are in place and allow to cure (min. 24 hrs.) prior to grouting the shear keys

\* 1" Joint shall be packed with a very dry mix of 2:1 sand and P.C. mortar. This dimension may vary plus or minus to accommodate tolerance in Bm. lengths.

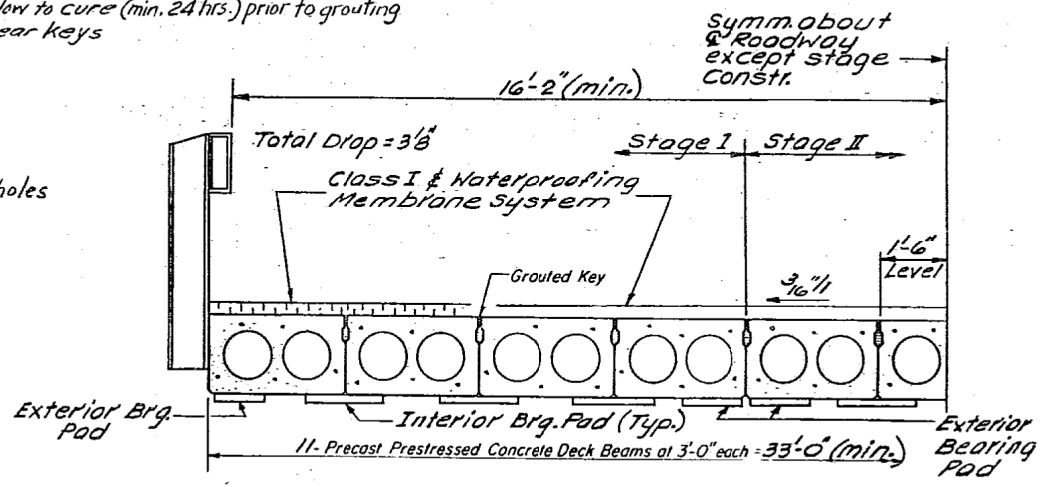

HALF CROSS SECTION Looking West

I/4/19

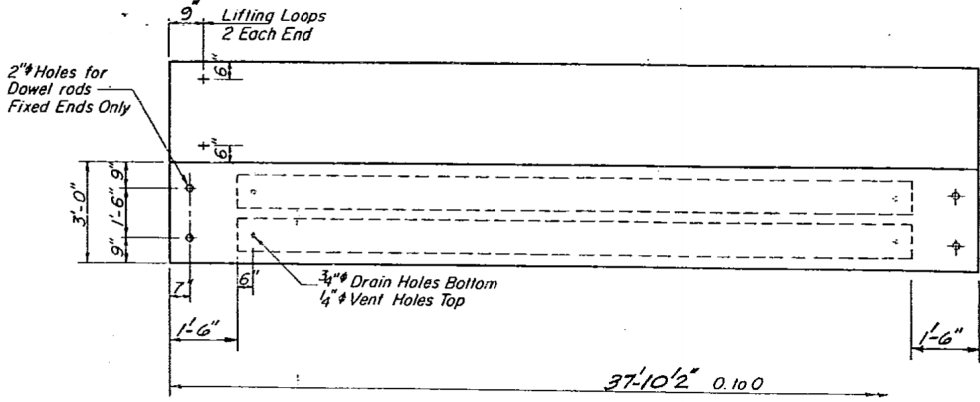

PLAN

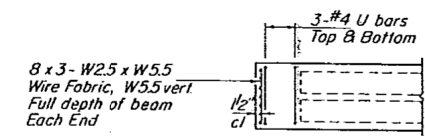

END PLAN

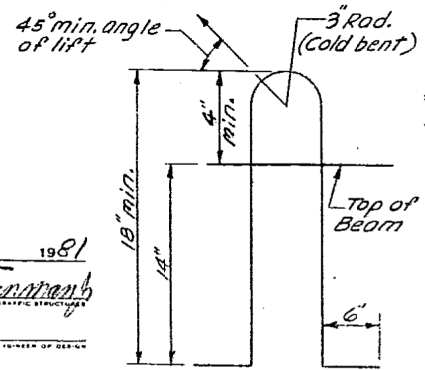

LIFTING LOOP DETAIL

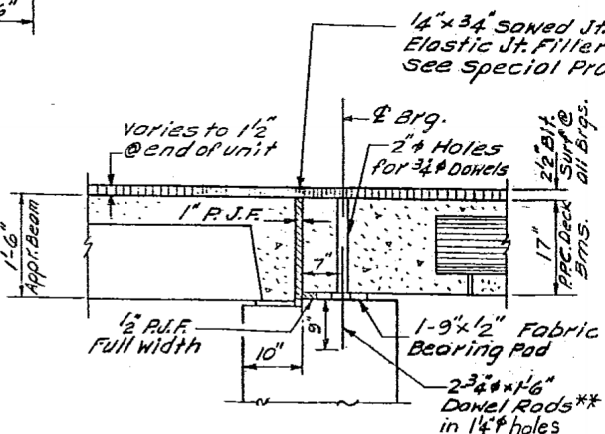

SECTION THRU ABUT. AT OUTSIDE BEAM

FOR INFORMATION ONLY

NOTES

Prestressing steel shall be non-galvanized high strength, stress-relieved 7-wire strand, Grade 270. The nominal diameter shall be 1/2" and the nominal cross-sectional area shall be 0.153 sq. in. Lifting loops shall be 1/2" diameter, 6 x 25 class wire rope with fiber core and shall have a minimum ultimate tensile strength of 21,000 lbs. or 1/2" - 270 ksi strands as shown.

Reinforcement bars shall conform to AASHTO: M-31 or M-53, Grade 60. The bearing seat surfaces shall be adjusted by shimming to assure firm and even bearing. Two 1/8" fabric adjusting shims of the dimensions of the Exterior Bearing Pad shall be provided for each bearing.

Key way surfaces shall be cleaned to remove form oil or other bond breaking materials prior to shipment of the beams. Cleaning shall be done by sandblasting the keyway areas between top of the beam and the bottom edge of key.

BILL OF MATERIAL

Bar	No.	Size	Length	Shape
Pre-cast Prestressed Concrete Deck Beams (17")		Sq Ft.	2500	

DECK BEAMS  
F.A. RT. 885 SEC. 112B-DR  
POPE COUNTY  
STA. 913+50.00

DESIGNED: [Signature] 1981  
CHECKED: [Signature]  
DRAWN: [Signature]  
CHECKED: BVG s-a-d

EXAMINED: [Signature] 1981  
PASSED: [Signature]  
APPROVED: [Signature]

DIRECTOR OF HIGHWAYS

PD-3-S 6-15-80



USER NAME = has	DESIGNED - JMS	REVISED -
ESCA PROJECT NO. 988.12	DRAWN - HAS	REVISED -
PLOT SCALE = 0.1667' / IN.	CHECKED - RDP	REVISED -
PLOT DATE = 8/2/2013 11:43:11 AM	DATE - 03/13	REVISED -

STATE OF ILLINOIS  
DEPARTMENT OF TRANSPORTATION

EXISTING STRUCTURE PLANS - FOR INFORMATION ONLY  
STRUCTURE NO. 076-0009

SCALE: SHEET NO. 3 OF 8 SHEETS STA. TO STA.

F.A.P. RTE. 885	SECTION 112B-1	COUNTY POPE	TOTAL SHEETS 56	SHEET NO. 46
CONTRACT NO. 78230			FED. ROAD DIST. NO. ILLINOIS FED. AID PROJECT AID	

STATE OF ILLINOIS  
DEPARTMENT OF TRANSPORTATION

ROUTE NO.	SECTION	COUNTY	TOTAL SHEETS	SHEET NO.
S.E.L. 885	112B-DR	POPE	16	12
FED. ROAD DIST. NO. 7	ILLINOIS	FED. AID PROJECT		

SHEET NO. 4  
8 SHEETS

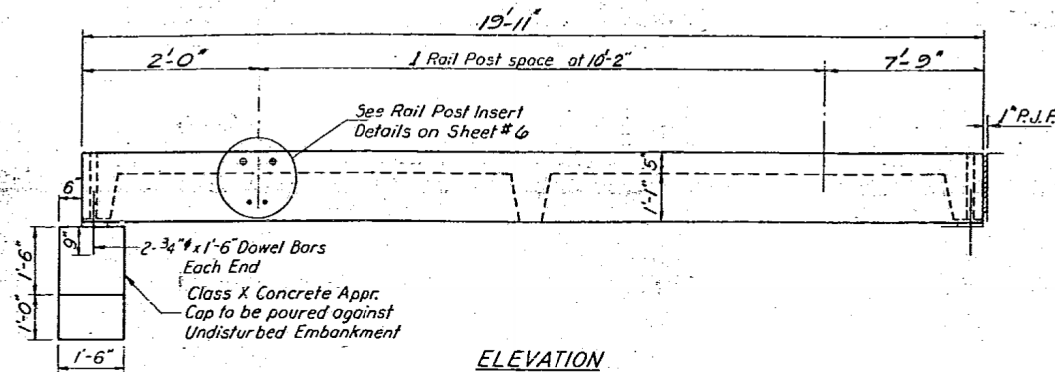

**ELEVATION**  
Note: Furnish 2 Right Hand Units & 2 Left Hand Units

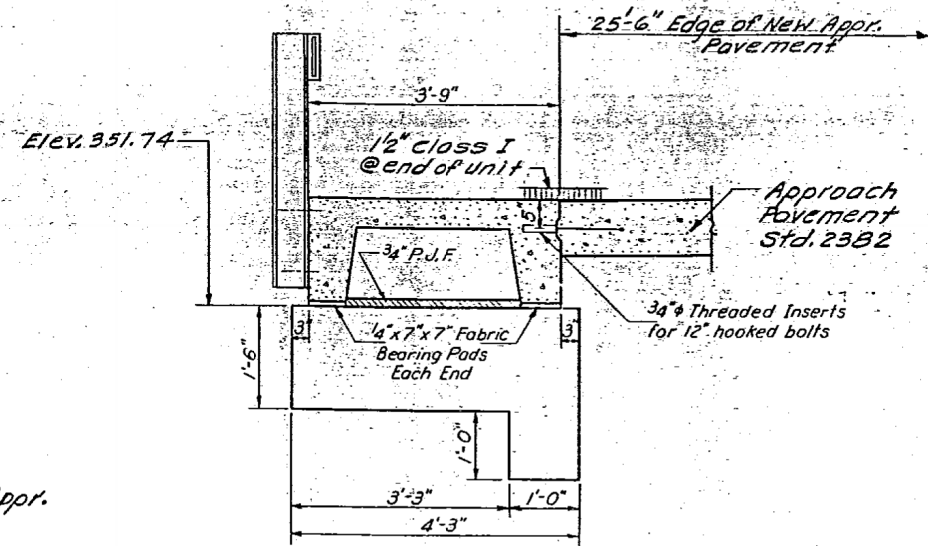

**SECTION A-A**

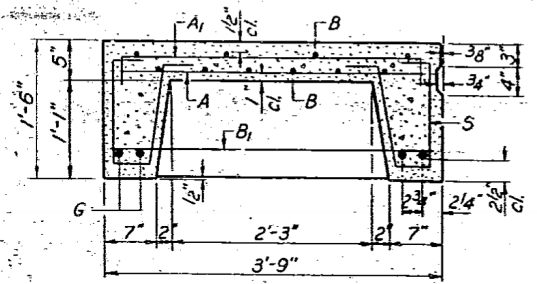

**SECTION THRU PRECAST UNIT**

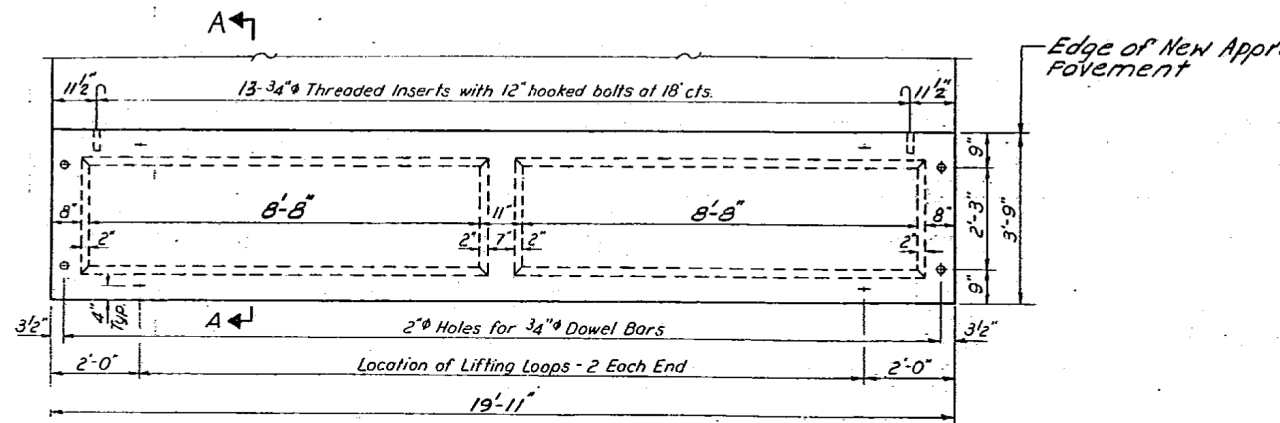

**PARTIAL PLAN OF APPROACH**

**BAR LIST - ONE UNIT**

Reinforcement to be cast into slab

Bar	No	Size	Length	Shape
A	52	#4	3'-3"	—
A <sub>1</sub>	26	#4	4'-0"	┌
B	10	#4	19'-6"	—
B <sub>1</sub>	6	#4	3'-6"	—
G	4	#10	19'-6"	—
S	42	#3	3'-4"	┌

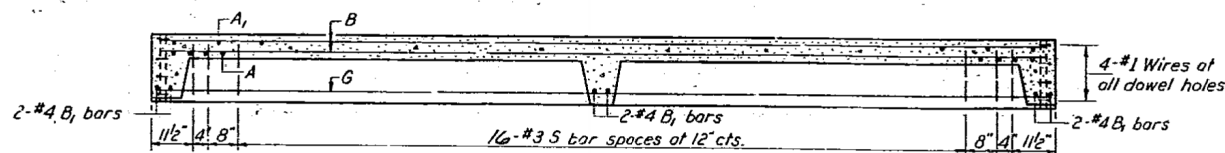
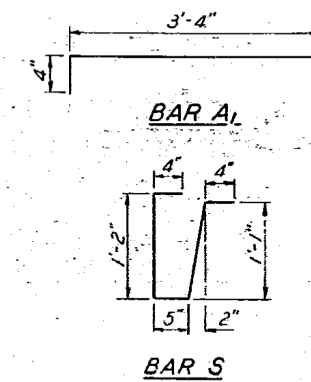

**LONGITUDINAL SECTION**

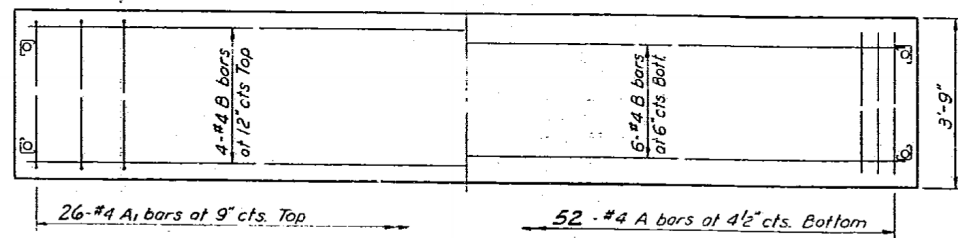

**SLAB REINFORCEMENT**

DESIGNED	Perman V. Davis
CHECKED	Shank Damm
DRAWN	SP
CHECKED	RVG SLD

EXAMINED	April 8 1981 Carl E. Hummer
PASSED	
APPROVED	

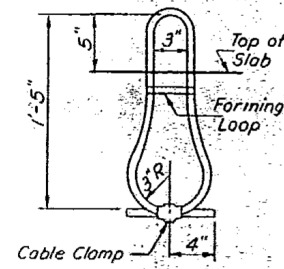

**LIFTING LOOP DETAIL**

**STRESSES**

f<sub>c</sub> = 4,500 psi.  
f<sub>c</sub> = 4,800 psi.  
f<sub>s</sub> = 20,000 psi.  
n = 8

LOADING HS-20

**APPROACH DETAILS**  
F.A. RT.885 SEC.112B-DR  
POPE COUNTY  
STA. 913+50.00

**4 UNITS  
BILL OF MATERIAL**

Item	Unit	Quantity
Precast Concrete Bridge Slab	Sq. Ft.	299
Class X Concrete	Cu. Yds.	1.6

FOR INFORMATION ONLY

STATE OF ILLINOIS  
DEPARTMENT OF TRANSPORTATION

EXISTING STRUCTURE PLANS - FOR INFORMATION ONLY  
STRUCTURE NO. 076-0009

SCALE: SHEET NO. 4 OF 8 SHEETS STA. TO STA.

F.A.P. RTE.	SECTION	COUNTY	TOTAL SHEETS	SHEET NO.
885	112B-1	POPE	56	47
CONTRACT NO. 78230			FED. ROAD DIST. NO. ILLINOIS FED. AID PROJECT AID	

AP-1 20' Precast Appr Unit (Rt 1) 4-15-71



USER NAME = has	DESIGNED - JMS	REVISED -
ESCA PROJECT NO. 988.12	DRAWN - HAS	REVISED -
PLOT SCALE = 0.1667' / IN.	CHECKED - RDP	REVISED -
PLOT DATE = 8/2/2013 11:43:44 AM	DATE - 03/13	REVISED -

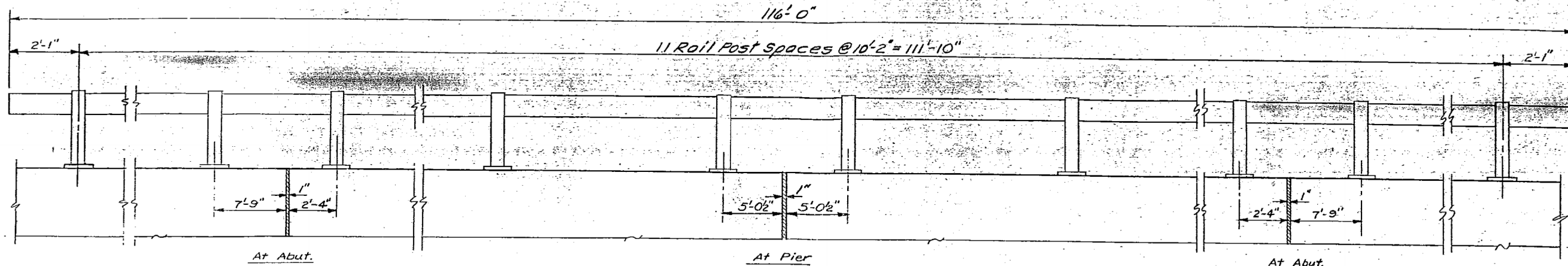

ELEVATION

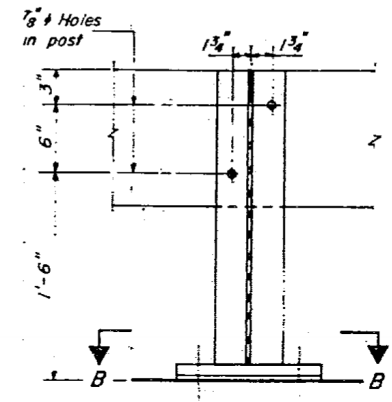

SECTION A-A

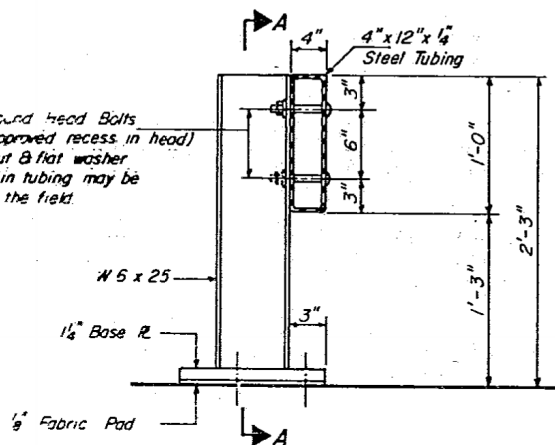

SECTION AT RAIL POST

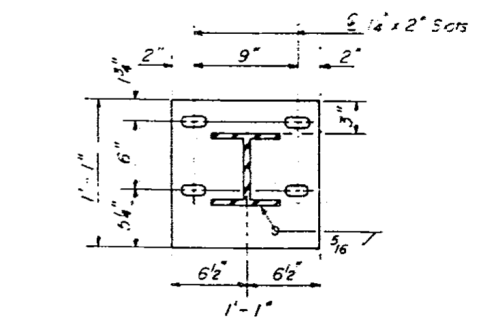

SECTION B-B

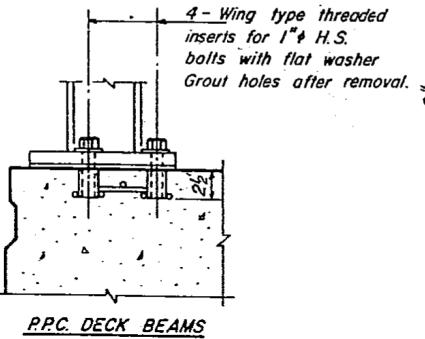

P.P.C. DECK BEAMS

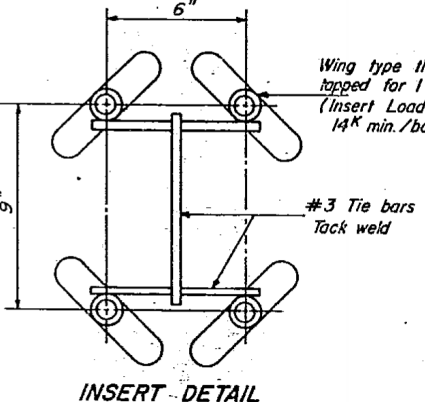

INSERT DETAIL

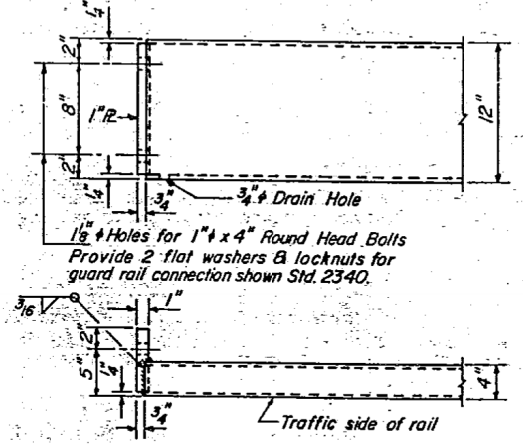

END OF RAIL DETAILS

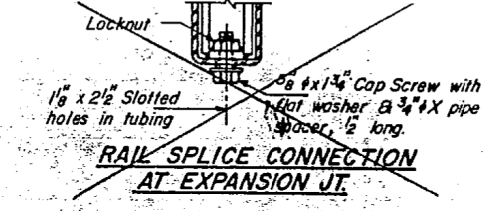

RAIL SPLICE CONNECTION AT EXPANSION JT.

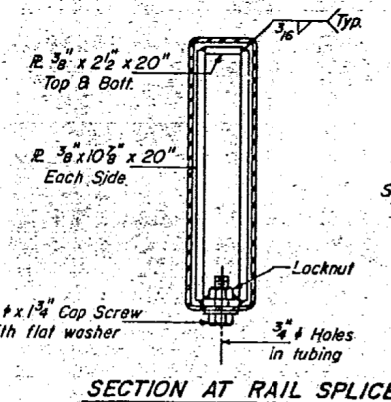

SECTION AT RAIL SPLICE

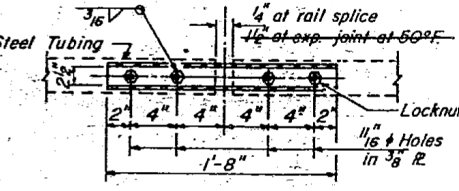

PLAN - BOTT. SPLICE PL. TYPICAL

**NOTES**

Hollow structural steel tubing shall conform to the requirements of A.S.T.M. designation A-500 Grade B Structural Steel Tubing.

All other steel shapes and plates shall conform to the requirements of A.A.S.H.T.O. M-163 except posts shall conform to A.A.S.H.T.O. M-223 Grade 50 Bolts; cap screws, and nuts shall conform to the requirement of ASTM designation A-307 except for high strength bolts, threaded rods, nuts and washers noted which shall conform to A.A.S.H.T.O. M-164.

The bridge rail shall receive one shop coat of a steel prime paint.

The 1" high strength bolts or threaded rods used to connect the railposts shall be tightened in accordance with Article 50704(g)(3) of the Standard Specification.

See Special Provisions for Temporary Bridge Rail.

**BILL OF MATERIAL**

Item	Unit	Quantity
Temporary Bridge Rail	Lin. Ft.	116

**TEMPORARY BRIDGE RAIL**  
F.A.R.T. 885 SEC. 112B-DR  
POPE COUNTY  
STA. 913+50.00

DESIGNED: Benjamin J. Boudie  
CHECKED: Steven K. Doern  
DRAWN: #  
CHECKED: SVG SKD

EXAMINED: April 8, 1981  
CAPT. E. Hummer  
PASSED  
APPROVED

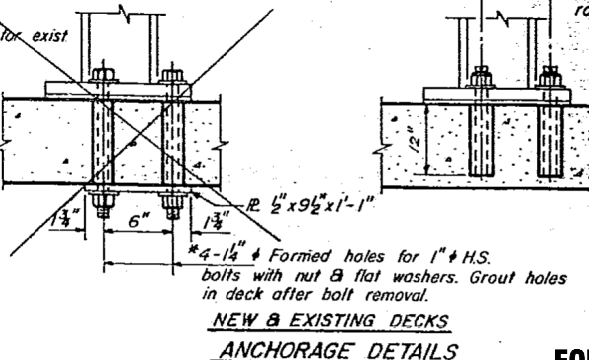

NEW & EXISTING DECKS  
ANCHORAGE DETAILS

FOR INFORMATION ONLY

R-25 8-30-80 10'-9" Maximum Post Spacing.  
Rev. 5-18-83 SKD



USER NAME = has	DESIGNED - JMS	REVISED -
ESCA PROJECT NO. 988.12	DRAWN - HAS	REVISED -
PLOT SCALE = 0.1667' / IN.	CHECKED - RDP	REVISED -
PLOT DATE = 8/2/2013 11:44:02 AM	DATE - 03/13	REVISED -

STATE OF ILLINOIS  
DEPARTMENT OF TRANSPORTATION

EXISTING STRUCTURE PLANS - FOR INFORMATION ONLY  
STRUCTURE NO. 076-0009

SCALE: SHEET NO. 5 OF 8 SHEETS STA. TO STA.

F.A.P. RTE.	SECTION	COUNTY	TOTAL SHEETS	SHEET NO.
885	112B-1	POPE	56	48
FED. ROAD DIST. NO.		ILLINOIS	FED. AID PROJECT AID	
		CONTRACT NO. 78230		



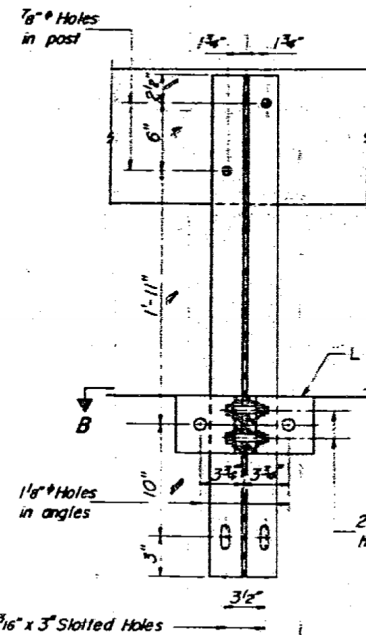
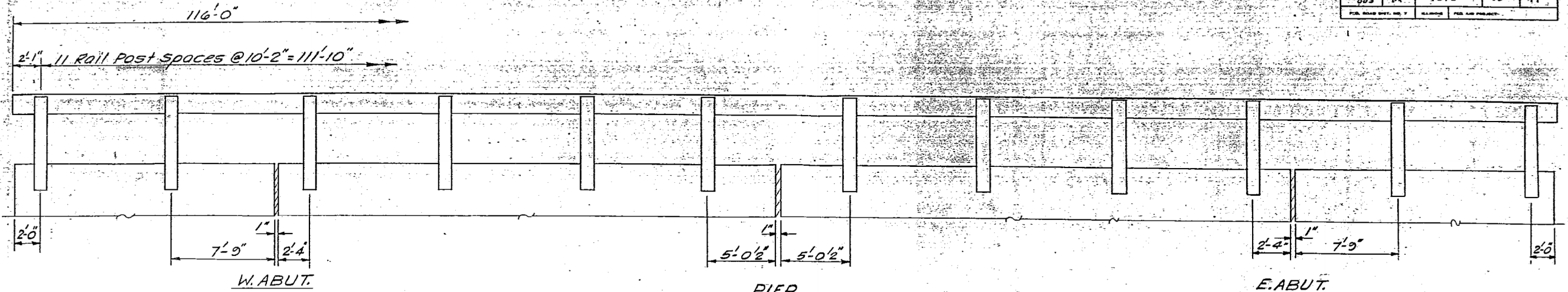

2-3/4" x 5" Round Head Bolts (With slot or approved recess in head) with locknut & flat washer 7/8" holes in tubing may be drilled in the field.

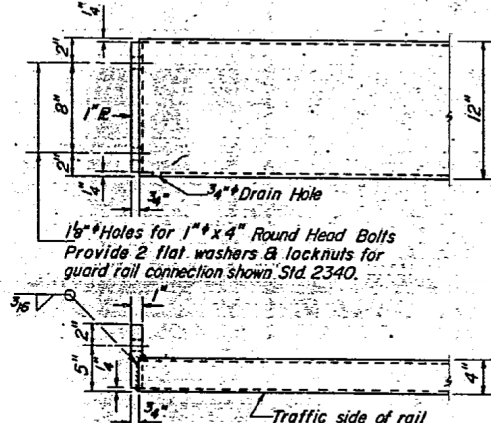
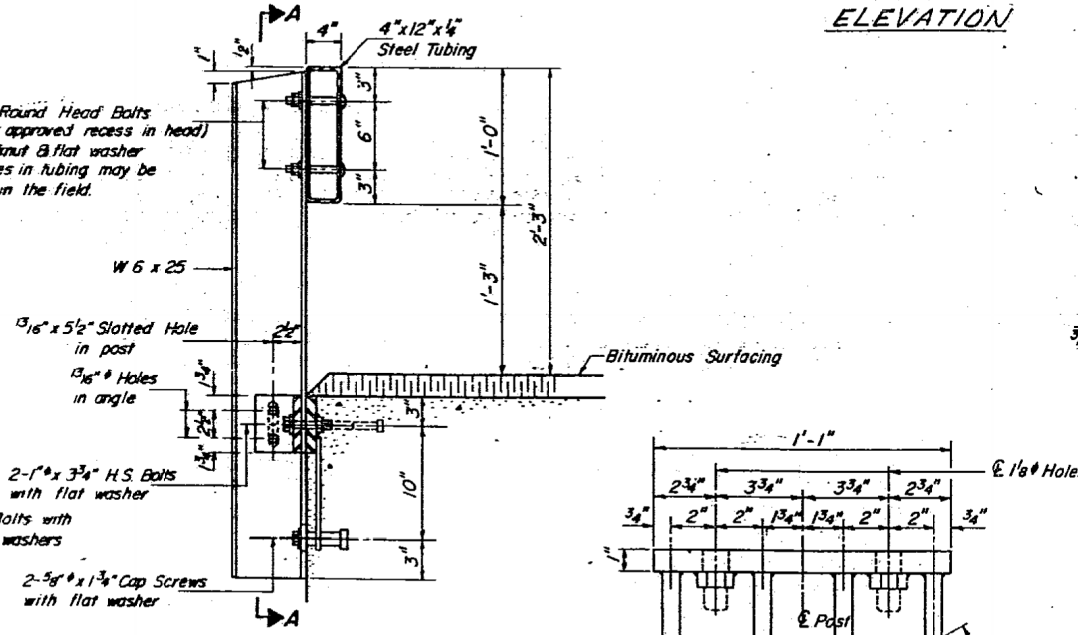

**NOTES**

Hollow structural steel tubing shall conform to the requirements of A.S.T.M. designation A-500 Grade B Structural Steel Tubing.

All other steel shapes and plates shall conform to the requirements of A.A.S.H.T.O. M-183 except posts and angles shall conform to A.A.S.H.T.O. M-223, Grade 50.

Bolts, cap screws, and nuts shall conform to the requirement of A.S.T.M. designation A-307 except for high strength bolts, nuts and washers noted which shall conform to A.A.S.H.T.O. M-164.

All bolts, nuts, cap screws, washers and lock washers shall be galvanized in accordance with A.A.S.H.T.O. M-232.

All posts, railing, rail splices, anchor devices and angles shall be galvanized after shop fabrication in accordance with A.A.S.H.T.O. M-111 and A.S.T.M. A-385. Galvanized rail shall not be painted.

Railing shall be in accordance with Section 508 of the Standard Specifications, except as noted, and shall be paid for at the contract unit price per linear foot for STEEL RAILING, TYPE S-1.

All field drilled holes shall be coated with an approved zinc rich paint before erection.

The lower portion of the post flange in contact with concrete shall receive two coats of asphalt paint conforming to Section 714.08 Type B or place 1/2" fabric bearing pad between the post and concrete.

The 3/4" high strength bolts used to connect the 6 x 4 x 3/4 angles to the post shall be tightened in accordance with Article 507.04(g)(3) of the Standard Specifications. The 1" high strength bolts connecting the angles to the concrete shall be tightened to a snug fit and given an additional 1/8 turn. The 5/8" cap screws in bottom of posts shall be tightened to a snug fit only.

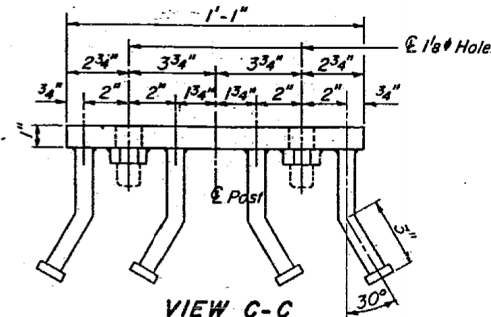

\*\* Whenever the lower insert assemblies interfere with strand locations, the #3 bars shall be cut and adjusted in order to allow raising or lowering of the lower inserts. Maximum adjustment not to exceed 1/2".

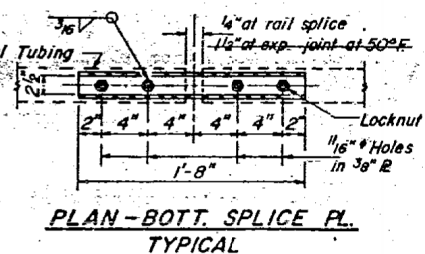
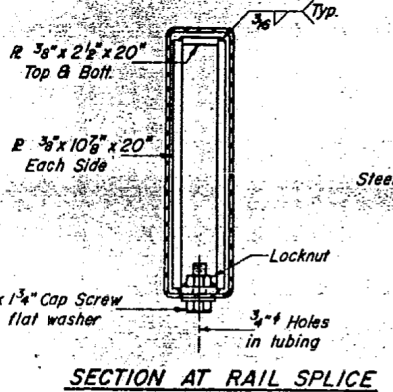
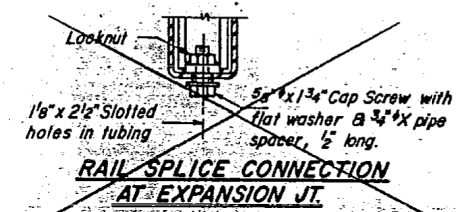
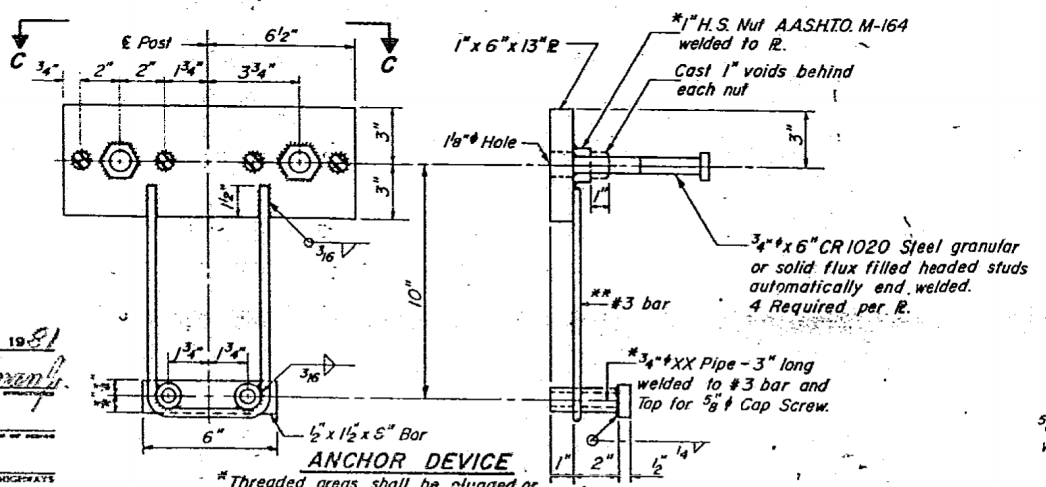
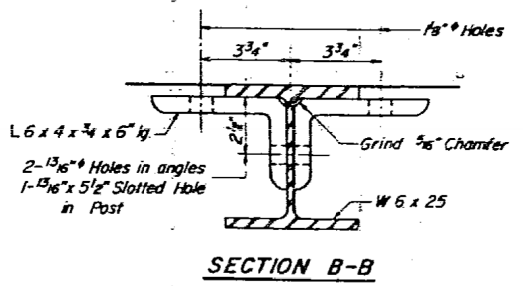

**BILL OF MATERIAL**

Item	Unit	Quantity
Steel Railing, Type S-1	Lin. Ft.	232

**TYPE S-1  
STEEL RAILING**  
F.A. RT. 885 SEC. 112 B-DR  
POPE COUNTY  
STA. 913+50.00

DESIGNED: *Boyan V. Hark*  
CHECKED: *Stuart Owen*  
DRAWN: *SA*  
CHECKED: *BVG*

APPROVED: *Carl E. Harman*  
DIRECTOR OF HIGHWAYS

APR 8 1981

R-23A 8-30-80 (10'-9" Maximum Post Spacing)

FOR INFORMATION ONLY

EXISTING STRUCTURE PLANS - FOR INFORMATION ONLY  
STRUCTURE NO. 076-0009

F.A.P. RTE.	SECTION	COUNTY	TOTAL SHEETS	SHEET NO.
885	112B-1	POPE	56	49
CONTRACT NO. 78230				
FED. ROAD DIST. NO. ILLINOIS FED. AID PROJECT AID				



USER NAME = has	DESIGNED - JMS	REVISED -
ESCA PROJECT NO. 988.12	DRAWN - HAS	REVISED -
PLOT SCALE = 0.1667 / IN.	CHECKED - RDP	REVISED -
PLOT DATE = 8/2/2013 11:44:20 AM	DATE - 03/13	REVISED -

STATE OF ILLINOIS  
DEPARTMENT OF TRANSPORTATION

SCALE: SHEET NO. 6 OF 8 SHEETS STA. TO STA.

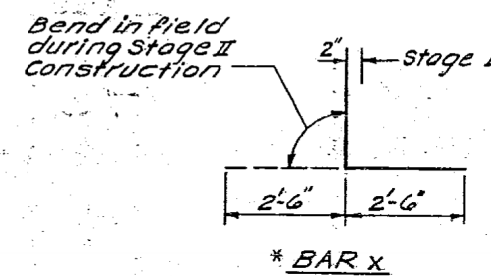
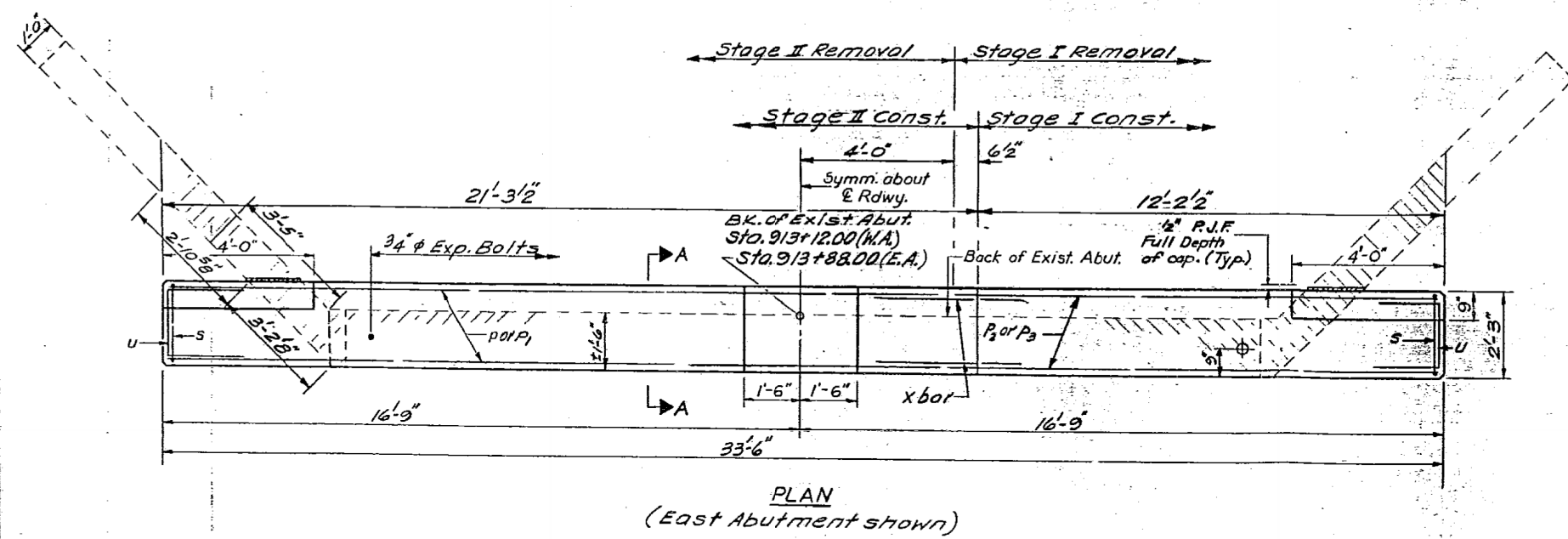
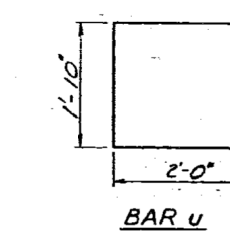
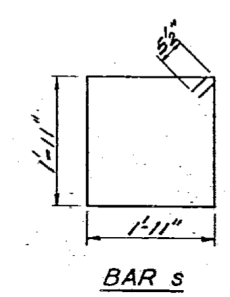
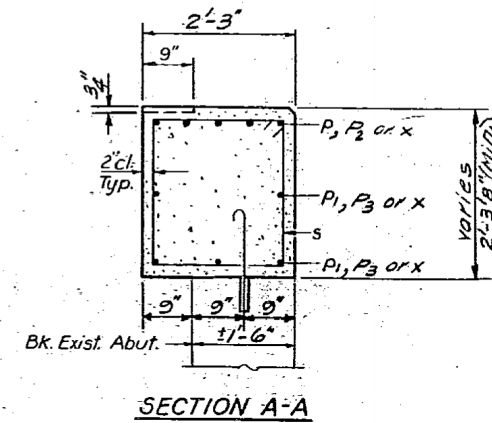
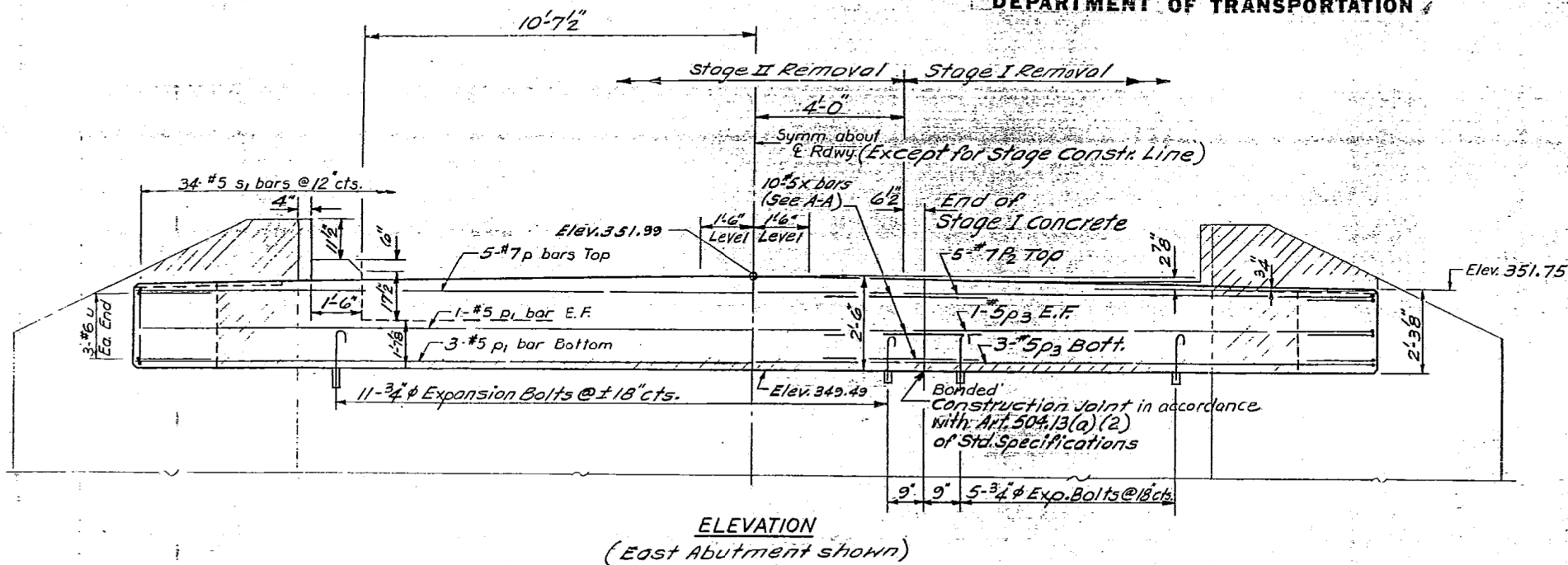

\* x bars shall conform to the requirements of AASHTO M31 or M53 Grade 40, except that the elongation shall not be less than 20%.

**TWO ABUTS.  
BILL OF MATERIAL**

Bar	No.	Size	Length	Shape
p	10	#7	21'-0"	—
p1	10	#5	21'-0"	—
p2	10	#7	12'-0"	—
p3	10	#5	12'-0"	—
S	68	#5	8'-6"	□
U	12	#6	5'-10"	└
X	20	#5	5'-0"	└
Class X Concrete			Cu.Yds.	19.3
Reinforcement Bars			Lbs	1830
Expansion Bolts 3/4"			Each	32
Concrete Removal			Cu.Yds.	8.0

**NOTE**  
Hatched area indicates Concrete Removal. Reinforcement extending into removed area shall be cleaned and incorporated into the new construction.  
Expansion bolts shall be anchored in sound concrete. All edges shall have standard 3/4" chamfers except as noted.

**ABUTMENTS**  
F.A. RT.885 SEC.112B-DR  
POPE COUNTY  
STA.913+50.00

DESIGNED: [Signature]  
CHECKED: [Signature]  
DRAWN: [Signature]  
CHECKED: [Signature]

EXAMINED: [Signature]  
PASSED: [Signature]  
APPROVED: [Signature]  
DIRECTOR OF HIGHWAYS

A-1 (5-15-71) Fixed Rev. 5-18-83 SKD

**FOR INFORMATION ONLY**



USER NAME = has	DESIGNED - JMS	REVISED -
ESCA PROJECT NO. 988.12	DRAWN - HAS	REVISED -
PLOT SCALE = 0.1667' / IN.	CHECKED - RDP	REVISED -
PLOT DATE = 8/2/2013 11:44:38 AM	DATE - 03/13	REVISED -

STATE OF ILLINOIS  
DEPARTMENT OF TRANSPORTATION

EXISTING STRUCTURE PLANS - FOR INFORMATION ONLY  
STRUCTURE NO. 076-0009

SCALE: SHEET NO. 7 OF 8 SHEETS STA. TO STA.

F.A.P. RTE.	SECTION	COUNTY	TOTAL SHEETS	SHEET NO.
885	112B-1	POPE	56	50
CONTRACT NO. 78230			FED. ROAD DIST. NO. ILLINOIS FED. AID PROJECT AID	

STATE OF ILLINOIS  
DEPARTMENT OF TRANSPORTATION

ROUTE NO.	SECTION	COUNTY	TOTAL SHEETS	SHEET NO.
112 B-C	DR	POPE	16	16
SHEET NO. 8 8 SHEETS				

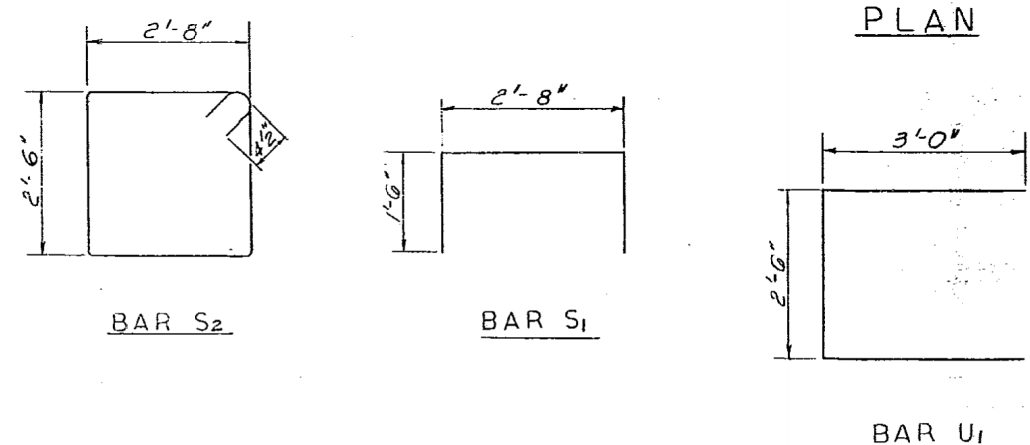
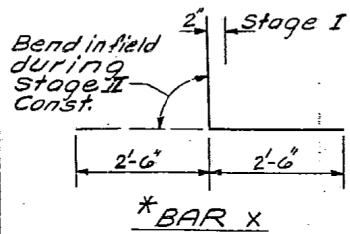
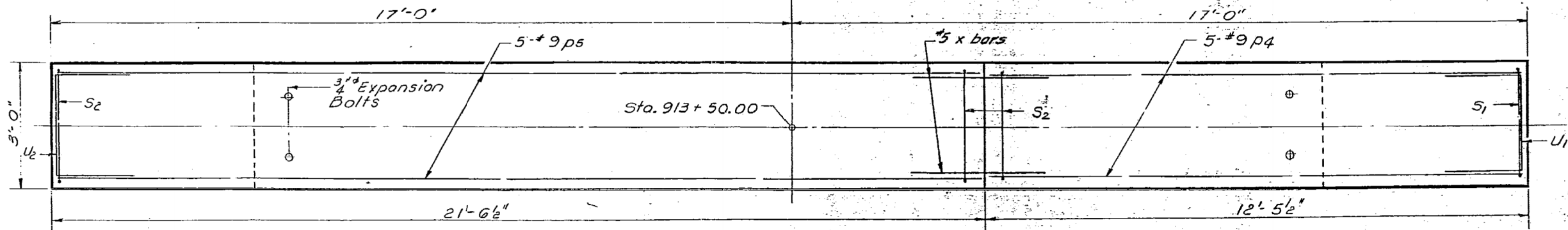
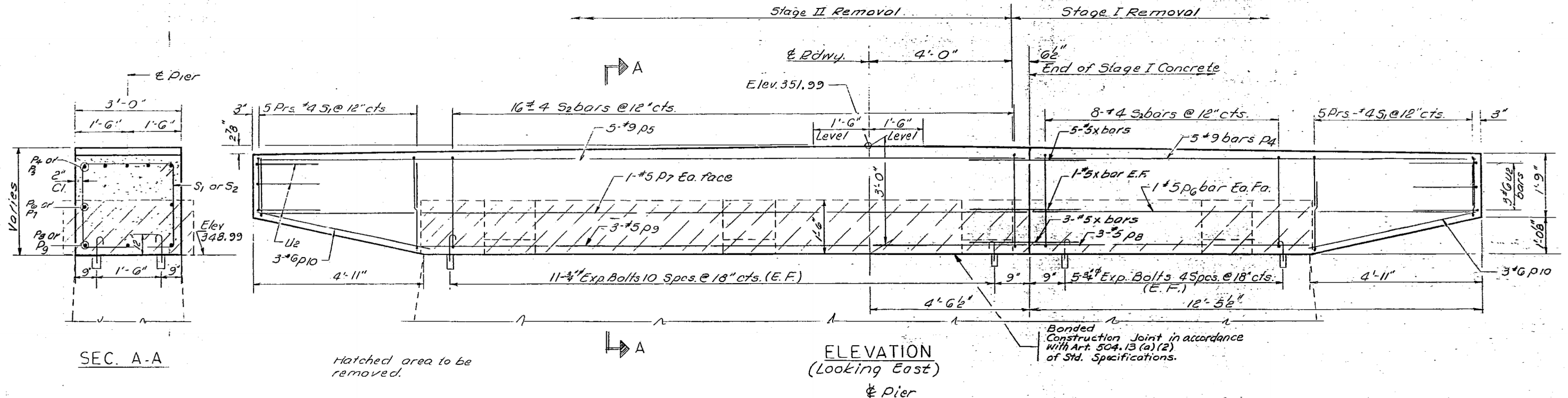

BILL OF MATERIAL

Bar No.	Size	Length	Shape
P4	5 #9	12'-3"	—
P5	5 #9	21'-3"	—
P6	2 #5	12'-3"	—
P7	2 #5	21'-3"	—
P8	3 #5	7'-6"	—
P9	3 #5	10'-6"	—
P10	6 #6	4'-9"	—
S1	20 #4	5'-8"	□
S2	24 #4	11'-1"	□
U1	6 #6	8'-6"	□
X	10 #5	5'-0"	—
Class I Concrete			Cu.Yds. 10.3
Reinforcement Bars			Lbs. 1140
Expansion Bolts 3/4"			Each 32
Concrete Removal			Cu.Yds. 4.2

PIER  
F.A. RT.885 SEC. 112 B-DR  
POPE COUNTY  
STA. 913 + 50.00

DESIGNED: F. Mercado  
CHECKED: A. Hernandez  
DRAWN: F. Mercado  
CHECKED: A. Hernandez  
EXAMINED: [Signature]  
PASSED: [Signature]  
APPROVED: [Signature]  
DIRECTOR OF HIGHWAYS

FOR INFORMATION ONLY



USER NAME = has	DESIGNED - JMS	REVISED -
ESCA PROJECT NO. 988.12	DRAWN - HAS	REVISED -
PLOT SCALE = 0.1667' / IN.	CHECKED - RDP	REVISED -
PLOT DATE = 8/2/2013 11:44:56 AM	DATE - 03/13	REVISED -

STATE OF ILLINOIS  
DEPARTMENT OF TRANSPORTATION

EXISTING STRUCTURE PLANS - FOR INFORMATION ONLY  
STRUCTURE NO. 076-0009  
SCALE: SHEET NO. 8 OF 8 SHEETS STA. TO STA.

F.A.P. RTE.	SECTION	COUNTY	TOTAL SHEETS	SHEET NO.
885	112B-1	POPE	56	51
CONTRACT NO. 78230				
FED. ROAD DIST. NO. ILLINOIS FED. AID PROJECT AID				

DATE \_\_\_\_\_ BY \_\_\_\_\_  
SURVEYED PLOTTED  
NOTE BOOK TEMPLATE  
AREAS AREAS  
CHECKED CHECKED  
NO. \_\_\_\_\_

DATE \_\_\_\_\_ BY \_\_\_\_\_  
SURVEYED PLOTTED  
NOTE BOOK TEMPLATE  
AREAS AREAS  
CHECKED CHECKED  
NO. \_\_\_\_\_

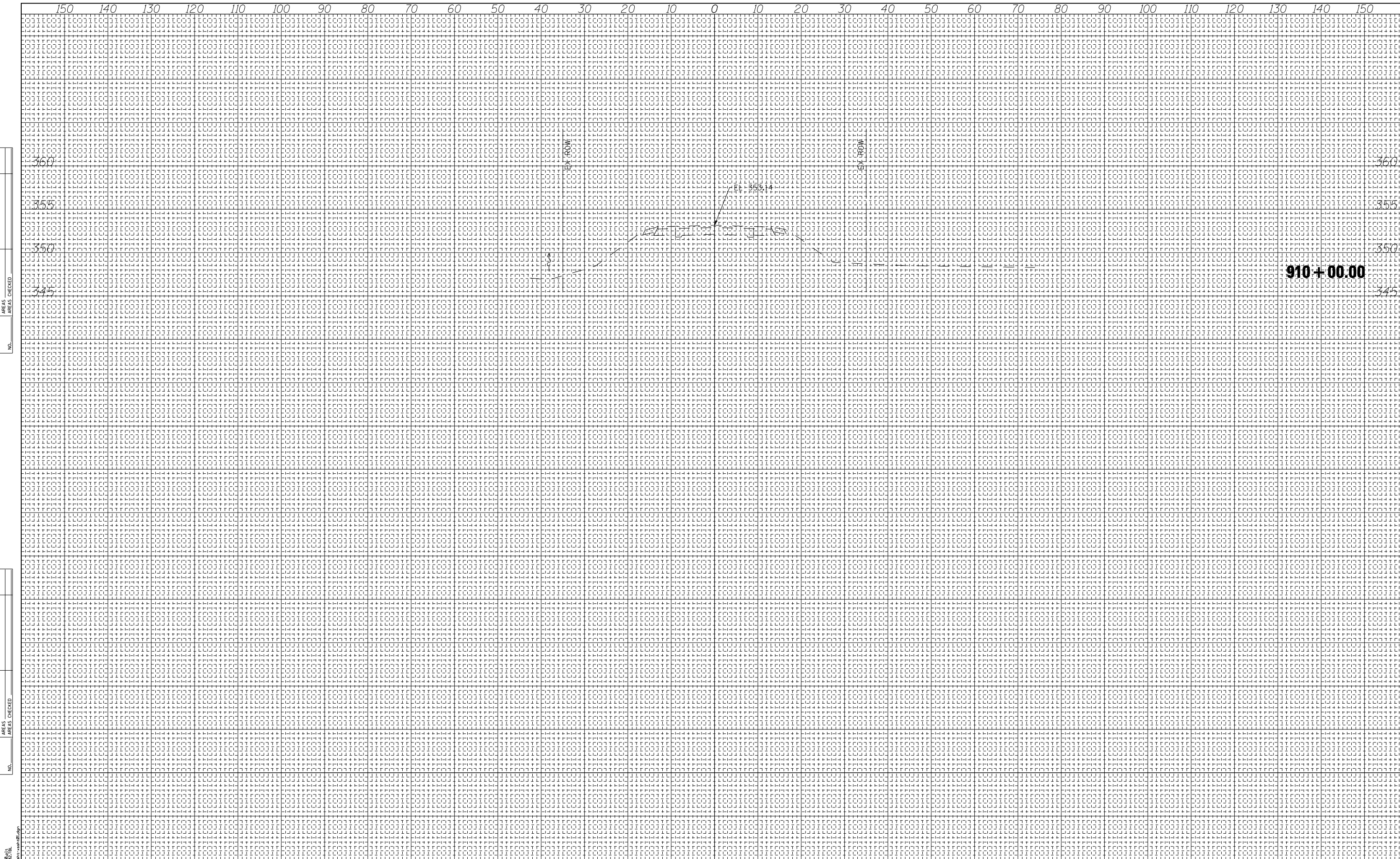

PRINT DRIVER: LDD\LB\B...  
SCALE: AS SHOWN

**ESCA CONSULTANTS, INC.**  
 ESCA PROJECT NO. 988.07  
 SCALES: (HORIZ) 1"=20' (VERT) 1"=5'  
 PLOT DATE = 8/2/2013 11:48:50 AM

DESIGNED - JMS	REVISED -
DRAWN - RJT/HAS	REVISED -
CHECKED - RDP	REVISED -
DATE - 03/13	REVISED -

**STATE OF ILLINOIS  
DEPARTMENT OF TRANSPORTATION**

**FAP 885 (IL 146) CROSS SECTIONS**

SCALE: AS SHOWN    SHEET NO. 1 OF 5 SHEETS    STA. 908+24.00 TO STA. 910+00.00

F.A.P. RTE. 885	SECTION 112B-1	COUNTY POPE	TOTAL SHEETS 56	SHEET NO. 52
CONTRACT NO. 78230				
FED. ROAD DIST. NO. 9 ILLINOIS FED. AID PROJECT AID				

DATE	
BY	
FINAL SURVEY NO.	
SURVEYED PLOTTED TEMPLATE AREAS CHECKED	
NOTE BOOK NO.	

DATE	
BY	
ORIGINAL SURVEY NO.	
SURVEYED PLOTTED TEMPLATE AREAS CHECKED	
NOTE BOOK NO.	

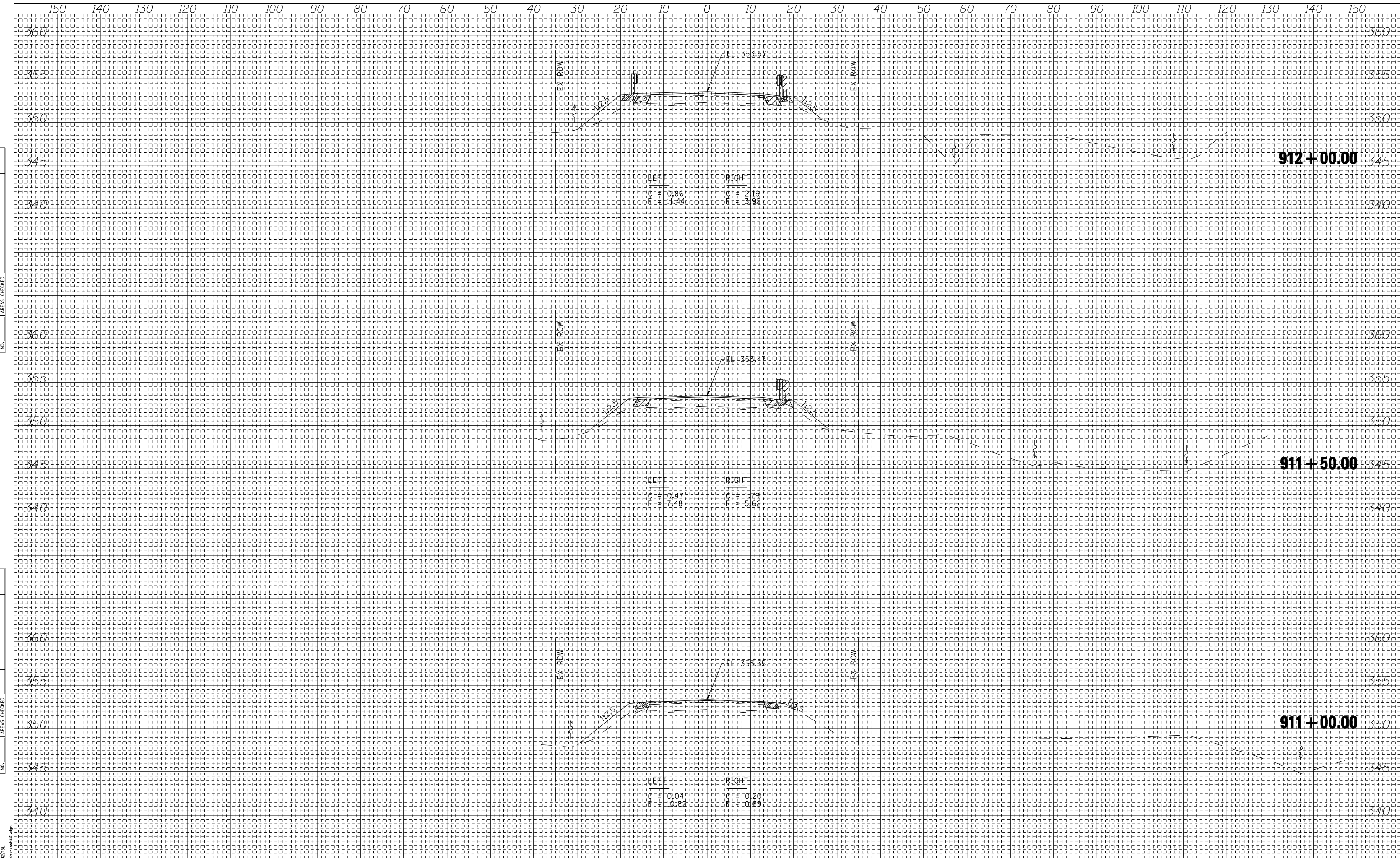

USER NAME = has	DESIGNED - JMS	REVISED -
ESCA PROJECT NO. 988.07	DRAWN - RJT/HAS	REVISED -
SCALES: (HORIZ) 1"=20' (VERT) 1"=5'	CHECKED - RDP	REVISED -
PLOT DATE = 8/2/2013 11:49:13 AM	DATE - 03/13	REVISED -

**STATE OF ILLINOIS  
DEPARTMENT OF TRANSPORTATION**

**FAP 885 (IL 146) CROSS SECTIONS**

SCALE: AS SHOWN    SHEET NO. 2 OF 5 SHEETS    STA. 911+00.00 TO STA. 912+00.00

F.A.P. RTE.	SECTION	COUNTY	TOTAL SHEETS	SHEET NO.
885	112B-1	POPE	56	53
CONTRACT NO. 78230				

FED. ROAD DIST. NO. 9 ILLINOIS FED. AID PROJECT AID

DATE	BY

DATE	BY

NO.	AREAS CHECKED	TEMPLATE	PLOTTED	SURVEYED	ORIGINAL SURVEY

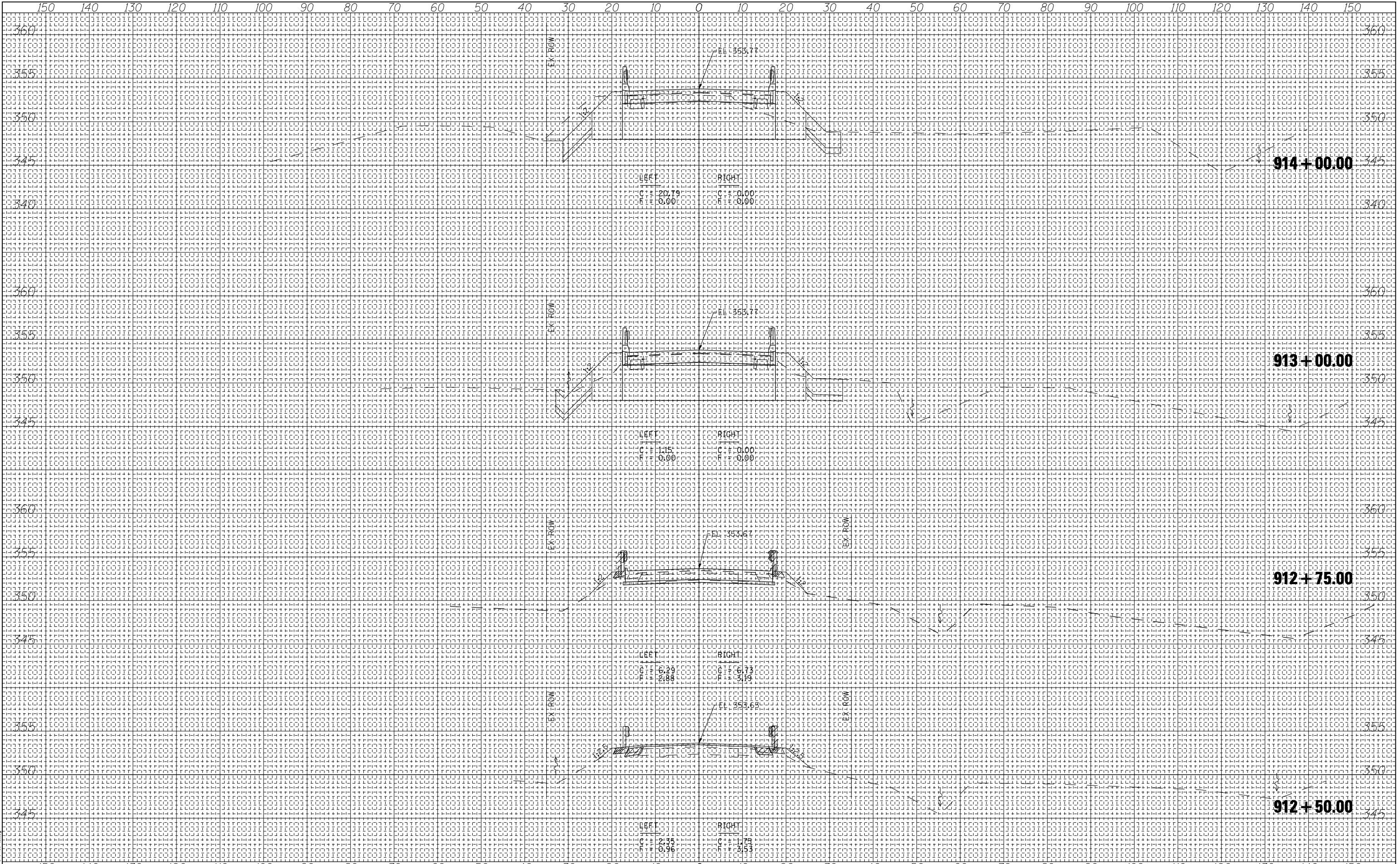

USER NAME = has	DESIGNED - JMS	REVISED -
ESCA PROJECT NO. 988.07	DRAWN - RJT/HAS	REVISED -
SCALES: (HORIZ) 1"=20' (VERT) 1"=5'	CHECKED - RDP	REVISED -
PLOT DATE = 8/2/2013 11:49:32 AM	DATE - 03/13	REVISED -

**STATE OF ILLINOIS  
DEPARTMENT OF TRANSPORTATION**

**FAP 885 (IL 146) CROSS SECTIONS**

SCALE: AS SHOWN    SHEET NO. 3 OF 5 SHEETS    STA. 912+50.00 TO STA. 914+00.00

F.A.P. RTE.	SECTION	COUNTY	TOTAL SHEETS	SHEET NO.
885	112B-1	POPE	56	54
CONTRACT NO.			78230	
FED. ROAD DIST. NO. 9 ILLINOIS FED. AID PROJECT AID				

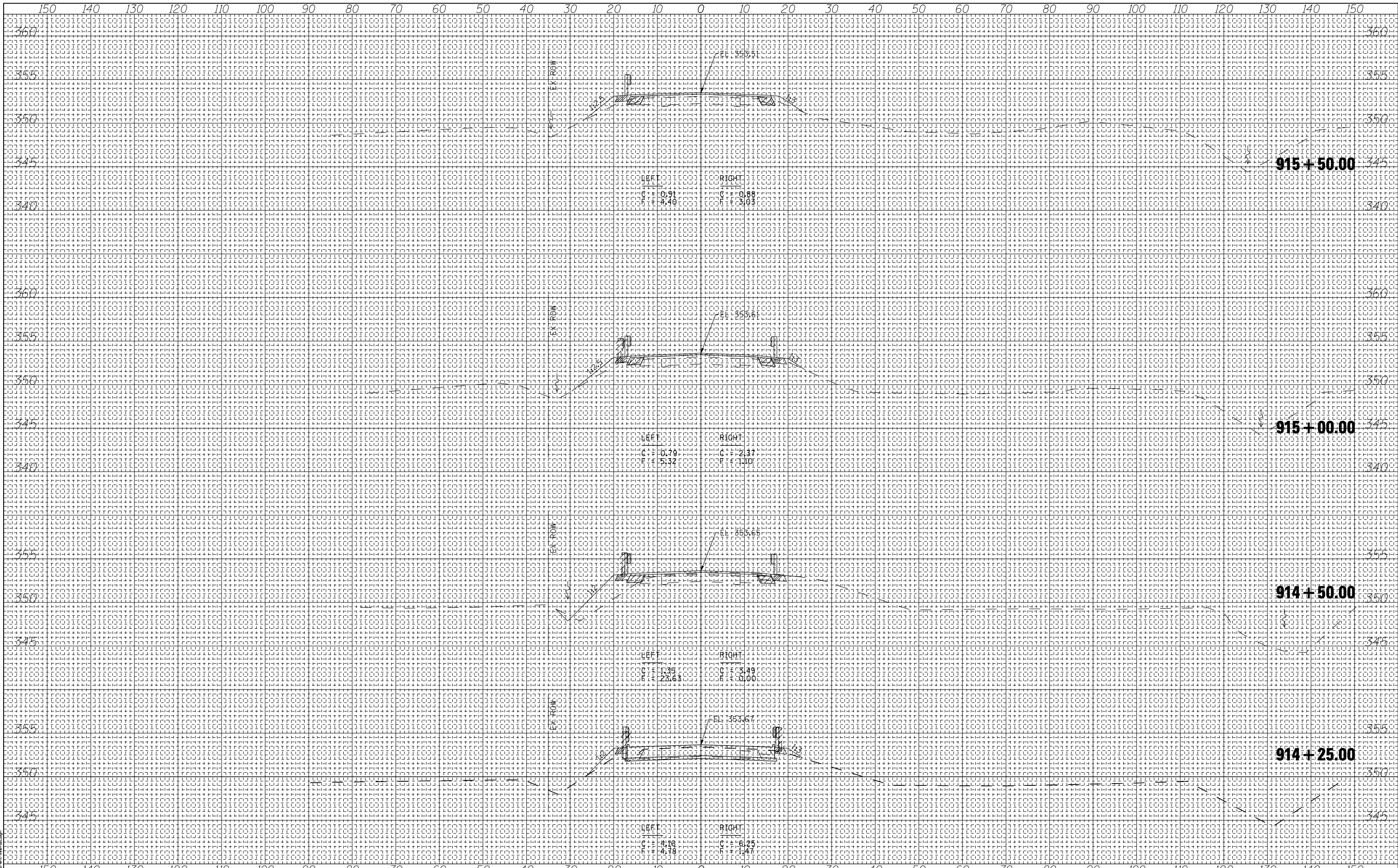

DATE: \_\_\_\_\_  
 BY: \_\_\_\_\_  
 SURVEYED PLOTTED TEMPLATE AREAS CHECKED  
 FINAL SURVEY NOTE BOOK NO. \_\_\_\_\_

DATE: \_\_\_\_\_  
 BY: \_\_\_\_\_  
 SURVEYED PLOTTED TEMPLATE AREAS CHECKED  
 ORIGINAL SURVEY NOTE BOOK NO. \_\_\_\_\_

PRINT DRIVER: L:\DLS\B\B\011...  
 FILE NAME: 1114951.dwg  
 DATE: 8/2/2013 11:49:51 AM



USER NAME = hos	DESIGNED - JMS	REVISED -
ESCA PROJECT NO. 988.07	DRAWN - RJT/HAS	REVISED -
SCALEs: (HORIZ) 1"=20' (VERT) 1"=5'	CHECKED - RDP	REVISED -
PLOT DATE = 8/2/2013 11:49:51 AM	DATE - 03/13	REVISED -

**STATE OF ILLINOIS  
 DEPARTMENT OF TRANSPORTATION**

**FAP 885 (IL 146) CROSS SECTIONS**

SCALE: AS SHOWN SHEET NO. 4 OF 5 SHEETS STA. 914+50.00 TO STA. 915+50.00

F.A.P. RTE.	SECTION	COUNTY	TOTAL SHEETS	SHEET NO.
885	112B-1	POPE	56	55
CONTRACT NO. 78230				
FED. ROAD DIST. NO. 9 ILLINOIS FED. AID PROJECT AID				

DATE	BY
NO.	NO.
AREAS CHECKED	AREAS CHECKED
TEMPLATE	TEMPLATE
NOTE BOOK	NOTE BOOK
SURVEYED	SURVEYED
PLOTTED	PLOTTED
FINAL SURVEY	FINAL SURVEY

DATE	BY
NO.	NO.
AREAS CHECKED	AREAS CHECKED
TEMPLATE	TEMPLATE
NOTE BOOK	NOTE BOOK
SURVEYED	SURVEYED
PLOTTED	PLOTTED
ORIGINAL SURVEY	ORIGINAL SURVEY

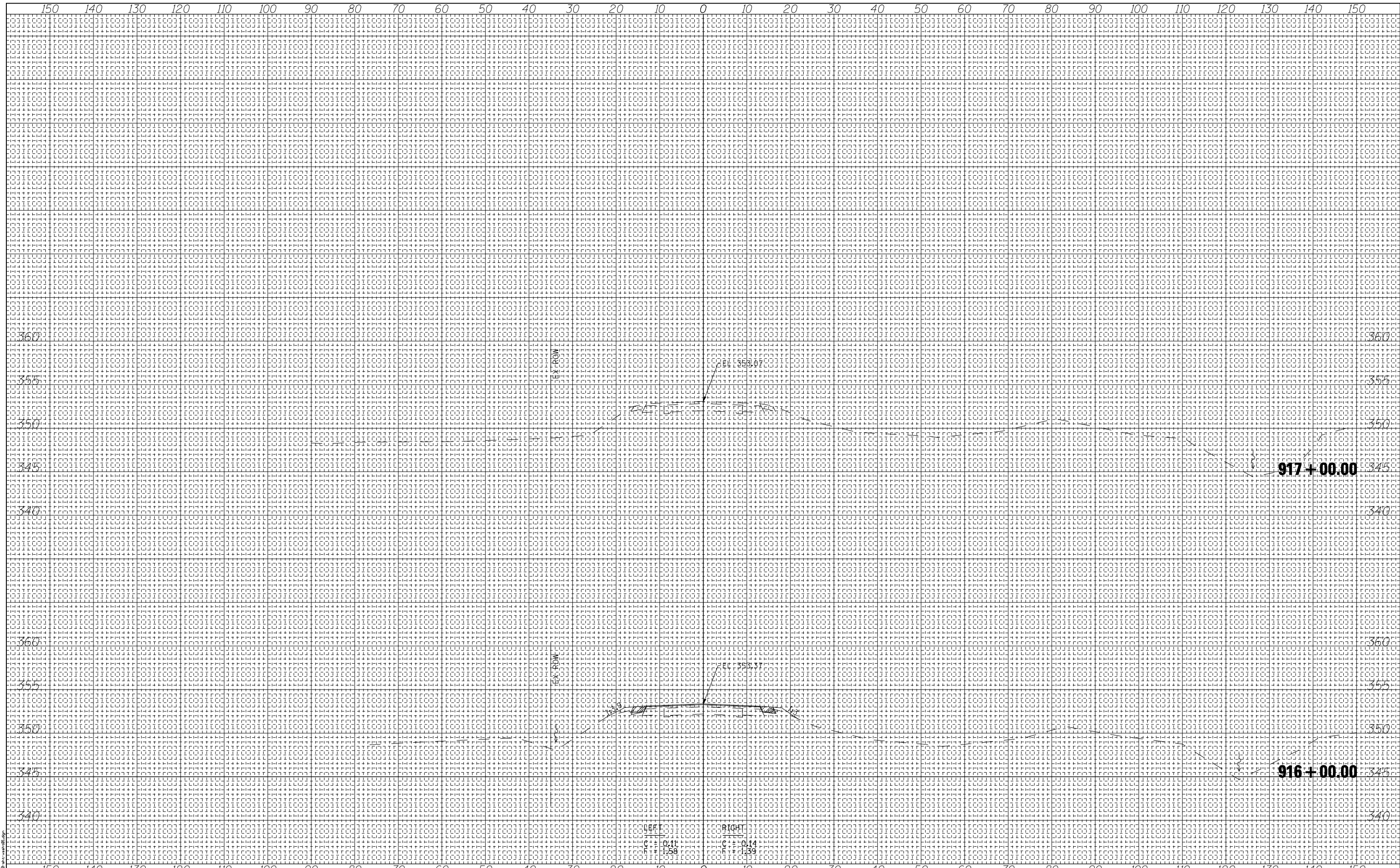

USER NAME = hos  
 ESCA PROJECT NO. 988.07  
 SCALES: (HORIZ) 1"=20' (VERT) 1"=5'  
 PLOT DATE = 8/2/2013 11:50:08 AM

DESIGNED - JMS  
 DRAWN - RJT/HAS  
 CHECKED - RDP  
 DATE - 03/13

REVISIONS:  
 REVISION -  
 REVISION -  
 REVISION -  
 REVISION -

**STATE OF ILLINOIS**  
**DEPARTMENT OF TRANSPORTATION**

**FAP 885 (IL 146) CROSS SECTIONS**

SCALE: AS SHOWN SHEET NO. 5 OF 5 SHEETS STA. 916+00.00 TO STA. 918+00.00

F.A.P. RTE.	SECTION	COUNTY	TOTAL SHEETS	SHEET NO.
885	112B-1	POPE	56	56
CONTRACT NO. 78230				
FED. ROAD DIST. NO. 9 ILLINOIS FED. AID PROJECT AID				