

| A | B | C | HEIGHT | WEIGHT |
|--------|-----------------|----------------|----------------------------|-----------------|
| VARIES | 9.5\" (241mm) | 19\" (483mm) | 7\" (178mm) - 12\" (300mm) | 53 lbs (24kg) |
| VARIES | 10.75\" (273mm) | 21.5\" (546mm) | 7\" (178mm) - 12\" (300mm) | 68 lbs (31 kg) |
| VARIES | 13.0\" (330mm) | 26\" (660mm) | 7\" (178mm) - 12\" (300mm) | 81 lbs (37 kg) |
| VARIES | 18.5\" (470mm) | 37\" (940mm) | 7\" (178mm) - 12\" (300mm) | 126 lbs (57 kg) |

NOTES:

- DIMENSION "A" IS EQUAL TO THE DIAMETER OF THE MAST ARM POLE AT THE TOP OF THE SHROUD. THE SHROUD SHALL BE TIGHT TO THE MAST ARM POLE.
- THE SUPPLIER SHALL VERIFY THE ABOVE DIMENSIONS BASED ON MAST ARM REQUIREMENTS.
- THE HEIGHT OF THE SHROUD SHALL COVER THE ANCHOR BOLTS, NUTS AND MAST ARM POLE BASE.

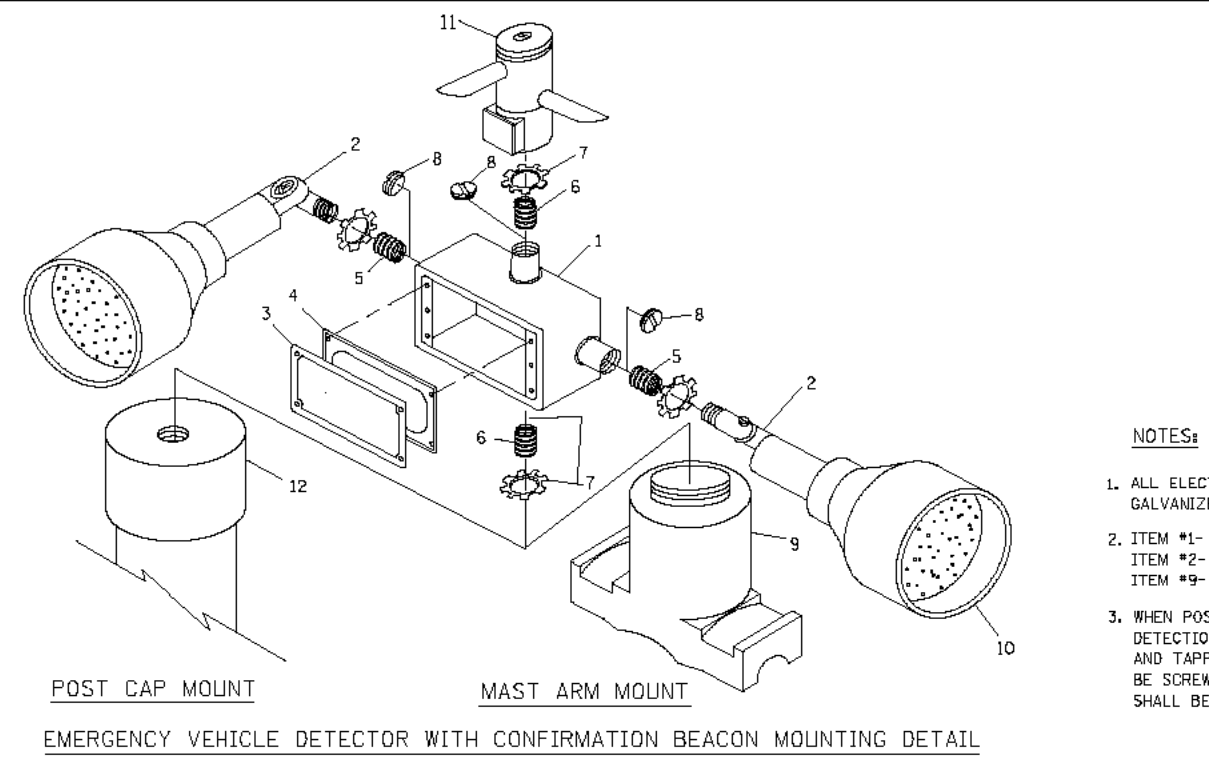
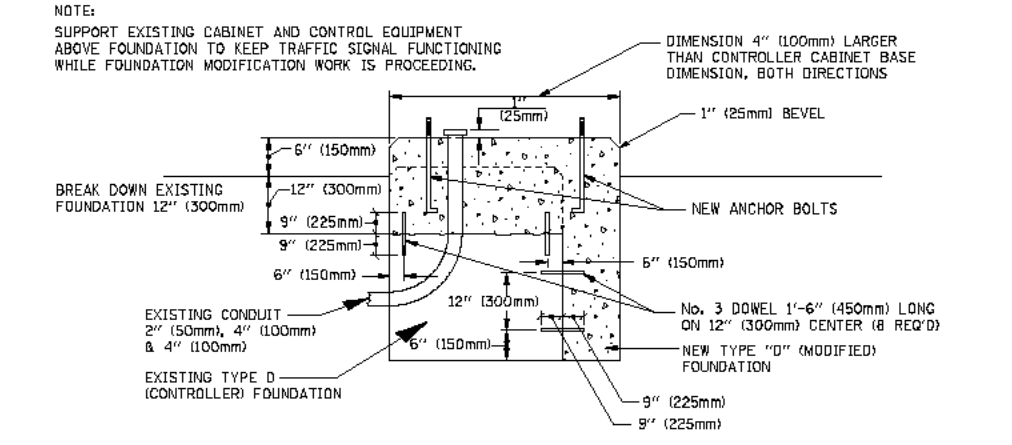

| ITEM NO. | IDENTIFICATION |
|----------|---|
| 1 | OUTLET BOX- GALV. 21 CU.IN. (0.000344 CU-M) |
| 2 | LAMP HOLDER AND COVER |
| 3 | OUTLET BOX COVER |
| 4 | RUBBER COVER GASKET |
| 5 | REDUCING BUSHING |
| 6 | 3/4\" (19 mm) CLOSE NIPPLE |
| 7 | 3/4\" (19 mm) LOCKNUT |
| 8 | 3/4\" (19 mm) HOLE PLUG |
| 9 | SADDLE BRACKET - GALV. |
| 10 | 6 WATT PAR 38 LED FLOOD LAMP |
| 11 | DETECTOR UNIT |
| 12 | POST CAP (18 FT. (5.4 m) POST MIN.) |

NOTES:

- ALL ELECTRICAL ITEMS, EXCEPT ITEMS #2 AND #11 SHALL BE ALUMINUM OR GALVANIZED
- ITEM #1- 02/GEDNEY FSX-1-50 OR EQUIVALENT
ITEM #2- MULBERRY CON-O-SHADE LAMP SHIELD OR EQUIVALENT
ITEM #9- "BAND-IT" SADDLE BRACKET OR EQUIVALENT
- WHEN POST MOUNTING IS SPECIFIED, ITEM #9 SHALL NOT BE REQUIRED. THE DETECTION UNIT SHALL BE MOUNTED DIRECTLY ON TOP OF THE CAP BY DRILLING AND TAPPING A 3/4\" (19 mm) HOLE WITH PIPE THREADS. THE POST CAP SHALL EITHER BE SCREWED TO THE TOP OF THE POST OR A MINIMUM OF 3 TIGHTENING SCREWS SHALL BE REQUIRED ON EACH CAP.

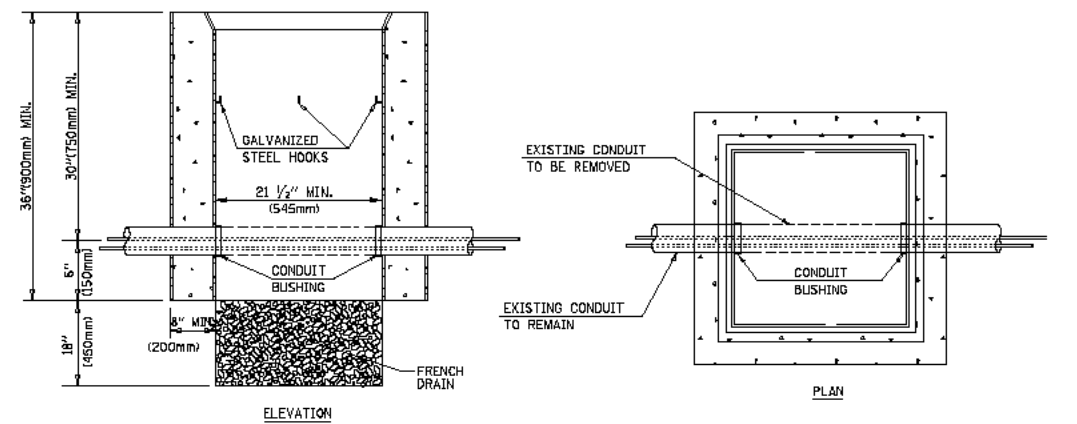

NOTES:

- HANDHOLE CONSTRUCTED PER STATE STANDARD 814001.
- REMOVAL OF THE EXISTING CONDUIT FROM THE HANDHOLE AND THE INSTALLATION OF THE CONDUIT BUSHINGS SHALL BE INCIDENTAL TO THE HANDHOLE.

| | | | |
|--|----------------------------|-----------------|-----------|
| FILE NAME = | USER NAME = kenthaphixaybo | DESIGNED - DAG | REVISED - |
| or\work\p\1001\KANTHAPHIXAYBO\101264\trf\Fis_Legend.v7.dgn | | DRAWN - BCK | REVISED - |
| | | CHECKED - DAD | REVISED - |
| | | DATE - 10/28/09 | REVISED - |

**STATE OF ILLINOIS
DEPARTMENT OF TRANSPORTATION**

DISTRICT 1
STANDARD TRAFFIC SIGNAL DESIGN DETAILS

| | | | | |
|---------------------|---------|--------|---------------------------|-----------|
| F.A.P. R.T.E. | SECTION | COUNTY | TOTAL SHEETS | SHEET NO. |
| 870 | 534R-B | DuPAGE | 53 | 23 |
| FED. ROAD DIST. NO. | | | ILLINOIS FED. AID PROJECT | |