

* Verify before drilling holes in mounting tube and cross tubes.

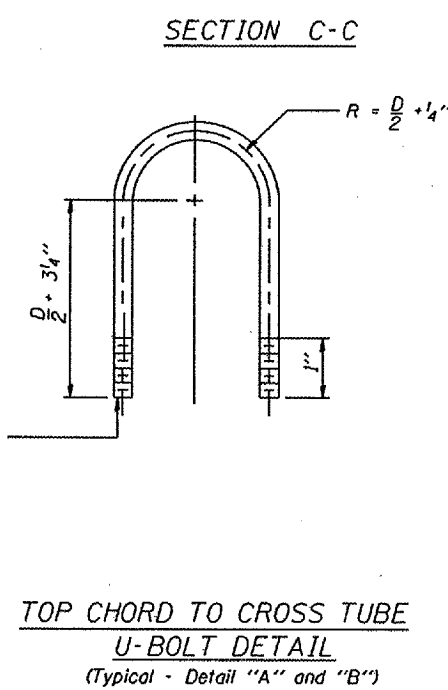
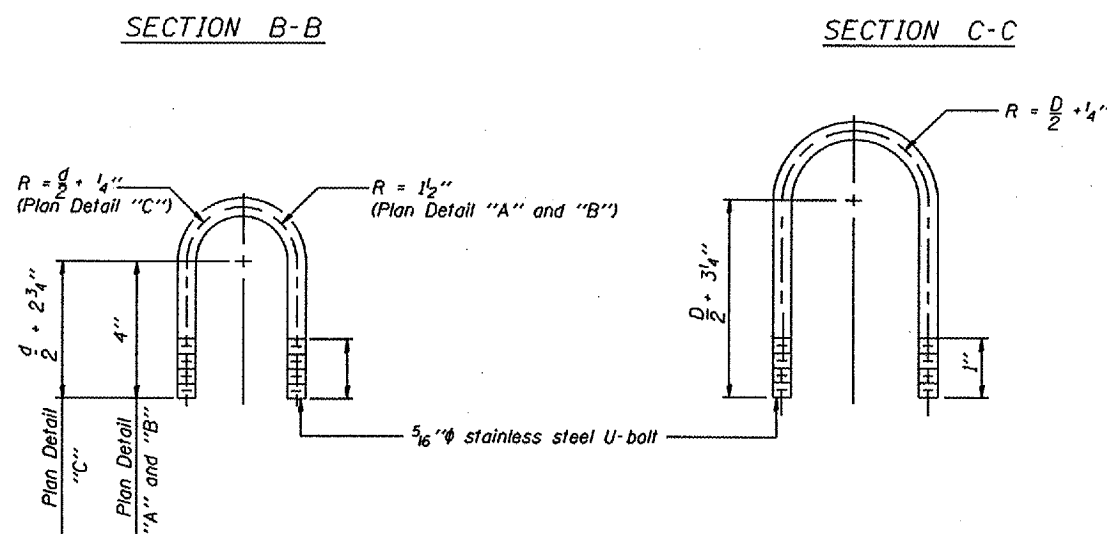
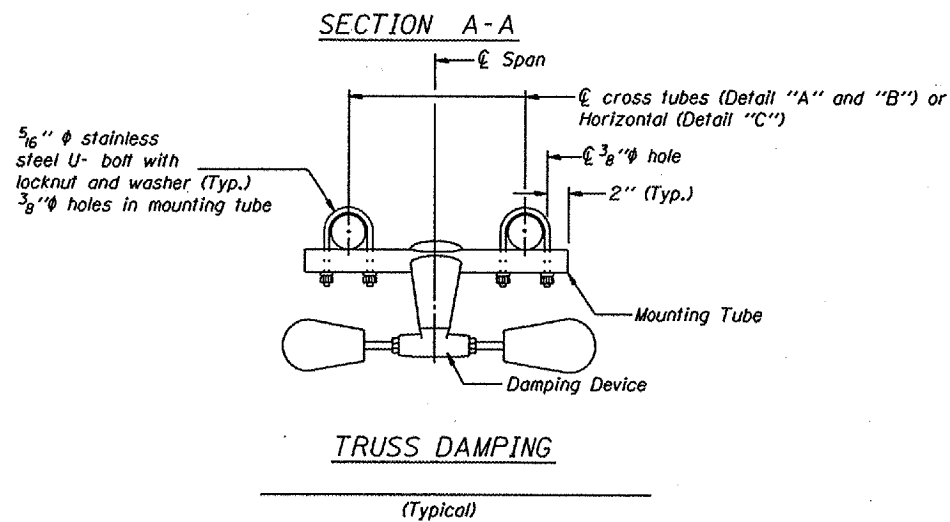
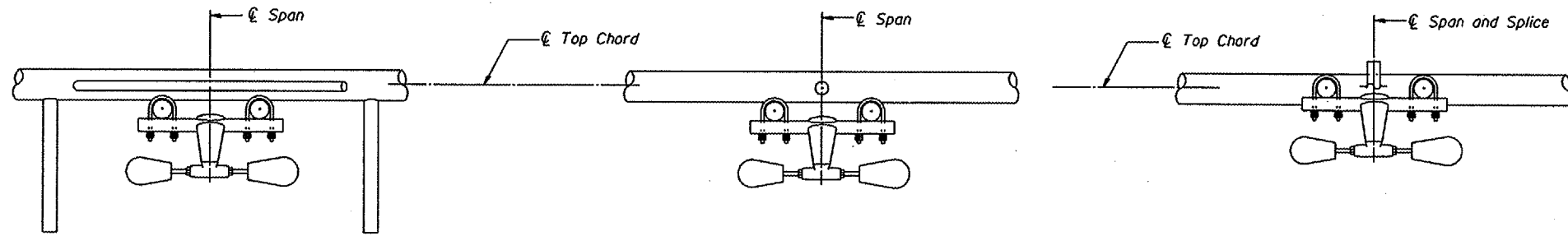
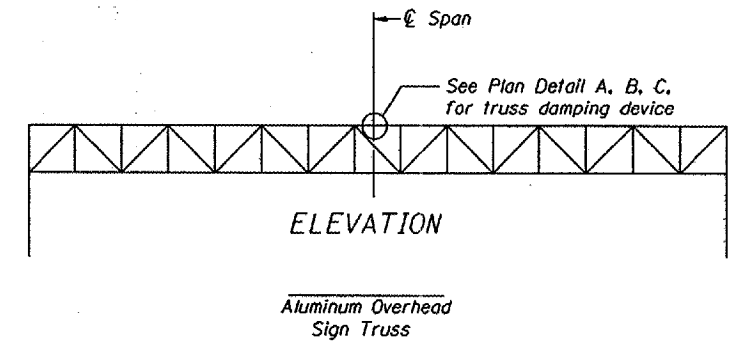
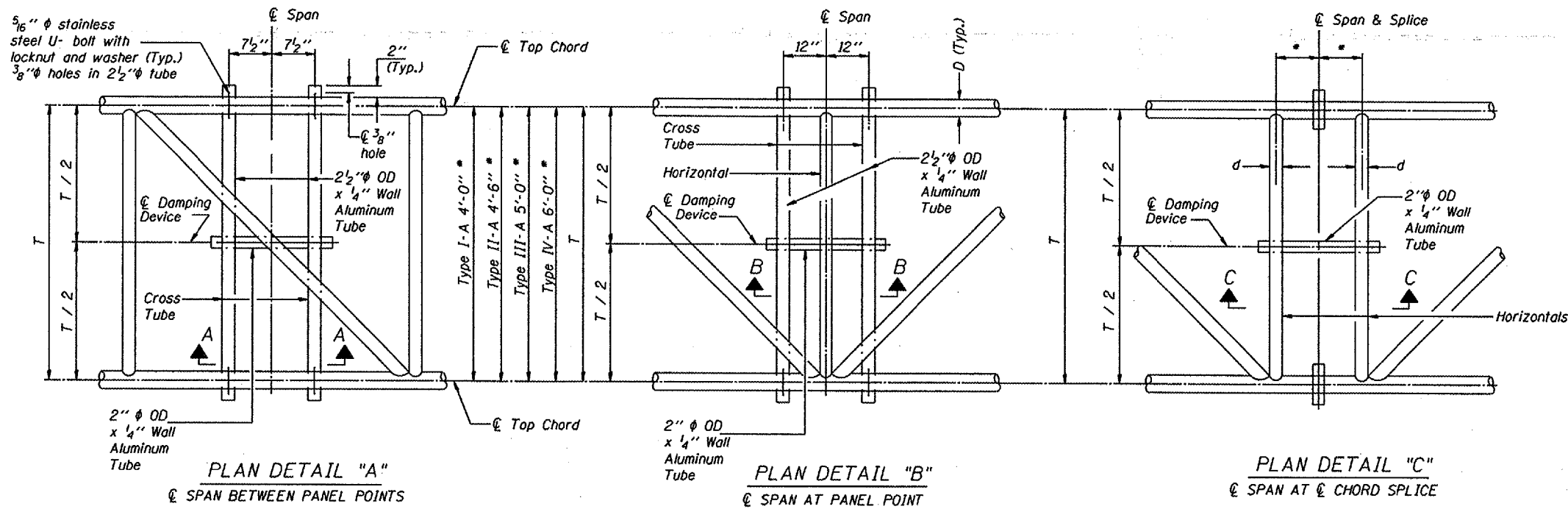

GENERAL NOTES

- Damper:** One damper per truss. (31 lbs. Stockbridge-Type Aluminum)
- Materials:** Aluminum tubes shall be ASTM B221 alloy 6061 temper T6
- Fasteners:** U-bolts shall be produced from ASTM A276 Type 304, 304L, 316 or 316L, Condition A, cold finish, or an equivalent material acceptable to the Engineer. All nuts shall be stainless steel conforming to ASTM A194, Grade B (AISI Type 304) or Grade 8F (AISI Type 303). The nuts shall be "locknuts" with nylon or steel inserts and semifinished hexagonal heads equivalent to the finished hex series of the American National Standards. All washers shall be stainless steel conforming to ASTM A240, Type 302 or 304.

DESIGNED	20
CHECKED	EXAMINED
DRAWN	PASSED
CHECKED	ENGINEER OF BRIDGES AND STRUCTURES

OVERHEAD SIGN STRUCTURE DAMPING DEVICE

District 4
Overhead Sign Structure
Repair & Replacement