

STATE OF ILLINOIS
DEPARTMENT OF TRANSPORTATION

ROUTE NO.	SECTION	COUNTY	SHEET NO.	SHEET NO. 52
S. A. P.	4B-1-R	WILL	87	50
FED. ROAD DIST. NO. 7	ILLINOIS	FED. AID PROJECT		SHEETS S17

CONTRACT NO. 62269

GENERAL NOTES:

- Fasteners shall be AASHTO M164 Type 1, mechanically galvanized bolts. Bolts $\frac{3}{4}$ in ϕ , holes $\frac{13}{16}$ in ϕ , unless otherwise noted.
- Calculated weight of Structural Steel = 63,990 pounds (M270), Grade 50
8,830 pounds (M270), Grade 36)
- Anchor bolts shall be set before bolting diaphragms over supports.
- No field welding is permitted except as specified in the contract documents.
- Reinforcement bars shall conform to the requirements of ASTM A706 Grade 60 (IL modified). See Special Provisions.
- Reinforcement bars designated (E) shall be epoxy coated.
- Plan dimensions and details relative to existing plans are subject to routine variations. The Contractor shall field verify existing dimensions and details affecting new construction and make necessary approved adjustments prior to construction or ordering of materials. Such variations shall not be cause for additional compensation for a change in scope of the work, however, the Contractor will be paid for the quantity actually furnished based upon the unit price bid for the work.
- Bearing seat surfaces shall be constructed or adjusted to the designated elevations within a tolerance of $\frac{1}{8}$ in (0.01 ft.). Adjustment shall be made either by grinding the surface or by shimming the bearings.
- The Inorganic Zinc Rich Primer / Acrylic / Acrylic Paint System shall be used for shop and field painting of new structural steel except where otherwise noted. The color of the final finish coat for all interior and exterior Steel Surfaces and bottom flanges of all beams shall be light warm gray, munsell No 10Y 7/1. See Special Provision for "Cleaning and Painting new Metal Structures".
- Load carrying components designated "NTR" shall conform to the Supplemental Requirements for Notch Toughness, Zone 2.
- Backfill shall be placed behind the abutment after the superstructure has been poured and falsework removed. See Article 502.10 of the Standard Specifications.
- All construction joints shall be bonded.
- Clean and relocate existing name plate adjacent to new plate. Cost included with Name Plates.
- The Contractor is advised that the existing PPC deck beams are in a deteriorated condition with reduced load carrying capacity. It is the Contractor's responsibility to account for the condition of the beams when developing construction procedures for removal and replacement of the superstructure.
- If the Contractor's procedures for existing beam removal or placement of new beams involves placement of heavy equipment on the existing deck beams, a detailed procedure shall be submitted to the Engineer for approval. The procedure shall include calculations, sealed by an Illinois Licensed Structural Engineer, verifying the structural adequacy of the beams for proposed loads.
- Bearing pads under existing PPC deck beams at both abutments have graphited asbestos.
- Slip forming of Concrete Parapet is not allowed.

TOTAL BILL OF MATERIAL

ITEM	UNIT	SUPER.	SUB.	TOTAL
Porous Granular Embankment (Special)	Cu yd	--	66	66
Removal of Existing Superstructures No. 2	Each	1	-	1
Concrete Removal	Cu yd	-	5	5
Structure Excavation	Cu yd	-	66	66
Floor Drains	Each	12	-	12
Concrete Structures	Cu yd	-	19.3	19.3
Concrete Superstructure	Cu yd	149	-	149
Bridge Deck Grooving	Sq yd	472	-	472
Protective Coat	Sq yd	564	-	564
Erecting Structural Steel	L Sum	0.48	-	0.48
Stud Shear Connectors	Each	3114	-	3114
Reinforcement Bars, Epoxy Coated	Pound	41070	3900	44970
Bar Splicers	Each	-	96	96
Name Plates	Each	1	-	1
Preformed Joint Strip Seal	Foot	87	-	87
Erecting Elastomeric Bearing Assembly, Type I	Each	18	-	18
Anchor Bolts, 1"	Each	24	-	24
Anchor Bolts, 1 1/4"	Each	24	-	24
Epoxy Crack Injection	Foot	-	30	30
Geocomposite Wall Drain	Sq yd	-	40	40
Pipe Underdrains for Structures, 4"	Foot	-	150	150
Structural Repair of Concrete (Depth Greater Than 5")	Sq ft	-	104	104
Structural Repair of Concrete (Depth Less Than or Equal to 5")	Sq ft	-	129	129
Asbestos Bearing Pad removal	Each	56	-	56

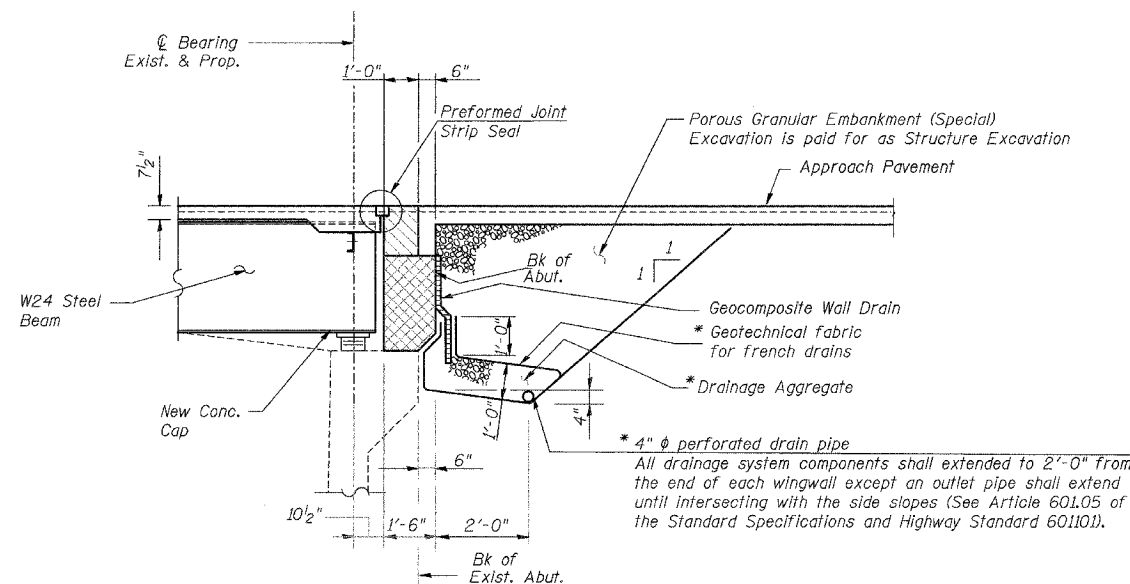

SECTION THRU ABUTMENT

(Section thru Abutment Extension Similar)

* Included in the cost of Pipe Under Drains for Structures, 4".

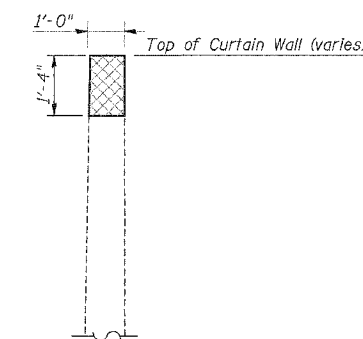

SECTION THRU CURTAIN WALL

- Area of Backwall to be constructed after removal of formwork for Superstructure
- Area of Abutment and Curtain Wall to be constructed before placement of Superstructure

DESIGNED	NDS/GMK
CHECKED	MTP/SMK/GBC
DRAWN	NDS/GMK
CHECKED	SMK/GBC

ILLINOIS DEPARTMENT OF TRANSPORTATION

GENERAL NOTES, TOTAL BILL OF MATERIAL & SECTION THRU ABUTMENT

FAP 846
SB IL. ROUTE 53 OVER PRAIRIE CREEK STATION 1305+00 SECTION 4B-1-R
WILL COUNTY
STRUCTURE NO. 099-0242
SCALE: NONE
DATE: AUGUST 2007

DELTA ENGINEERING INC.
CONSULTING ENGINEERS, CHICAGO, ILLINOIS