

DROP BOX NO. 1

LT STA. 130 + 00 (BROOKVILLE ROAD)

CONTRACT NO. 64237			
F.A.S. RTE.	SECTION	COUNTY	TOTAL SHEETS
2079	**	CARROLL & OGLE	232
STA.		TO STA.	
FED. ROAD DIST. NO.		ILLINOIS FED. AID PROJECT	
(US 52)		**(16,17,18)RS-3 & (16BR)M-1	

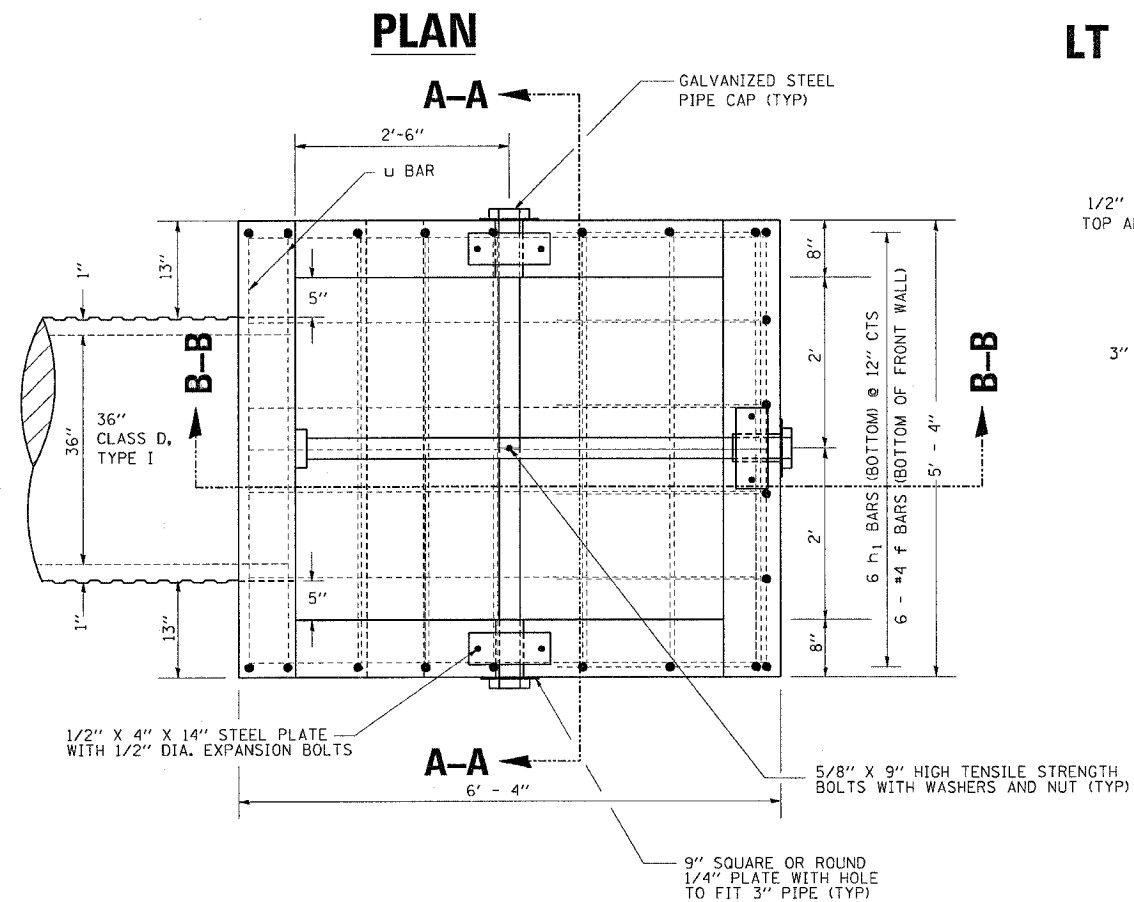

SECTION B-B

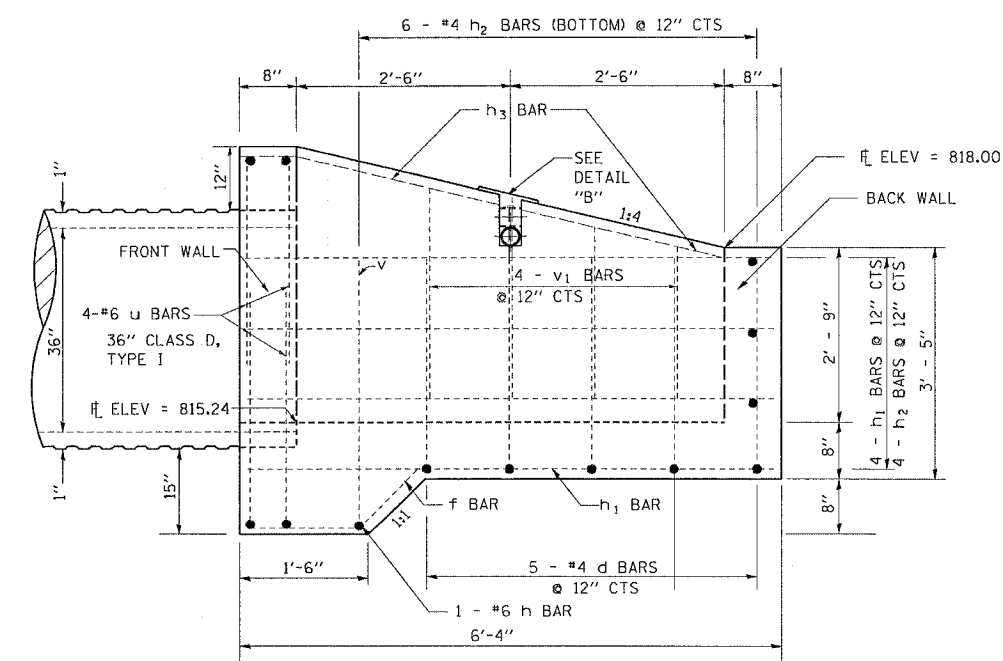

SECTION A-A

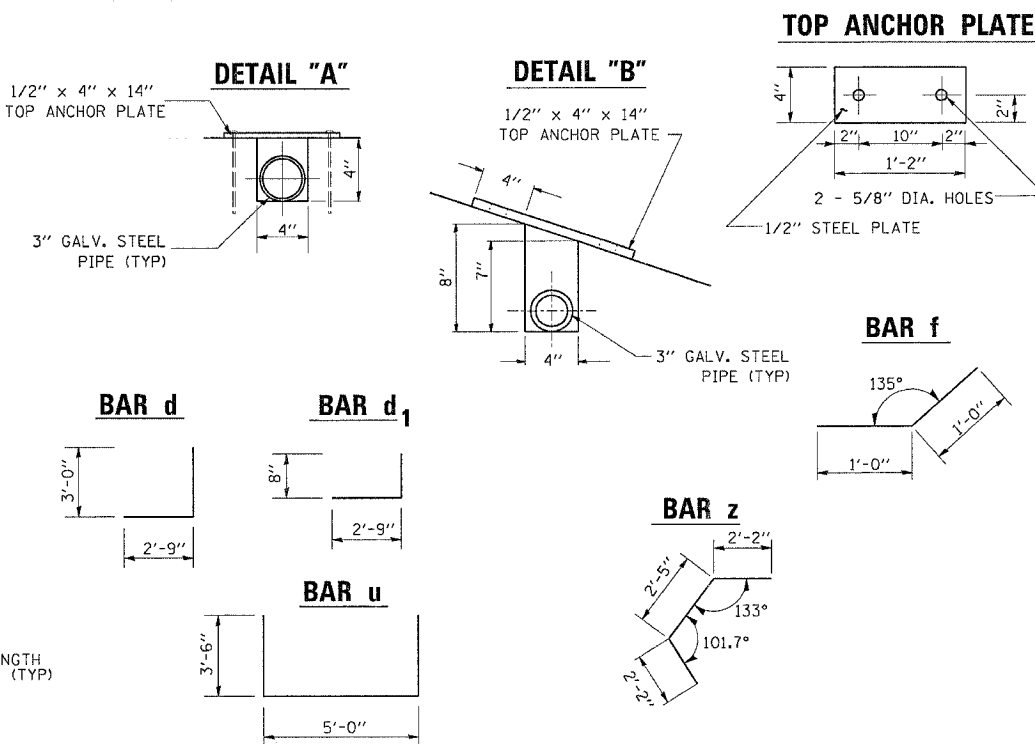
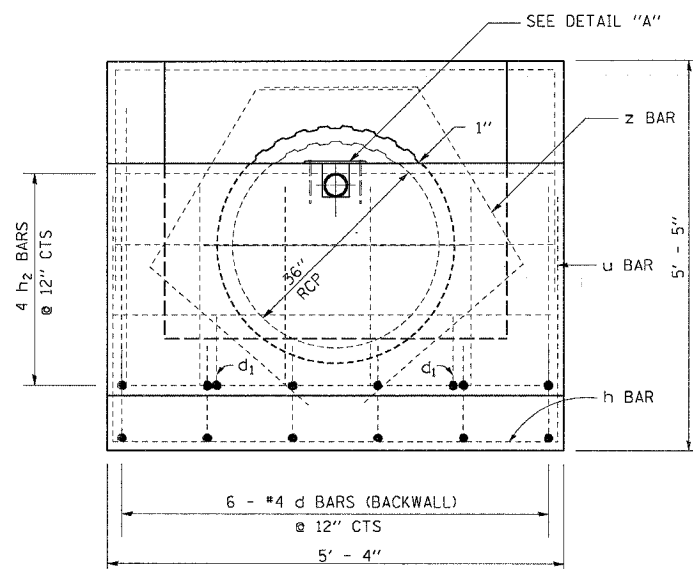

BILL OF MATERIALS (FOR REINFORCEMENT)

BAR	SIZE	NO.	LENGTH	WEIGHT (LB)
d	#4	16	5'-9"	61.46
d ₁	#4	2	3'-5"	4.56
f	#4	6	2'-0"	8.02
h	#6	1	5'-0"	7.51
h ₁	#4	12	6'-0"	48.10
h ₂	#4	8	5'-0"	26.72
u	#6	4	12'-0"	72.10
v	#4	2	3'-0"	4.01
v ₁	#4	8	2'-6"	13.36
z	#4	2	6'-9"	9.02
DESCRIPTION				
			UNIT	QTY
CLASS "SI" CONCRETE			CU YD	2.25
REINFORCEMENT BARS			LB	262.48

BILL OF MATERIALS (FOR GRATED DROP BOX No. 1)

DESCRIPTION	UNIT	QTY.
3" GALVANIZED STEEL PIPE	FOOT	1 @ 5'-4"
	FOOT	1 @ 5'-8"
3" GALV PIPE CAPS	EACH	3
1/4" GALV. STEEL PLATE (9" NOMINAL)	EACH	3
1/2" x 4" x 14" GALV. STEEL PLATE	EACH	3
5/8" x 9" GALV. STEEL BOLTS	EACH	1
EXPANSION BOLTS 1/2"Ø	EACH	6

GENERAL NOTES:

THIS WORK SHALL BE PAID FOR AT THE CONTRACT UNIT PRICE PER EACH FOR DROP BOX NO. 1.

SLOPE FLOW LINE FOR DROP BOX NO. 1 IS THE SAME RATE AS THE FLOW LINE OF THE PIPE.

BOLTS, NUTS, AND WASHERS SHALL BE IN ACCORDANCE WITH ARTICLE 1006.08 OF THE STANDARD SPECIFICATION AND SHALL BE GALVANIZED.

STEEL PIPES SHALL CONFORM TO A.S.T.M. A-53 (TYPE E OR S) GRADE B, SCHEDULE 40, AND SHALL BE GALVANIZED CONFORMING TO A.S.T.M. A-120. CONTRACTOR SHALL FIELD VERIFY PIPE LENGTH.

STEEL PLATES SHALL CONFORM TO AASHTO M-183 AND SHALL BE GALVANIZED CONFORMING TO AASHTO M-111.

REINFORCEMENT BARS SHALL CONFORM TO THE REQUIREMENTS OF AASHTO M 31 OR M 322, GRADE 40 OR 60.

SEE PLAN AND PROFILE SHEET FOR MORE INFORMATION. SEE CROSS SECTION SHEET FOR MORE INFORMATION.

PLOT DATE = Wed Mar 07 13:51:26 2007
 FILE NAME = c:\projects\13020685\13020685.dwg
 USER NAME = drcs