

CONTRACT NO.			
F.A. RTE.	SECTION	COUNTY	TOTAL SHEETS
			62
SHEET NO.		50	
STA.		TO STA.	
FED. ROAD DIST. NO.	ILLINOIS	FED. AID PROJECT	

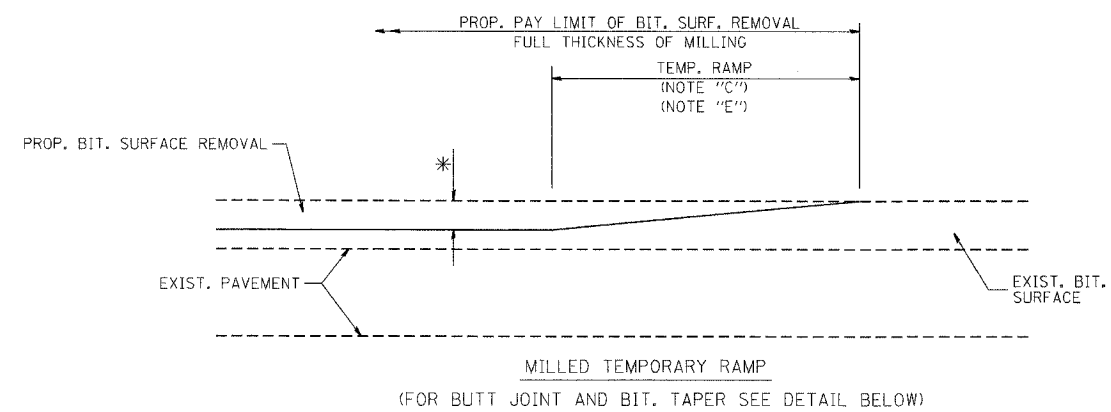

**OPTION 1**

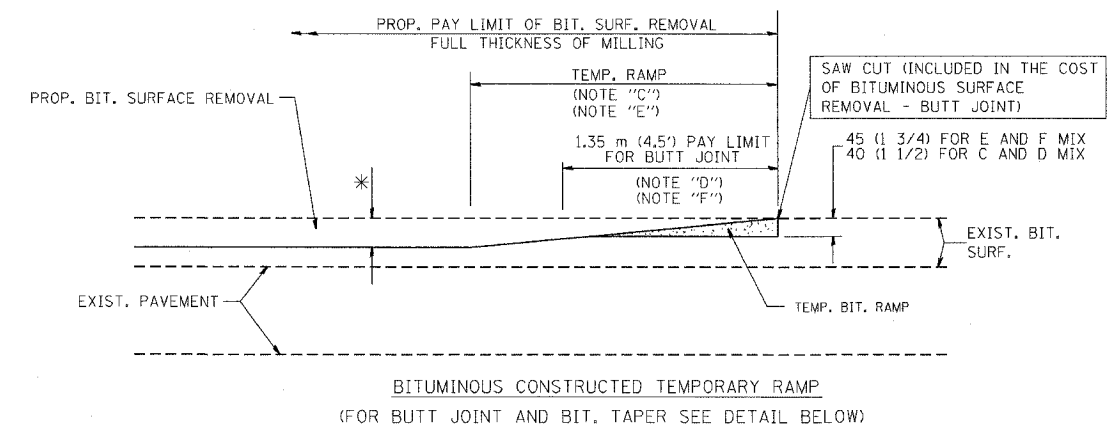

**OPTION 2  
TYPICAL TEMPORARY RAMP**

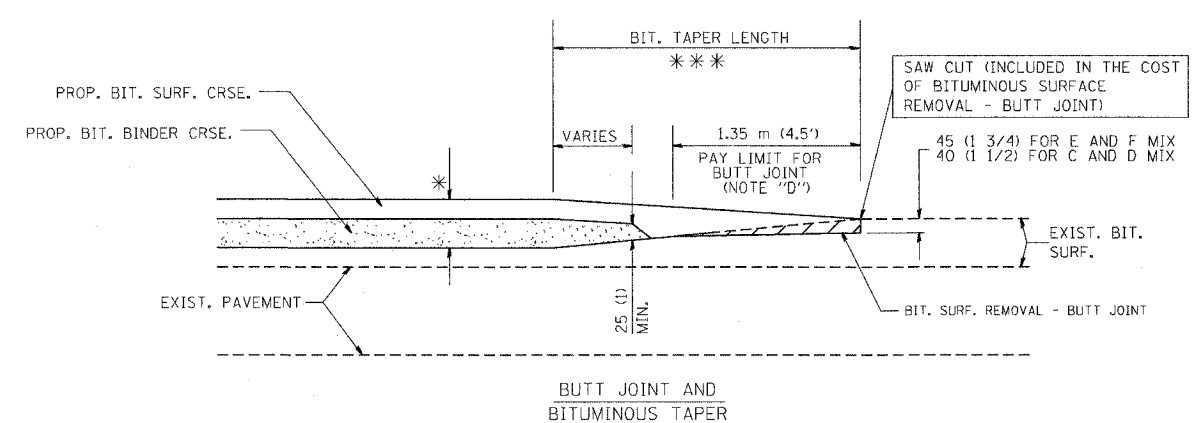

**TYPICAL BUTT JOINT AND BITUMINOUS TAPER  
FOR MILLING AND RESURFACING**

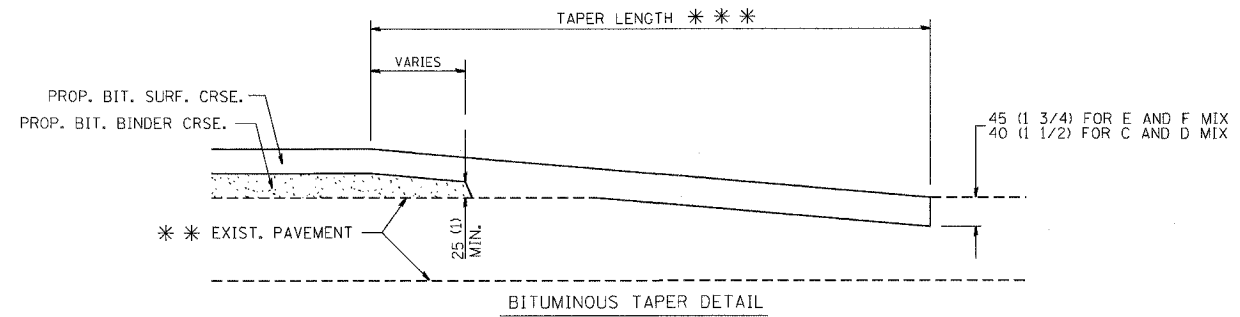
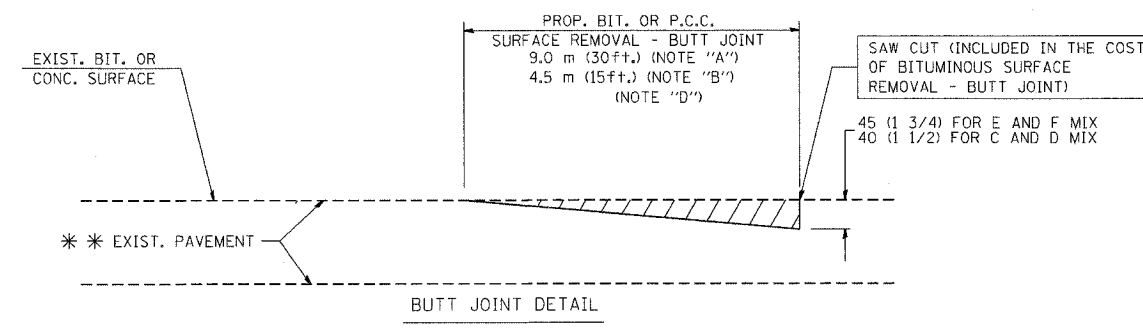

**TYPICAL BUTT JOINT AND BITUMINOUS TAPER  
FOR RESURFACING ONLY**

\*\*\* PC CONCRETE, BITUMINOUS OR BITUMINOUS RESURFACED PAVEMENT.

**NOTES**

- A: MAINLINE ROADWAYS AND MAJOR SIDE ROADS.
  - B: MINOR SIDE ROADS.
  - C: THE TEMP. RAMP SHALL BE CONSTRUCTED IMMEDIATELY UPON REMOVAL OF THE EXISTING BITUMINOUS SURFACE.
  - D: THE BUTT JOINT SHALL BE CONSTRUCTED IMMEDIATELY PRIOR TO PLACING THE PROPOSED BITUMINOUS COURSES.
  - E: TAPER THE TEMP. RAMP AT A RATE OF 900 (3 ft.) PER INCH OF MILLING THICKNESS.
  - F: INSTALLATION AND REMOVAL OF THE 1.35 m (4.5') TEMP. BIT. RAMP WILL BE PAID AS "BITUMINOUS SURFACE REMOVAL - BUTT JOINT".
  - G: SEE ARTICLE 406.18 AND 406.24 OF THE STANDARD SPECIFICATIONS FOR "BITUMINOUS AND PCC SURFACE REMOVAL, BUTT JOINT".
- \* SEE TYPICAL SECTIONS FOR MILLING THICKNESS.
- \*\*\* 6.1 m (20') PER 25 (1) RESURFACING (NOTE "A")  
3.0 m (10') PER 25 (1) RESURFACING (NOTE "B")

ALL DIMENSIONS ARE IN MILLIMETERS (INCHES) UNLESS OTHERWISE SHOWN.

**BASIS OF PAYMENT:**

THE BUTT JOINT WILL BE PAID FOR PER SQUARE METER (SQUARE YARD.) AS "BITUMINOUS SURFACE REMOVAL - BUTT JOINT" OR AS "PORTLAND CEMENT CONCRETE SURFACE REMOVAL - BUTT JOINT".

REVISIONS	
NAME	DATE
M. DE YONG	6-13-90
M. DE YONG	7-3-90
M. DE YONG	3-27-92
R. SHAH	09/09/94
R. SHAH	10/25/94
A. ABBAS	03/21/97
M. GOMEZ	04/06/01

ILLINOIS DEPARTMENT OF TRANSPORTATION

**BUTT JOINT AND BITUMINOUS TAPER DETAILS**

SCALE: VERT. HORIZ. DATE: 2/15/2006

DRAWN BY CHECKED BY

BD400-05 (VI-BD32) REVISION DATE: 04/06/01

PLOT DATE = 2/15/2006  
FILE NAME = M:\data\bd400\bd02.dgn  
PLOT SCALE = 400/1000 / IN.  
USER NAME = gregjames