

STATE OF ILLINOIS
DEPARTMENT OF TRANSPORTATION

ROUTE NO. F.A.I. 39	SECTION 50-4B	COUNTY LASALLE	SHEETS 313	SHEET 243	SHEET NO. 243
FED. ROAD DIST. NO. 7		ILL. PROJ. NO.	FED. AID PROJECT-		

Contract # 66586

NOTES:

- The quantities shown are for estimating purposes only. The area to be repaired will be determined by the Engineer at the time of construction. Actual repair locations shall be shown on the as-built plans.
- See Sheet 245 for rehabilitation of concrete pedestals.

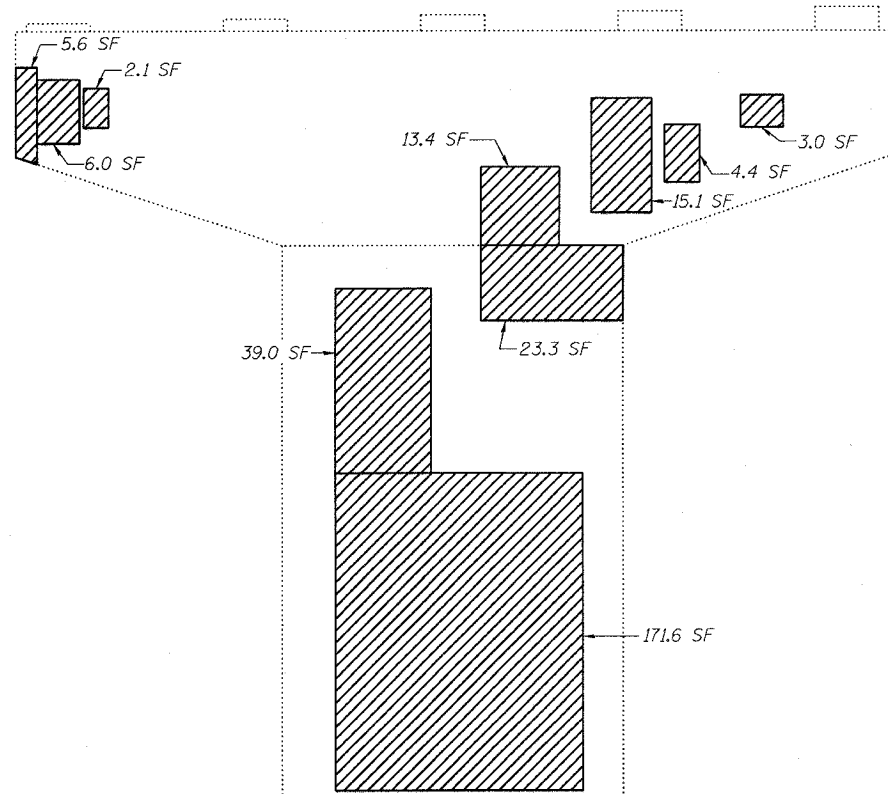
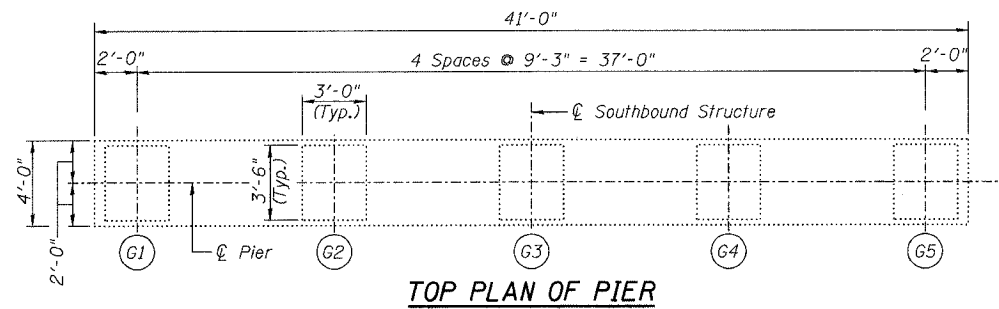

Existing Ground Line (Typ.)

ELEVATION
(Looking North)

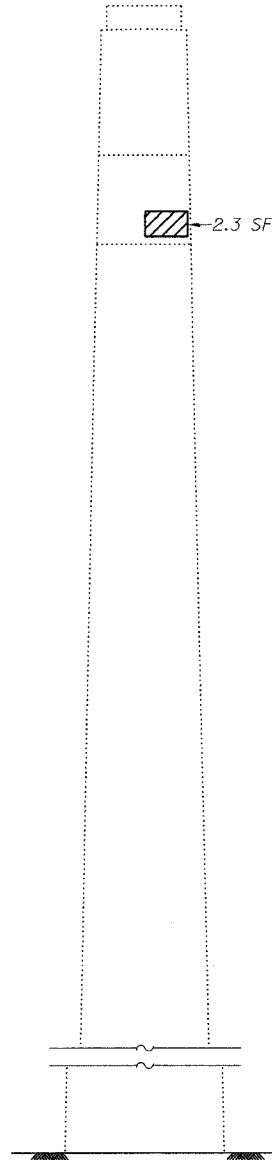

END VIEW
(Looking West)

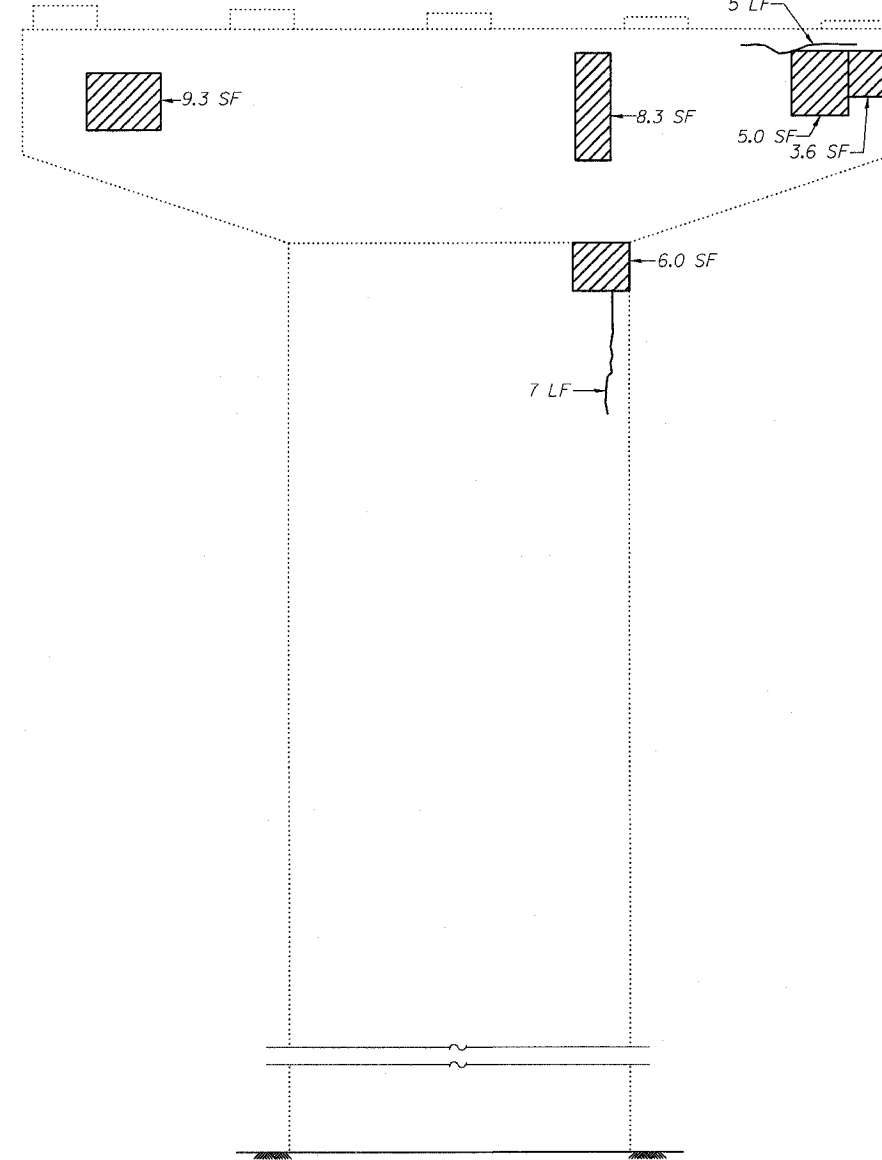

ELEVATION
(Looking South)

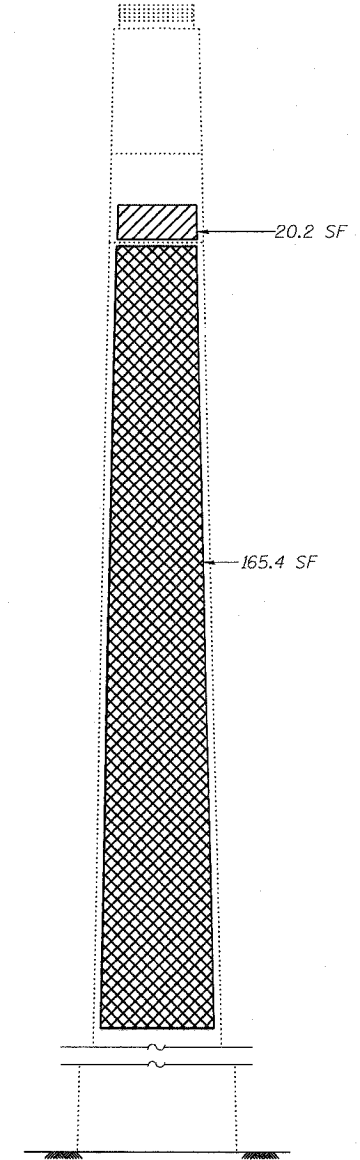

END VIEW
(Looking East)

LEGEND

- Structural Repair of Concrete (Depth equal to or less than 5")
- Structural Repair of Concrete (Depth greater than 5")
- Epoxy Crack Sealing (Cracks ≥ 1/16" Wide)
- SF Square Feet
- LF Linear Feet

BILL OF MATERIAL

ITEM	UNIT	QUANTITY
Structural Repair of Concrete (Depth equal to or less than 5")	SF	338.2
Structural Repair of Concrete (Depth greater than 5")	SF	165.4
Epoxy Crack Sealing	LF	12

DESIGNED	ADB
CHECKED	DLS
DRAWN	KHH
CHECKED	MTH

LIN ENGINEERING, LTD.
210 W. Chestnut
Chattanooga, Illinois 62629
(217) 483-4168
FAX (217) 483-4106

benesch
alfred benesch & company
Engineers • Surveyors • Planners
205 North Michigan Avenue, Suite 2400
Chicago, Illinois 60601
312-565-0450
Job # 3856

PIER REPAIR - PIER 10 SB
ABRAHAM LINCOLN MEMORIAL BRIDGE OVER
THE ILLINOIS RIVER (PUBLIC WATERS)
F.A.I. ROUTE 39 SEC. (50-4B) BR
LASALLE COUNTY
STATION 863+16.00
STRUCTURE NO. 050-0191 (SB & NB)

x:\3800s\3856\structures\dbe lincoln memorial\final\plans\From_Lin\Pier Repair\P10_SB.sht

10:06:03 AM

8/30/2006