

F.P. R.T.E.	SECTION	COUNTY	TOTAL SHEETS	SHEET NO.
63	(1-ZB-1)I-5	ADAMS	9	5
STA.		TO STA.		
FED. ROAD DIST. NO.		ILLINOIS FED. AID PROJECT		

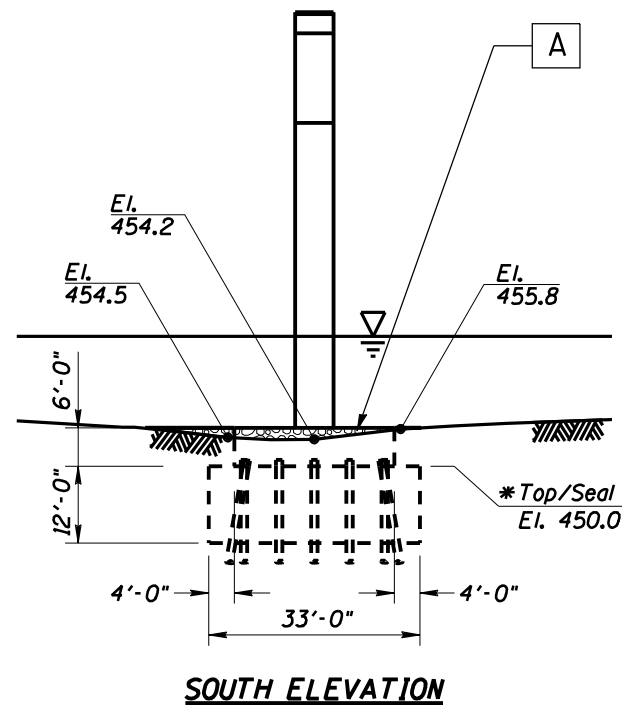

MATERIAL TO BE USED: PIER 7  
**A** STONE DUMPED RIPRAP, CLASS A6 107 TONS

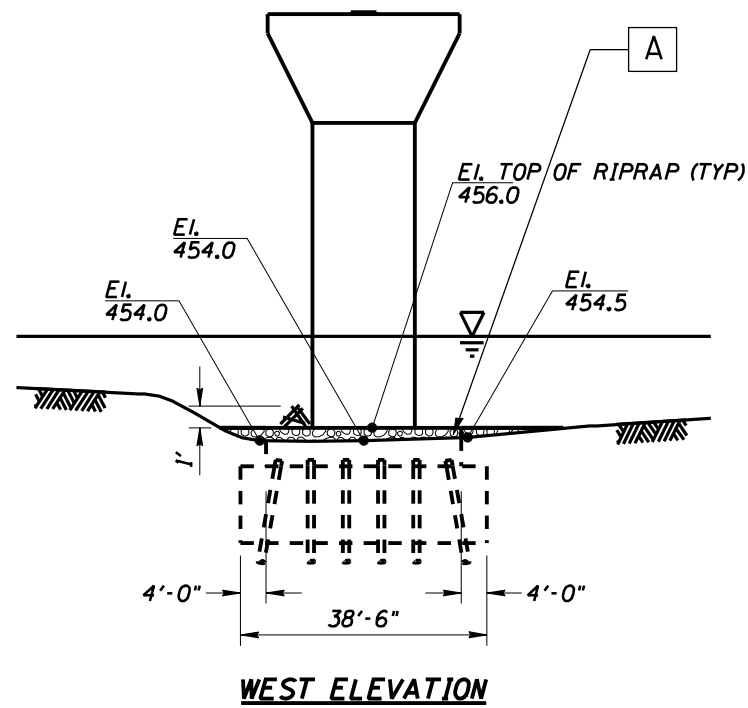
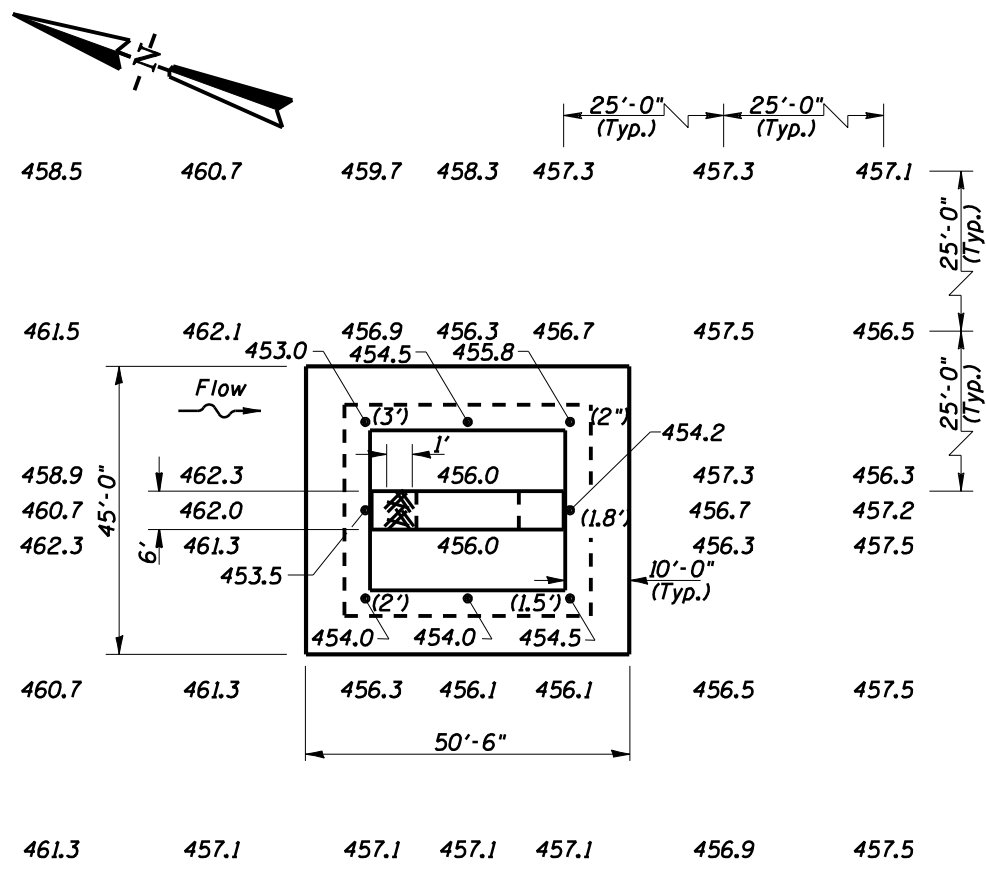
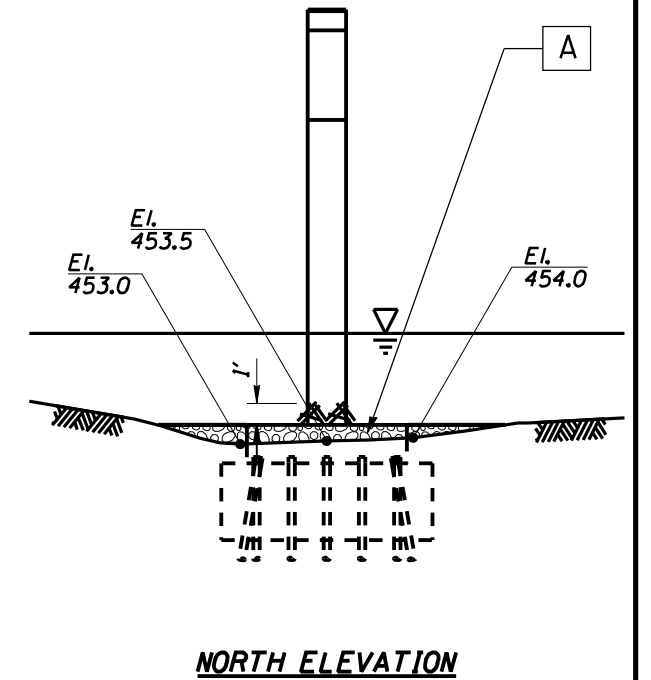
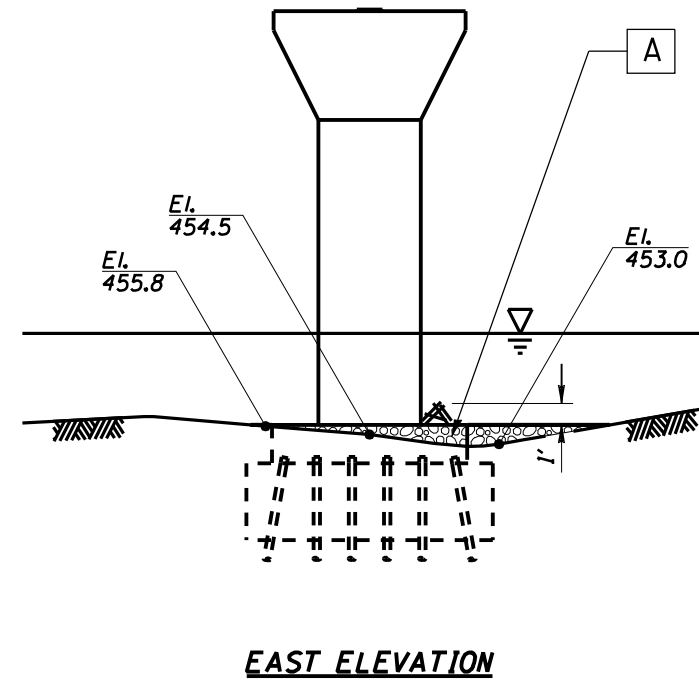

- LEGEND:
- 460.0 Channel Bottom Elevation
  - Channel Bottom Material
  - (2") Vertical Exposure on Footing Face

**ILLINOIS  
DEPARTMENT OF TRANSPORTATION**

U.S. 24 OVER  
MISSISSIPPI RIVER  
STRUCTURE NUMBER: 001-0068  
SECTION (1-ZB-1)I-5  
ADAMS COUNTY

**PIER 7**