

**ELEVATION - WEST ABUTMENT**  
(Looking West)

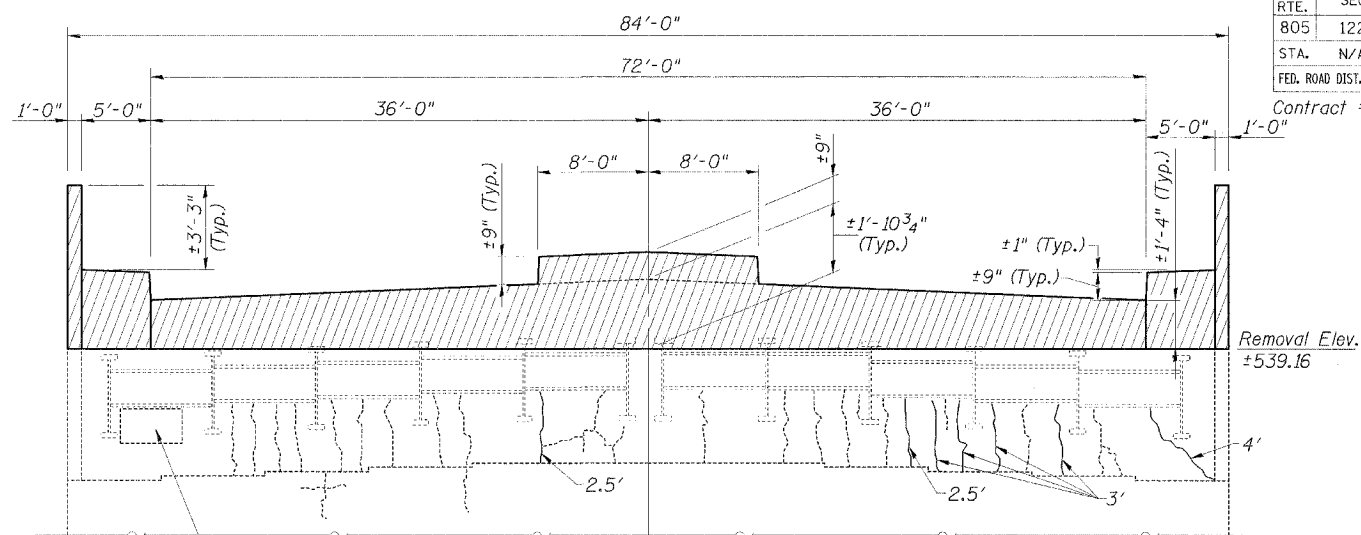

**ELEVATION - EAST ABUTMENT**  
(Looking East)

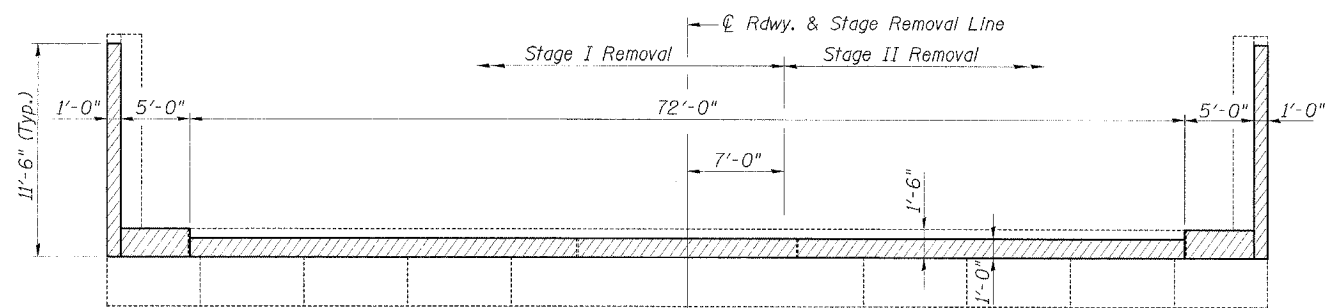

**TOP PLAN - WEST ABUTMENT**

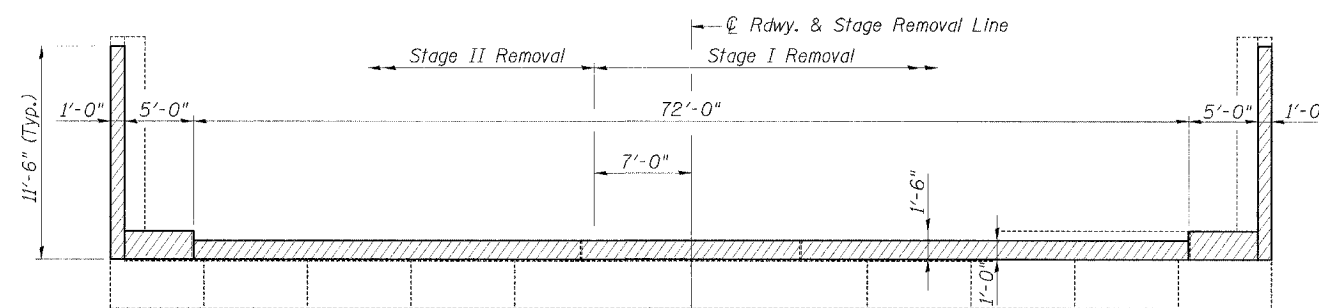

**TOP PLAN - EAST ABUTMENT**

**LEGEND**

- Concrete Removal
- Structural Repair of Concrete (Depth Equal to or Less Than 5 In.)
- Epoxy Crack Sealing (Crack widths shown are approx. 1/8" to 1/4" in width)
- Hairline Crack (Not to be sealed)

**BILL OF MATERIAL - TWO ABUTMENTS**

Item	Unit	Quantity
Concrete Removal	Cu. Yd.	20.3
Structural Repair of Concrete (Depth Equal to or Less Than 5 In.)	Sq. Ft.	2.3
Epoxy Crack Sealing	Foot	50

**NOTES**

- Existing vertical reinforcing steel to be incorporated into new work shall be cleaned, straightened, cut (if required) and incorporated into new construction. Damaged reinforcing steel shall be replaced or repaired as directed by the engineer. Cost included with "Concrete Removal".

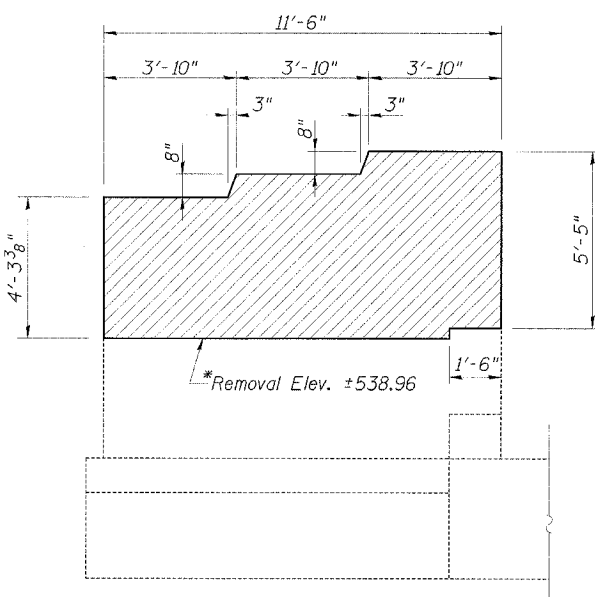

**WINGWALL ELEVATION**

\*Sawcut through the entire wall to the required elevation. Jack hammers will not be allowed. Sawcut shall be straight, level and smooth, typical requirement at all four corners.

REVISIONS	
NAME	DATE

ILLINOIS DEPARTMENT OF TRANSPORTATION  
**ABUTMENT REMOVAL & REPAIR**  
 F.A.P. ROUTE 805  
 SECTION 122VBR-1  
 ST. CLAIR COUNTY  
 ILLINOIS ROUTE 161 OVER METRO-LINK  
 STATION 69+96.56 S.N. 082-0091  
 SCALE: NONE DRAWN BY: GLD  
 DATE: 7/03/06 CHECKED BY: GBR



S:\1001\040660\10-K-Cr-Def-E-DRAW\Sheets\REVISED\DRWS STAGING CHANGE\ABUT REMOVAL REPAIR.DGN  
 7/15/2006