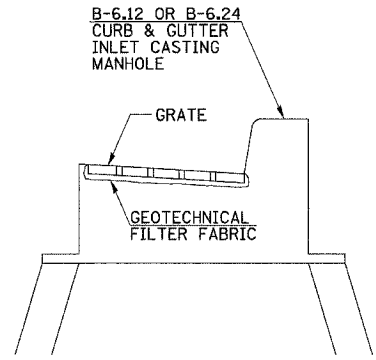
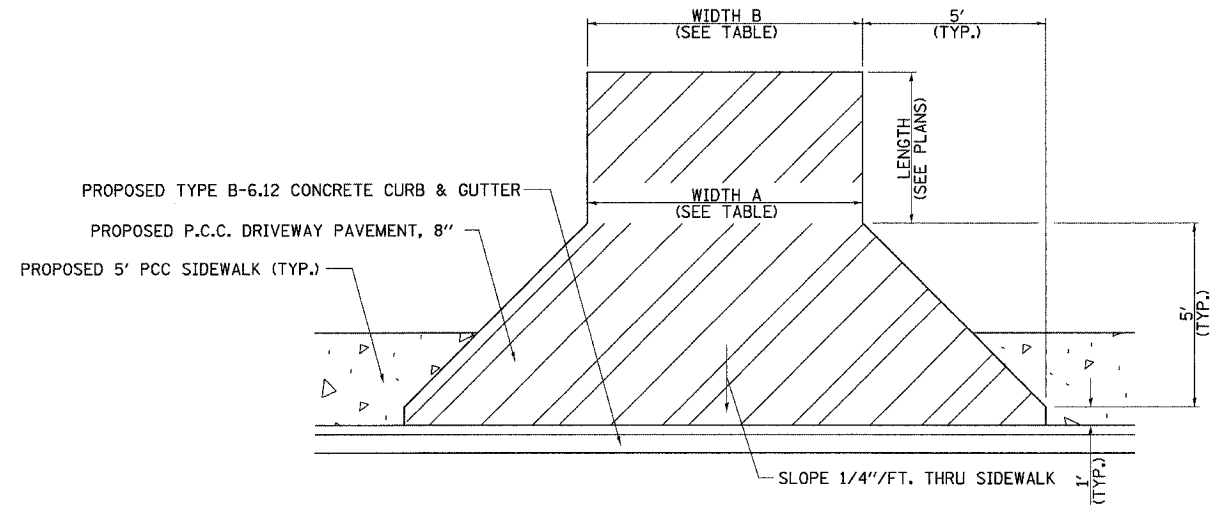

TABLE			
STATION	SIDE	WIDTH A* FT.	WIDTH B FT.
E. BROADWAY ST.			
28+65.2	RT.	12.0	12.0
SHABBONA ST.			
68+57.3	RT.	19.4	19.4
71+48.0	RT.	12.0	12.0
71+81.5	LT.	12.0	12.0
N.W. FRONTAGE ROAD			
17+67.4	LT.	15.0	15.0
18+88.6	LT.	15.0	15.0
S.W. FRONTAGE ROAD			
17+60.6	RT.	12.0	8.7
18+09.3	RT.	12.0	8.9
18+22.1	RT.	12.0	7.9
19+00.8	RT.	12.0	10.3
ILLINOIS ST.			
88+34.9	LT.	24.0	24.0
91+42.2	LT.	35.0	35.0
91+92.9	LT.	16.0	16.0

* WIDTH A IS 12.0' MIN. @ R.O.W. LINE



FILTER FABRIC-INLET PROTECTION DETAIL
 TO BE PAID FOR AT THE CONTRACT UNIT PRICE "EACH" FOR "FILTER FABRIC-INLET PROTECTION"



F.A.U. RTE. 6145 (BROADWAY ST.)

PLAN

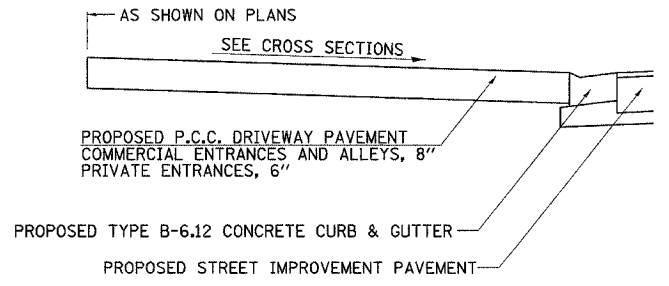

CROSS SECTION

ENTRANCE DETAILS

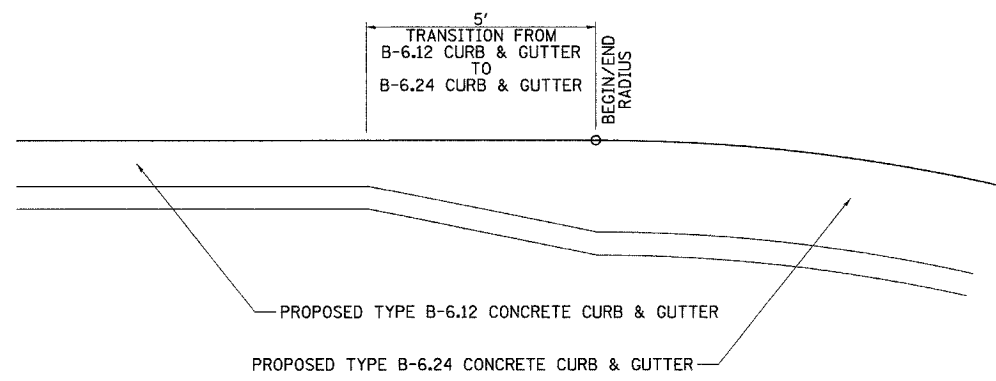

CURB & GUTTER TRANSITION DETAIL