

FIXED

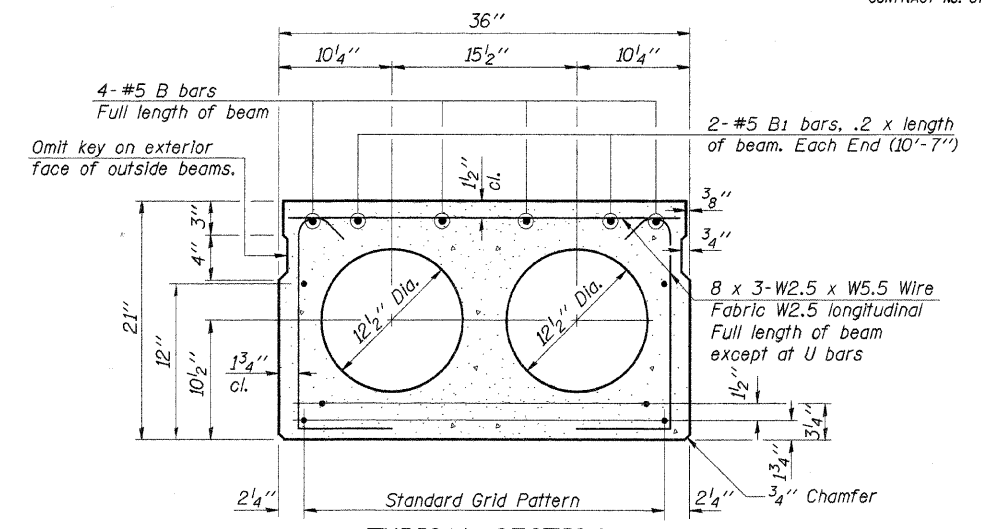

15-1/2" ϕ Strands, Each Strand Stressed to 30,900 Lbs.
7-Strands 1 3/4" up, 6-Strands 3/4" up, 2-Strands 12" up.

Note:
Place strands symmetrically about ϕ of beam.

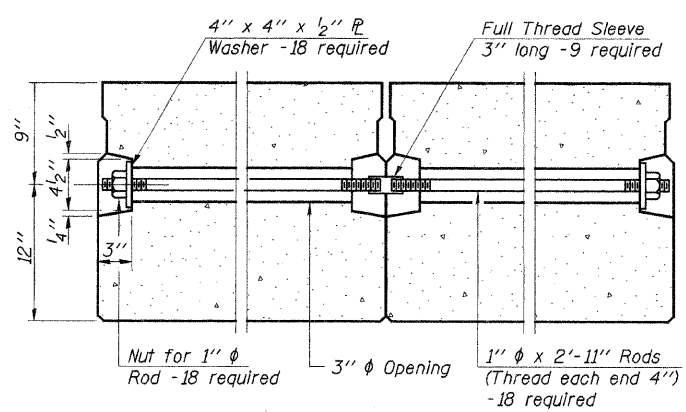
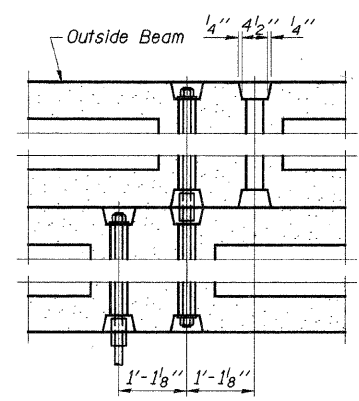
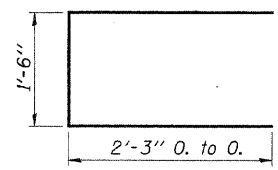
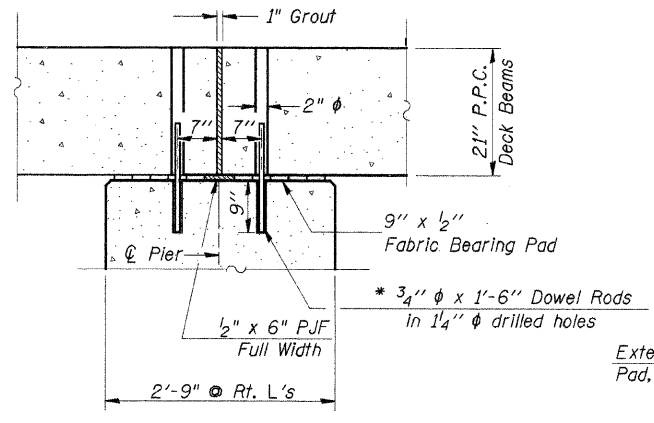
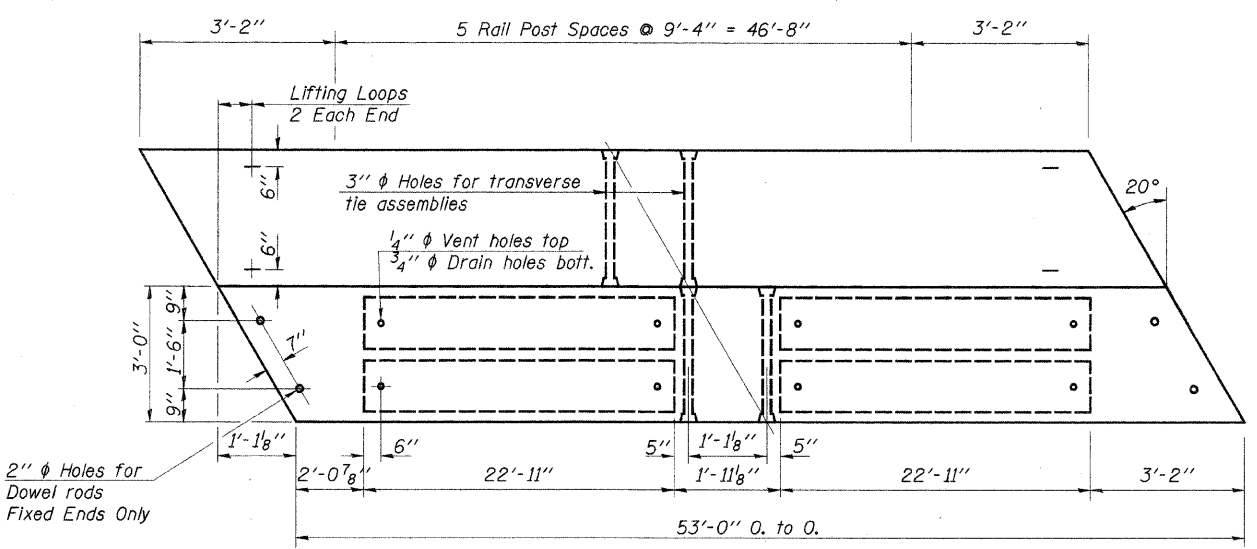

* Note: After beams are in place, 1/4" holes shall be drilled into the Substructure, and the dowel rods grouted in place and allowed to cure (Min. 24 Hrs.) prior to grouting shear key.

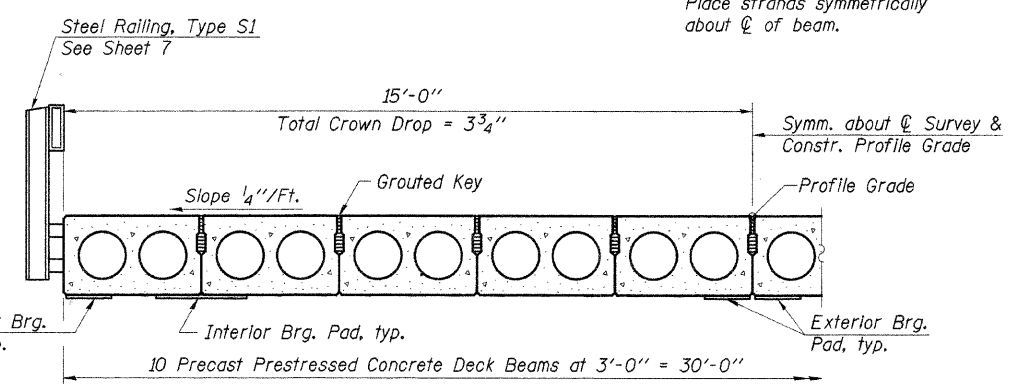

BILL OF MATERIAL

Item	Unit	Quantity
Precast Prestressed Concrete Deck Beams (21" Depth)	Sq. Ft.	1590

Estimated Total Weight (One Beam) = 31,000 Pounds

NOTES

- Prestressing steel shall be uncoated high strength, low relaxation 7-wire strand, Grade 270. The nominal diameter shall be 1/2" and the nominal cross-sectional area shall be 0.153 sq. in. Lifting loops shall be 2-1/2" ϕ 270 ksi strands, as shown.
- The 1" ϕ rods in the transverse tie assembly shall be tightened to a snug fit and the threads set. Pockets that receive transverse tie bar on outside shall be filled with grout after transverse tie assembly is in place.
- Non prestressing steel shall conform to AASHTO M-31, M-42 or M-53 Grade 60.
- The bearing seat surfaces shall be adjusted by shimming to assure firm and even bearing. Two 1/8" fabric adjusting shims of the dimensions of the Exterior Bearing Pad shall be provided for each bearing. (48 Req'd.)
- Keyway surfaces shall be cleaned to remove form oil or other bond breaking material prior to shipment of the beams. Cleaning shall be done by sandblasting the keyway areas between top of the beam and the bottom edge of the key.
- Corrosion Inhibitor, as covered in the Special Provisions, shall be used in the concrete for precast prestressed concrete deck beams.
- Required Release Strength, f'cl, shall be 4,000 p.s.i.
- See Special Provisions for review and distribution of shop drawings.
- Rail post anchor devices shall be cast into outside beam as elsewhere specified.

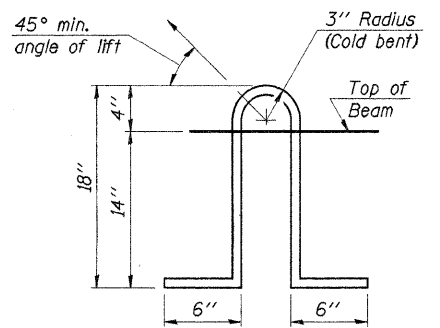
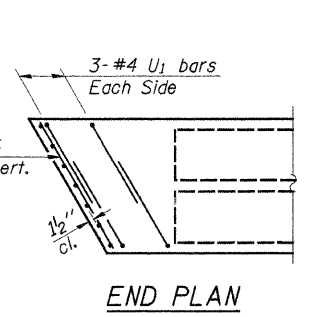

DESIGNED	S.F.M.
CHECKED	F.J.S.
DRAWN	S.A.P. & J.P.S.
CHECKED	S.F.M.

PD-3-R 9-1-03

SUPERSTRUCTURE SPAN 2

SECTION 03-00295-00-BR
VILLAGE OF CISSNA PARK
IROQUOIS COUNTY
STATION 19+11

4440 ASH GROVE SPRINGFIELD, IL 62711 (217) 793-8600 www.fehr-graham.com	FEHR-GRAHAM & ASSOCIATES, LLC ENGINEERING AND SCIENCE CONSULTANTS PREPARED BY: ROBERTO L. RODRIGUEZ, P.E. CHECKED BY: MICHELLE S. MOYER, P.E. DATE: 06/14/05	JOB NO.: 9709 FILE: SUPER.DGN DATE: 06/14/05
--	---	--