

F.A.P. RTE.	SECTION	COUNTY	TOTAL SHEETS	SHEET NO.
646	(Y)W-1, RS-3	PEORIA	142	101
STA. N/A		TO STA. N/A		
FED. ROAD DIST. NO.	ILLINOIS FED. AID PROJECT			

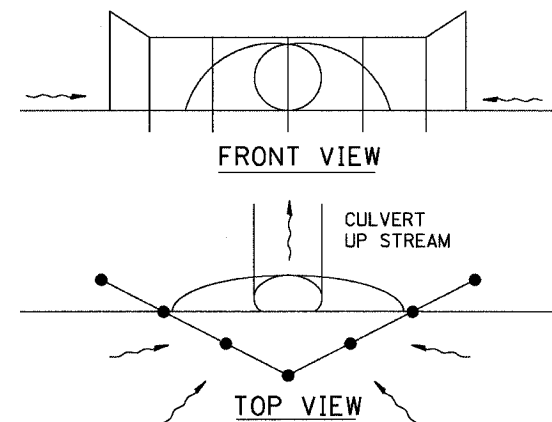

UPSTREAM PIPE CULVERT EROSION CONTROL

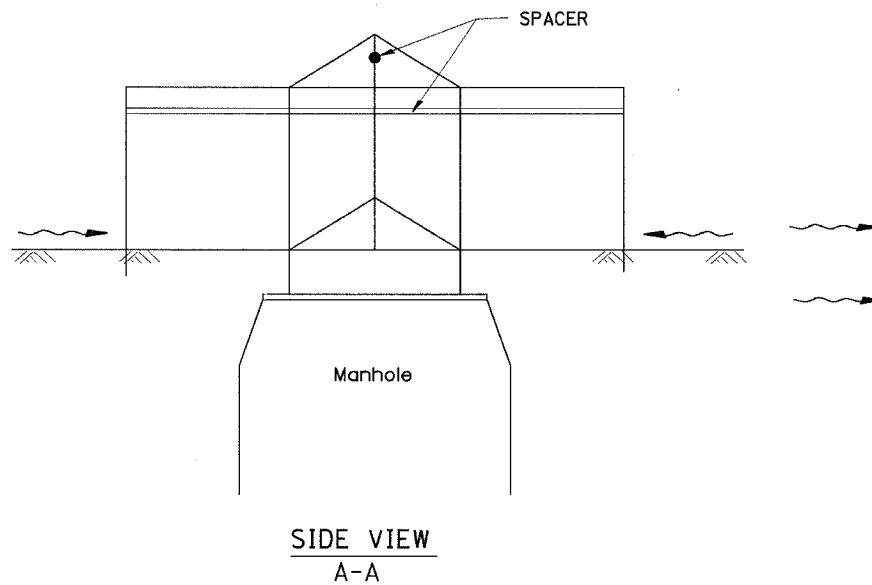

SIDE VIEW
A-A

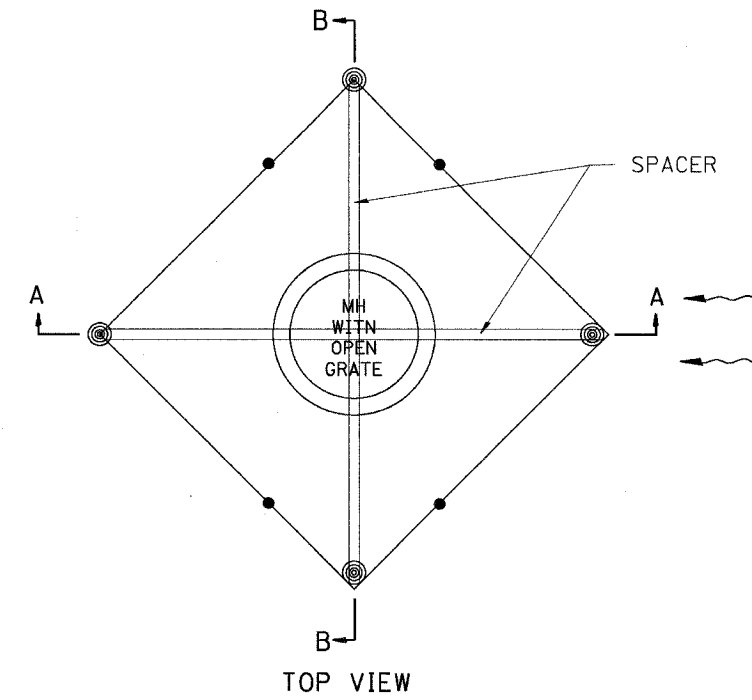

TOP VIEW

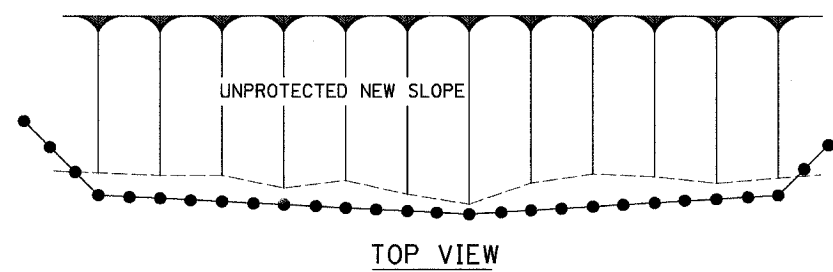

TOP VIEW

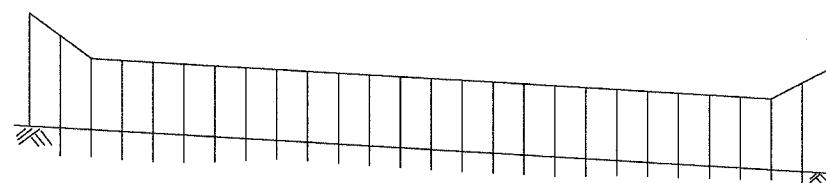

FRONT VIEW

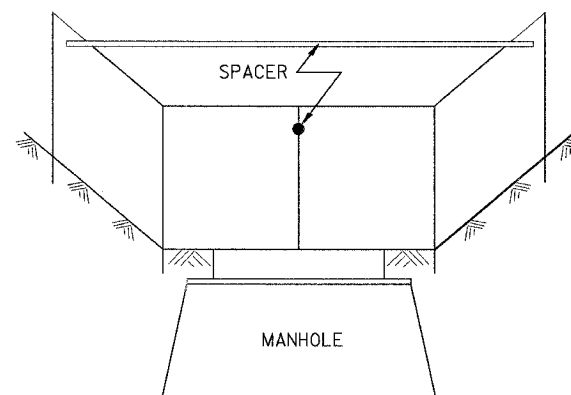

Front View
B-B

EROSION CONTROL
AT
OPEN GRATE MAN HOLE

GENERAL NOTES:

1. This work shall be performed in accordance with Sections 280 & 1081, of the Standard Specifications.
2. Additional Timber or Metal Post shall be installed, as needed.

All dimensions are in millimeters (Inches) unless otherwise noted.

ILLINOIS DEPARTMENT OF TRANSPORTATION

SPECIAL DETAIL SHEET

TYPICAL APPLICATION
OF
SILT FILTER FENCE

CADD DETAIL 280001-D4 DRAWN BY CADD
SCALE: NOT DRAWN TO SCALE CHECKED BY

DATE	REVISIONS	BY
1-1-97	RENUM. A-12.05, NEW REVISION BOX	T.P.
3-11-03	ELIMINATED SILT FENCE DITCH CHECK	M.M.A.

1. Designer to modify this Special Detail sheet, as needed, for inclusion in plans.
2. Include Highway Standard 280001 "TEMPORARY EROSION CONTROL SYSTEM."

\$\$\$DATE\$\$\$

DGN-ONLY

280001-D4