

ROUTE NO.	SECTION	COUNTY	TOTAL SHEETS	SHEET NO.
C.H. 16	06-00084	MARSHALL	15	7
F.A.S. 365	-00-BR			
ILLINOIS			FED. AID PROJ.	

CONTRACT NO. 89409

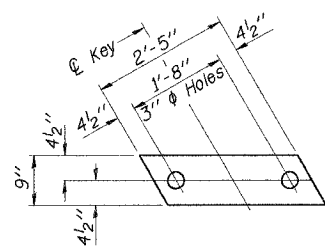

**FABRIC BEARING PAD**  
(Interior)  
(24 Req'd.)

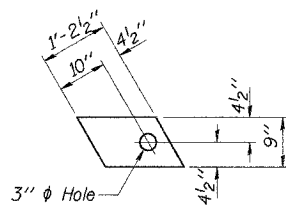

**FABRIC BEARING PAD**  
(Exterior)  
(8 Req'd.)

**FIXED**

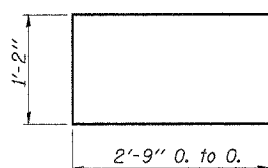

**BAR U<sub>1</sub>**

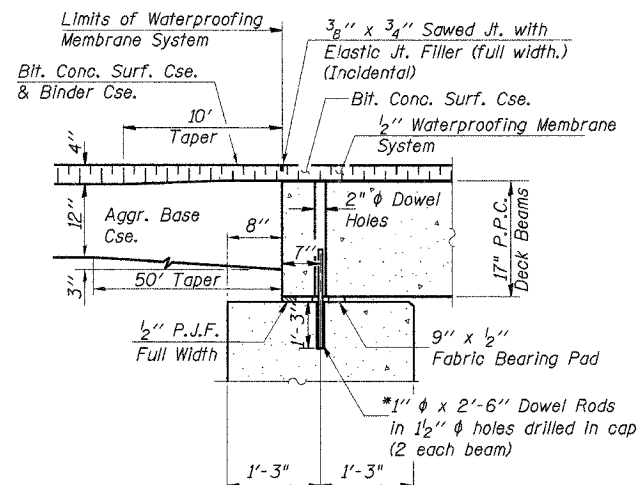

**SEC. THRU ABUT.**  
(Rt. S to Abutment)

\* Dowel Rods to be grouted after beams are in place and allowed to cure (Min. 24 hrs.) prior to grouting the shear keys.

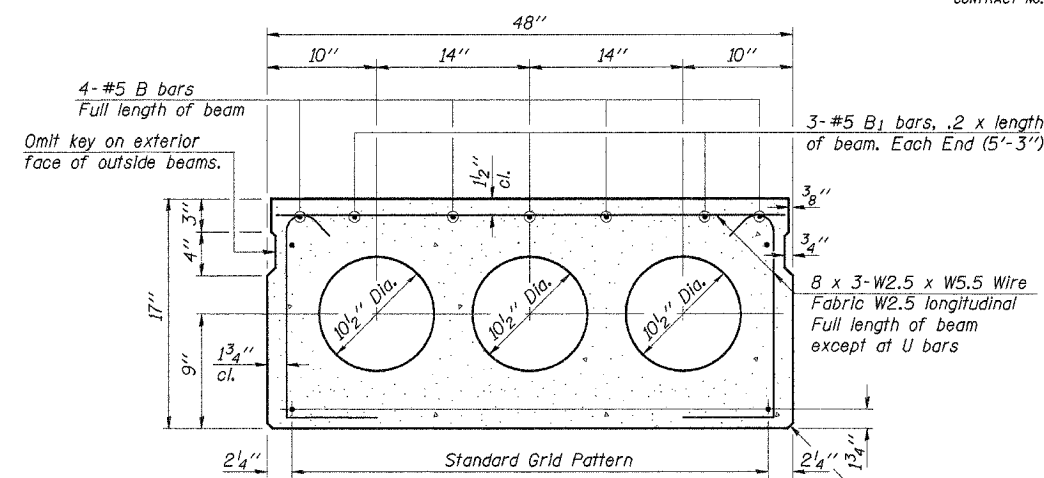

**TYPICAL SECTION**

10-1/2"  $\phi$  Strands, Each Strand Stressed to 30,900 Lbs.  
10 - Strands 1 3/4" up

Note:  
Place strands symmetrically about  $\phi$  of beam.

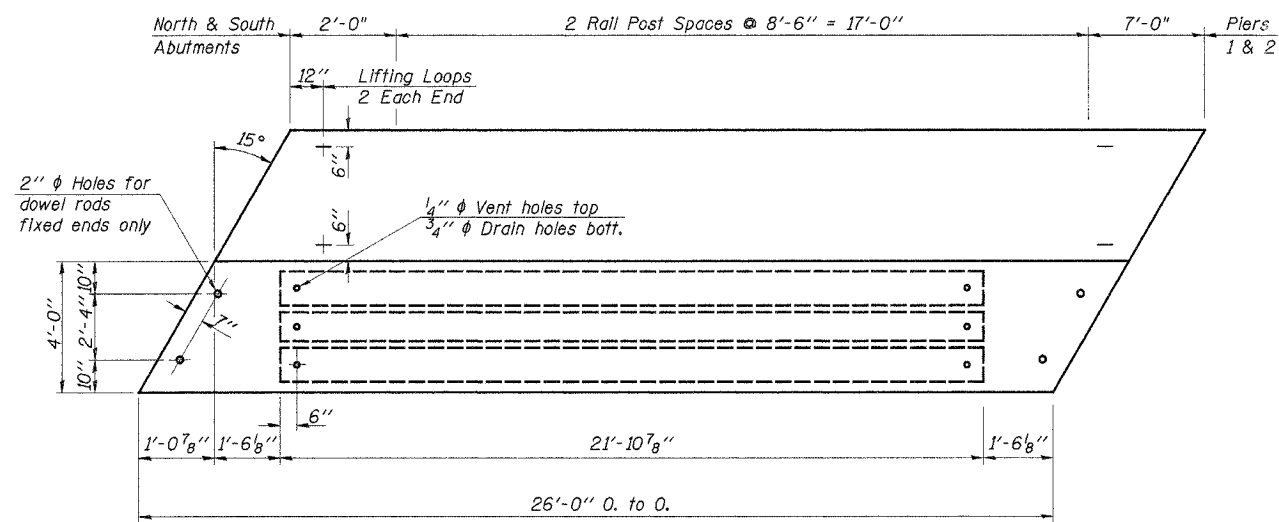

**PLAN**

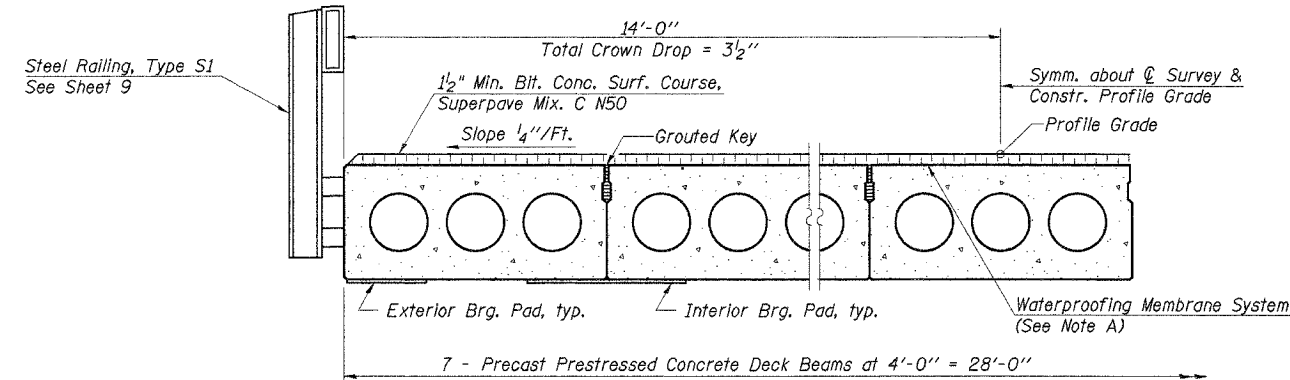

**HALF CROSS SECTION**

Note A: The top surface of the beams shall be finished in accordance with Article 504.06 of the Standard Specifications except that the surface shall not be roughed by brooming. The finished surface shall be free of depressions or high spots with sharp corners, and the top edge of keys shall be rounded or chamfered a min. of 1/4".

**BILL OF MATERIAL**

Item	Unit	Quantity
Precast Prestressed Concrete Deck Beams (17" Depth)	Sq. Ft.	1,456
Bit. Conc. Surf. Course, Superpave, Mix C, N50	Ton	19.8
Waterproofing Membrane System	Sq. Yd.	162
Portland Cement Mortar Fairing Course	Foot	156

Estimated Total Weight (One Beam) = 16,750 Pounds

**SUPERSTRUCTURE**  
**SPANS 1 & 3**  
**COUNTY HIGHWAY 16**  
**SECTION 06-00084-00-BR**  
**MARSHALL COUNTY**  
**STATION 125+55**

4440 ASH GROVE  
SPRINGFIELD, IL 62711  
(217) 793-8600  
www.fehr-graham.com

**FEHR-GRAHAM & ASSOCIATES, LLC**  
ENGINEERING AND SCIENCE CONSULTANTS  
PREPARED BY: MICHAEL S. HODGINS, P.E.  
DATE: 04/11/06

JOB NO.: 46813  
FILE: 0423SUPERL.DGN  
DATE: 04/11/06

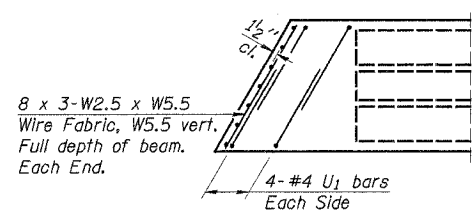

**END PLAN**

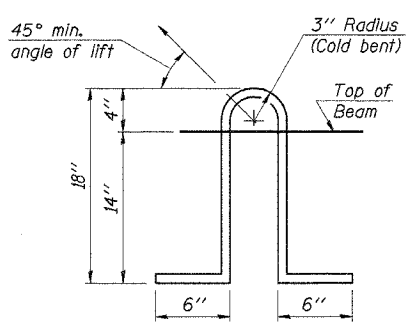

**LIFTING LOOP DETAIL**

**NOTES**

Prestressing steel shall be uncoated high strength, low relaxation 7-wire strand, Grade 270. The nominal diameter shall be 1/2" and the nominal cross-sectional area shall be 0.153 sq. in. Lifting loops shall be 2-1/2"  $\phi$ -270 ksi strands, as shown. The 1"  $\phi$  rods in the transverse tie assembly shall be tightened to a snug fit and the threads set. Pockets that receive transverse tie bar on outside shall be filled with grout after transverse tie assembly is in place. Non prestressing steel shall conform to AASHTO M-31 or M-322, Grade 60. The bearing seat surfaces shall be adjusted by shimming to assure firm and even bearing. Two 1/8" fabric adjusting shims of the dimensions of the Exterior Bearing Pad shall be provided for each bearing. (64 Req'd.) Keyway surfaces shall be cleaned to remove form oil or other bond breaking material prior to shipment of the beams. Cleaning shall be done by sandblasting the keyway areas between top of the beam and the bottom edge of the key. Required Release Strength, f'cl, shall be 4,000 p.s.i. See Special Provisions for review and distribution of shop drawings. Roll post anchor devices shall be cast into outside beam as elsewhere specified.

DESIGNED	F.J.S.
CHECKED	S.F.M.
DRAWN	S.A.P.
CHECKED	S.F.M.

PD-4-L 9-1-03