

STATE OF ILLINOIS
DEPARTMENT OF TRANSPORTATION

F.A. RTE.	SECTION	COUNTY	TOTAL SHEETS	SHEET NO.
VARIOUS	D3 H-T PVMNT MRK RPR 18-30	VARIOUS	15	1
		ILLINOIS	CONTRACT NO. 46468	

D-3

INDEX OF SHEETS

- 1. COVER SHEET
- 2 - 4. SUMMARY OF QUANTITIES
- 5 - 6. EXAMPLE WORK ORDER SHEETS
- 7. SCHEDULE
- 8 - 15. PAVEMENT MARKING DETAILS

PROPOSED HIGHWAY PLANS

VARIOUS ROUTE
SECTION D3 H-T PVMNT MRK RPR 18-30
PAVEMENT MARKING
VARIOUS COUNTIES
M-60-001-18

STANDARDS

- 701006-05 OFF-ROAD OPERATIONS 2L, 2W, 15' (4.5 m) TO 24" (600 mm) FROM PAVEMENT EDGE
- 701101-05 OFF-ROAD OPERATIONS, MULTILANE, 15' (4.5 m) TO 24" (600 mm) FROM PAVEMENT EDGE
- 701311-03 LANE CLOSURE, 2L, 2W, MOVING OPERATIONS - DAY ONLY
- 701400-09 APPROACH TO LANE CLOSURE, FREEWAY/EXPRESSWAY
- 701401-10 LANE CLOSURE, FREEWAY/EXPRESSWAY
- 701406-11 LANE CLOSURE, FREEWAY/EXPRESSWAY, DAY OPERATIONS ONLY
- 701411-09 LANE CLOSURE, MULTILANE, AT ENTRANCE OR EXIT RAMP FOR SPEEDS ≥ 45 MPH
- 701426-09 LANE CLOSURE, MULTILANE INTERMITTENT OR MOVING OPERATION, FOR SPEEDS ≥ 45 MPH
- 701427-05 LANE CLOSURE, MULTILANE INTERMITTENT OR MOVING OPERATION, FOR SPEEDS ≤ 40 MPH
- 701428-01 TRAFFIC CONTROL, SETUP AND REMOVAL, FREEWAY/EXPRESSWAY
- 701501-06 URBAN LANE CLOSURE, 2L, 2W, UNDIVIDED
- 701502-07 URBAN LANE CLOSURE 2L, 2W, WITH BIDIRECTIONAL LEFT TURN LANE
- 701601-09 URBAN LANE CLOSURE, MULTILANE, 1W OR 2W WITH NONTRAVERSABLE MEDIAN
- 701602-08 URBAN LANE CLOSURE, MULTILANE, 2W WITH BIDIRECTIONAL

701901-07 TRAFFIC CONTROL DEVICES
700001-05 TYPICAL PAVEMENT MARKINGS

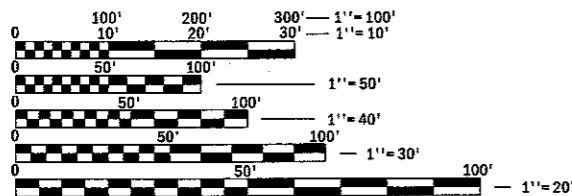
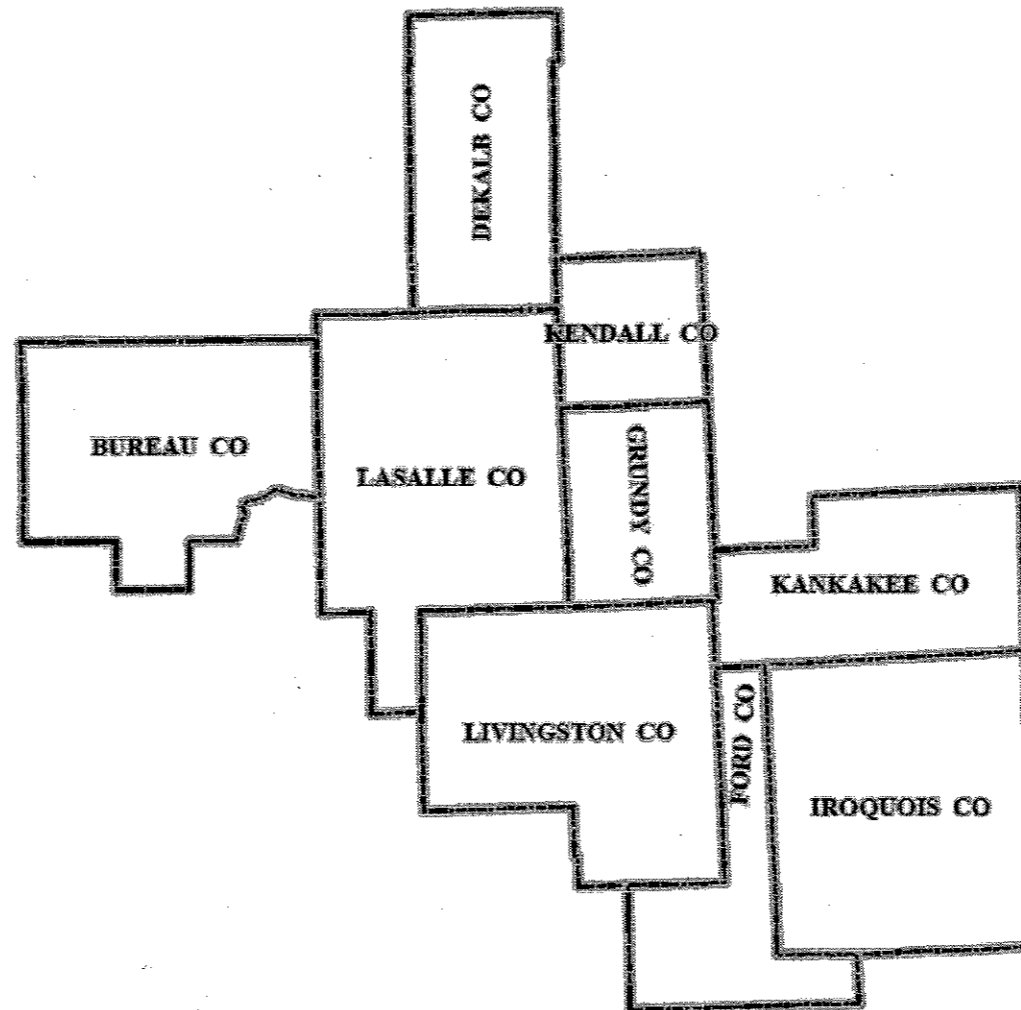
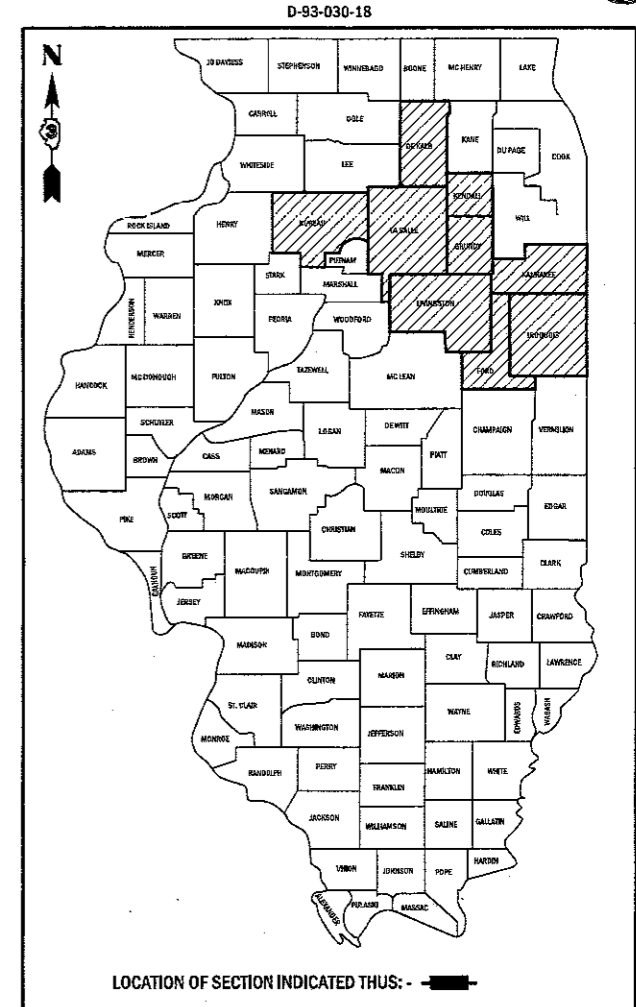

FULL SIZE PLANS HAVE BEEN PREPARED USING STANDARD ENGINEERING SCALES. REDUCED SIZED PLANS WILL NOT CONFORM TO STANDARD SCALES. IN MAKING MEASUREMENTS ON REDUCED PLANS, THE ABOVE SCALES MAY BE USED.

J.U.L.I.E.
JOINT UTILITY LOCATION INFORMATION FOR EXCAVATION
1-800-892-0123
OR 811

PROJECT ENGINEER: JOE KANNEL P.E.
UNIT CHIEF: RON WOODSHANK
DISTRICT 3 NO. (815) 434-6131
CONTRACT NO. 46468

STATE OF ILLINOIS
DEPARTMENT OF TRANSPORTATION

SUBMITTED Sept. 5 2017
Ag. Sills, RPA REGIONAL ENGINEER

Oct 13 2017
Maureen M. Addis, PE ENGINEER OF DESIGN AND ENVIRONMENT

Oct 13 2017
[Signature] DIRECTOR OF PROGRAM DEVELOPMENT 2

PRINTED BY THE AUTHORITY
OF THE STATE OF ILLINOIS

REV

RURAL

CODE NO.	ITEM	UNIT	TOTAL QUANTITY	CONSTR. CODE	
				100% STATE ✓	PAVEMENT MARKING
				0021 ✓	NONE
78000100	THERMOPLASTIC PAVEMENT MARKING - LETTERS AND SYMBOLS	SQ FT	4000		4000
78000200	THERMOPLASTIC PAVEMENT MARKING - LINE 4"	FOOT	7000		7000
78000400	THERMOPLASTIC PAVEMENT MARKING - LINE 6"	FOOT	1000		1000
78000500	THERMOPLASTIC PAVEMENT MARKING - LINE 8"	FOOT	7000		7000
78000600	THERMOPLASTIC PAVEMENT MARKING - LINE 12"	FOOT	1000		1000
78000650	THERMOPLASTIC PAVEMENT MARKING - LINE 24"	FOOT	1000		1000
78003130	PREFORMED PLASTIC PAVEMENT MARKING, TYPE B - LINE 6"	FOOT	5000		5000
X2700002	PREFORMED PLASTIC PAVEMENT MARKING, TYPE B - LINE 8"; <i>SPECIAL</i>	FOOT	9000		9000
78003180	PREFORMED PLASTIC PAVEMENT MARKING, TYPE B - LINE 24"	FOOT	1000		1000
78005110	EPOXY PAVEMENT MARKING - LINE 4"	FOOT	100000		100000
78005130	EPOXY PAVEMENT MARKING - LINE 6"	FOOT	1000		1000
78005140	EPOXY PAVEMENT MARKING - LINE 8"	FOOT	4000		4000
78008210	POLYUREA PAVEMENT MARKING TYPE I - LINE 4"	FOOT	950000		950000
78008230	POLYUREA PAVEMENT MARKING TYPE I - LINE 6"	FOOT	90000		90000

14

MODEL: Default
 FILE: \\mspc-pw\illinois\egc\illinois\pwr\pwr\DOT\Documents\DOT_Office\Bkktl_3P\050513145468\CADD\24044663-14-4663.dgn

USER NAME = woodsharkri	DESIGNED -	REVISED -
	DRAWN -	REVISED -
PLOT SCALE = 100,0000' / in.	CHECKED -	REVISED -
PLOT DATE = 8/30/2017	DATE -	REVISED -

STATE OF ILLINOIS
DEPARTMENT OF TRANSPORTATION

SUMMARY OF QUANTITIES	
SCALE:	SHEET 1 OF 3 SHEETS STA. TO STA.

F.A. RTE.	SECTION	COUNTY	TOTAL SHEETS	SHEET NO.
VARIOUS	D3 H-T PVMNT MRK RPR 18-30	VARIOUS	15	2
ILLINOIS FED. AID PROJECT			CONTRACT NO. 46463	

REV

MODEL: Default
 FILE NAME: \\ILL084CIBINTEG\Illinois\gov-PWD\DOT\Documents\ADOT_Offices\Bartlett_3\Projects\10246-6B\CD\Draw\12345678-100-cover.dwg

RURAL

CODE NO.	ITEM	UNIT	TOTAL QUANTITY	CONSTR. CODE
				100% STATE
				PAVEMENT MARKING
				0021
				NONE
78008240	POLYUREA PAVEMENT MARKING TYPE I - LINE 8"	FOOT	25000	25000
78009000	MODIFIED URETHANE PAVEMENT MARKING - LETTERS AND SYMBOLS	SQ FT	8000	8000
78009004	MODIFIED URETHANE PAVEMENT MARKING - LINE 4"	FOOT	850000	850000
78009006	MODIFIED URETHANE PAVEMENT MARKING - LINE 6"	FOOT	80000	80000
78009008	MODIFIED URETHANE PAVEMENT MARKING - LINE 8"	FOOT	60000	60000
78009012	MODIFIED URETHANE PAVEMENT MARKING - LINE 12"	FOOT	8000	8000
78009024	MODIFIED URETHANE PAVEMENT MARKING - LINE 24"	FOOT	3000	3000
X0327979	PAVEMENT MARKING REMOVAL - GRINDING	SQ FT	500	500
X0327980	PAVEMENT MARKING REMOVAL - WATER BLASTING	SQ FT	500	500
X7800815	HOT SPRAY THERMOPLASTIC PAVEMENT MARKING LINE - 4 INCH	FOOT	400000	400000
X7800835	HOT SPRAY THERMOPLASTIC PAVEMENT MARKING LINE - 6 INCH	FOOT	40000	40000
X7800845	HOT SPRAY THERMOPLASTIC PAVEMENT MARKING LINE - 8 INCH,	FOOT	7500	7500
X7830068	GROOVING FOR RECESSED PAVEMENT MARKING, LETTERS, NUMBERS AND SYMBOLS	SQ FT	4000	4000
X7830070	GROOVING FOR RECESSED PAVEMENT MARKING 5"	FOOT	100000	100000

14

USER NAME = woodshankrl	DESIGNED -	REVISED -
PLOT SCALE = 100,0000' / in.	DRAWN -	REVISED -
PLOT DATE = 8/30/2017	CHECKED -	REVISED -
	DATE -	REVISED -

**STATE OF ILLINOIS
DEPARTMENT OF TRANSPORTATION**

SUMMARY OF QUANTITIES			
SCALE:	SHEET 2	OF 3	SHEETS

F.A. RTE.	SECTION	COUNTY	TOTAL SHEETS	SHEET NO.
VARIOUS	D3 I-T PVMNT MRK RPR 18-30	VARIOUS	15	3
CONTRACT NO. 46468				
ILLINOIS FED. AID PROJECT				

REV

SCHEDULE - PREFORMED PLASTIC PAVEMENT MARKING - LINE 8''	
ALL 8 INCH PPM SHALL BE CONTRAST MARKING	
LOCATION	FOOT
ALL	9000

MODEL: Default
FILE NAME: P:\1108\B&E\BIDD\ITEC\Illinois.gov\PW\DOT\Documents\DOT_Offices\Director\3\Projects\0316168\CADD\0316168-8-8-17-cover.dwg

USER NAME = woodshankr	DESIGNED -	REVISED -
	DRAWN -	REVISED -
PLOT SCALE = 100.0000 ' / in.	CHECKED -	REVISED -
PLOT DATE = 8/30/2017	DATE -	REVISED -

**STATE OF ILLINOIS
DEPARTMENT OF TRANSPORTATION**

SCHEDULE		F.A. RTE.	SECTION	COUNTY	TOTAL SHEETS	SHEET NO.
		VARIOUS	D3 H-T PVMNT MRK RPR 18-30	VARIOUS	15	5
SCALE:	SHEET 1	OF 1	SHEETS	STA.	TO STA.	

		ILLINOIS	FED. AID PROJECT
		CONTRACT NO. 46468	

VARIOUS ROUTES
D3 H-T PVMT MRK RPR 18-30
VARIOUS COUNTIES
CONTRACT NO. 46468

WORK ORDER
D3 H-T PVMT MRK RPR 18-30

WORK ORDER NO. _____ DATE OF ISSUE: _____ ROUTE: _____

LOCATION DESCRIPTION: _____

CONTRACT NO: 46468 JOB NO: M-60-001-18

CODE NUMBER	ITEM	UNIT	QUANTITY	UNIT PRICE	ITEM COST
78000100	THPL PVT MK LTR & SYM	SQ FT			
78000200	THPL PVT MK LINE 4	FOOT			
78000400	THPL PVT MK LINE 6	FOOT			
78000500	THPL PVT MK LINE 8	FOOT			
78000600	THPL PVT MK LINE 12	FOOT			
78000650	THPL PVT MK LINE 24	FOOT			
78003130	PREF PL PM TB 6	FOOT			
78003140	PREF PL PM TB 8	FOOT			
78003180	PREF PL PM TB 24	FOOT			
78005110	EPOXY PVT MK LINE 4	FOOT			
78005130	EPOXY PVT MK LINE 6	FOOT			
78005140	EPOXY PVT MK LINE 8	FOOT			
78008210	POLYUREA PM T1 LN 4	FOOT			
78008230	POLYUREA PM T1 LN 6	FOOT			
78008240	POLYUREA PM T1 LN 8	FOOT			
78009000	MOD URETH PM - LTR & SYM	SQ FT			
78009004	MOD URETH PM LINE 4	FOOT			
78009006	MOD URETH PM LINE 6	FOOT			
78009008	MOD URETH PM LINE 8	FOOT			
78009012	MOD URETH PM LINE 12	FOOT			
78009024	MOD URETH PM LINE 24	FOOT			
X0327979	PAVMT MRKG REM GRIND	SQ FT			
X0327980	PAVMT MRKG WTR BL	SQ FT			
X7800815	HS THPL PM LN 4	FOOT			
X7800835	HS THPL PM LN 6	FOOT			
X7800845	HS THPL PM LN 8	FOOT			
X7830068	GRV RCSD PVT LTR-SYM	SQ FT			
X7830070	GRV RCSD PVT MRKG 5	FOOT			
X7830074	GRV RCSD PVT MRKG 7	FOOT			
X7830076	GRV RCSD PVT MRKG 9	FOOT			
X7830078	GRV RCSD PVT MRKG 13	FOOT			
X7830090	GRV RCSD PVT MRKG 25	FOOT			
Z0008758	AERIAL SPEED CHK MK	FOOT			

DISTRICT CONTACT
NAME: _____
TELEPHONE NO: _____
CELL PHONE NO: _____

SUBMITTED BY: _____
Regional Engineer
DATE: _____
APPROVED BY: _____
Traffic Engineer of Operations
DATE: _____

MODEL: Default
FILE: \\mhc-pw\illinois\dot\Documents\DOT_Offices\DI\erict_3\projects\0346468\CADD\0346468-01-01-01.dwg

USER NAME = woodshankr	DESIGNED -	REVISED -	STATE OF ILLINOIS DEPARTMENT OF TRANSPORTATION	EXAMPLE WORK ORDER SHEETS			F.A. RTE.	SECTION	COUNTY	TOTAL SHEETS	SHEET NO.
	DRAWN -	REVISED -					VARIOUS	D3 H-T PVMT MRK RPR 18-30	VARIOUS	15	6
PLOT SCALE = 100,0000' / in.	CHECKED -	REVISED -		SCALE: _____ SHEET 1 OF 2 SHEETS STA. _____ TO STA. _____			CONTRACT NO. 46468				
PLOT DATE = 8/30/2017	DATE -	REVISED -					ILLINOIS FED. AID PROJECT				

PAVEMENT MARKING SUMMARY

LOCATION ROUTE (LOCAL DESCRIPTION) COUNTY	Summation of Quantities: 46468 (M-60-001-18)								Work Order #		
	Letters & Symbols	4" Foot	4" Foot	6" Foot	8" Special Foot	12" Foot	12" Foot	24" Foot	Pavement Grooving L&S Sq Ft	Pavement Grooving Foot	Aerial Speed Chk Mk Foot
	Sq Ft	(White)	(Yellow)			(White)	(Yellow)				

MODEL: Default
FILE: \\nas01c.pva.uiuc.edu\BID\NITEC\Illinois\gov\PIV\DOT\Documents\DOT_Offices\Director\3\Projects\0316168\CAD\0316168-Chk-cov.ecd.dgn

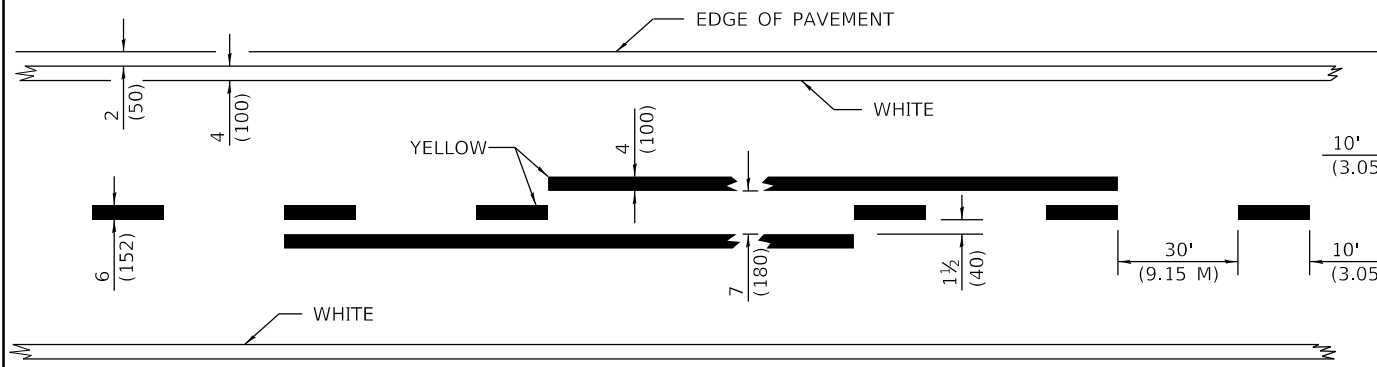

2 LANE

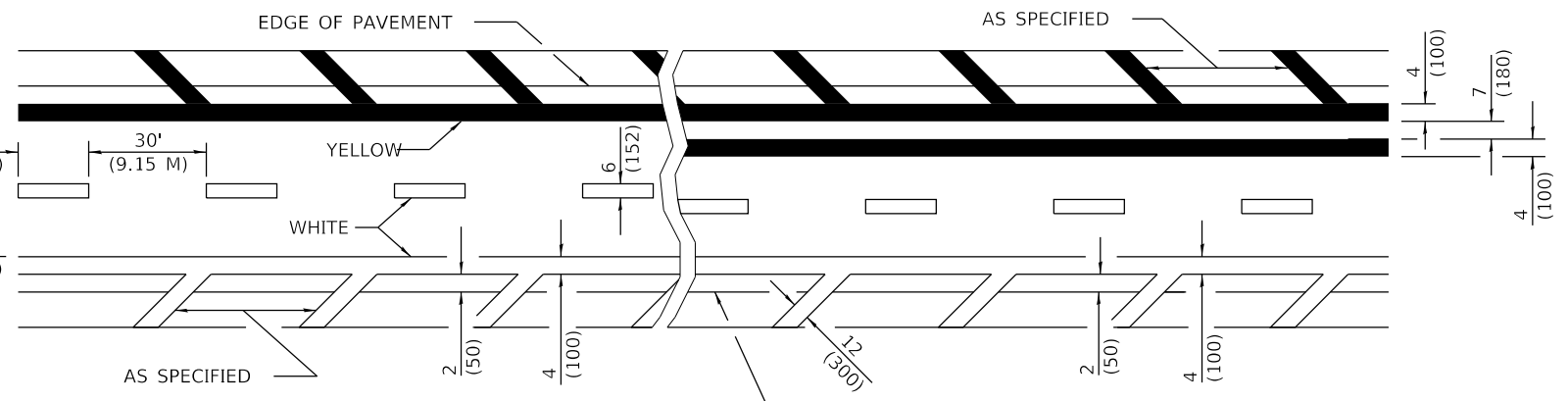

MULTI LANE

LANE AND EDGE LINES

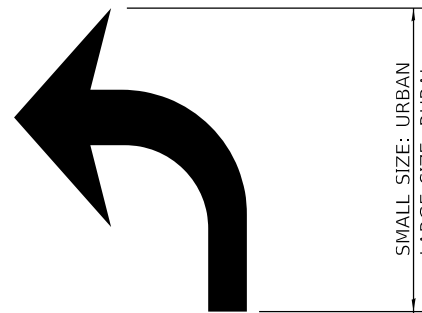

20' (6 M): URBAN
50' (15 M): RURAL
(BETWEEN ARROW AND WORD OR BETWEEN WORDS)



WORD AND ARROW LAYOUT

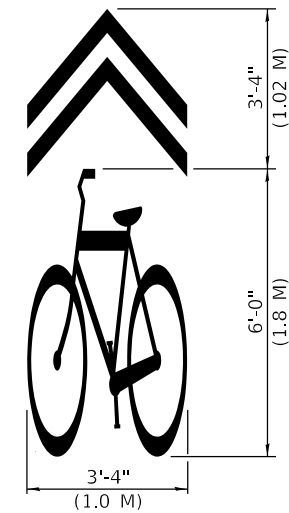

SHARED LANE SYMBOL

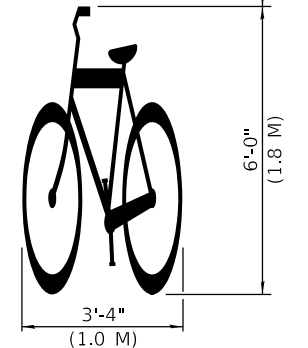
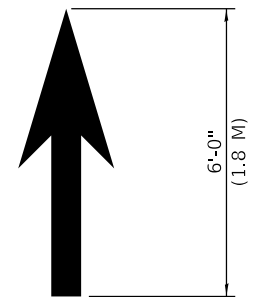

BIKE SYMBOL (ARROW IS OPTIONAL.)

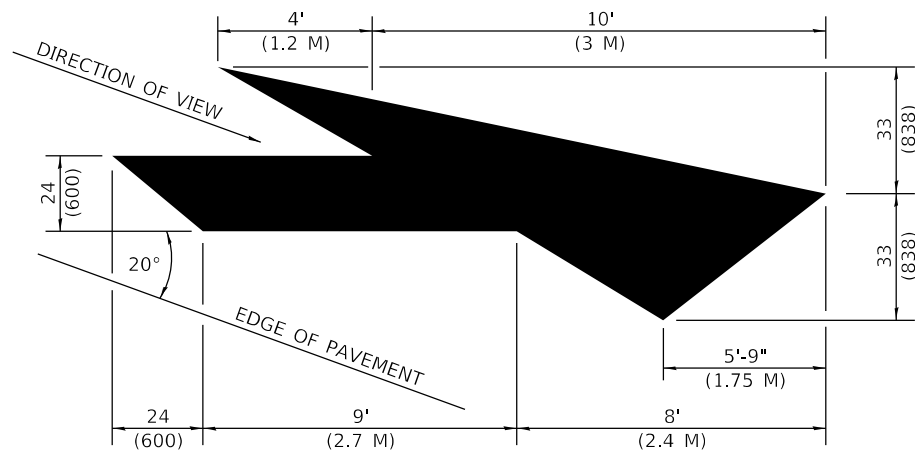

LANE-REDUCTION ARROW

RIGHT LANE-REDUCTION ARROW SHOWN.
USE MIRROR IMAGE FOR LEFT LANE.

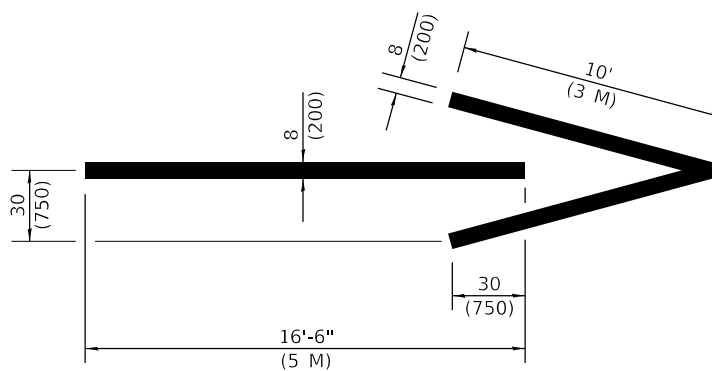

WRONG WAY ARROW

MODEL: Default
FILE: A:\misc\pav\ILLINOIS\DOT\Documents\11DOT OFFICES\11D01\031668\CADD\DATA\031668-24-68-2b-cover.dgn

USER NAME = woodshankr	DESIGNED -	REVISED -
	DRAWN -	REVISED -
PLOT SCALE = 100.0000' / in.	CHECKED -	REVISED -
PLOT DATE = 8/30/2017	DATE -	REVISED -

STATE OF ILLINOIS
DEPARTMENT OF TRANSPORTATION

PAVEMENT MARKING DETAILS

SCALE: SHEET 1 OF 8 SHEETS STA. TO STA.

F.A. RTE.	SECTION	COUNTY	TOTAL SHEETS	SHEET NO.
VARIOUS	D3 H-T PVMNT MRK RPR 18-30	VARIOUS	15	8
CONTRACT NO. 46468				

ILLINOIS FED. AID PROJECT

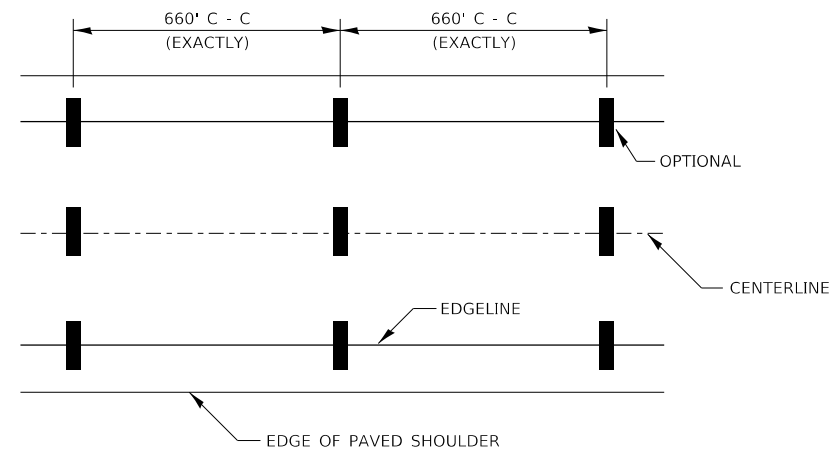

IT WILL BE NECESSARY TO HAVE A REPRESENTATIVE OF THE STATE POLICE PRESENT SO THAT THE ACCURACY OF MEASUREMENT CAN BE ATTESTED TO IN COURT.

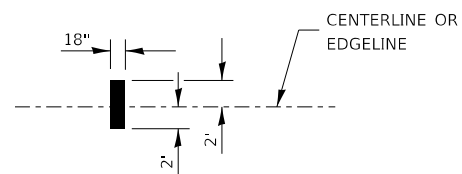

AERIAL SPEED CHECK ZONES

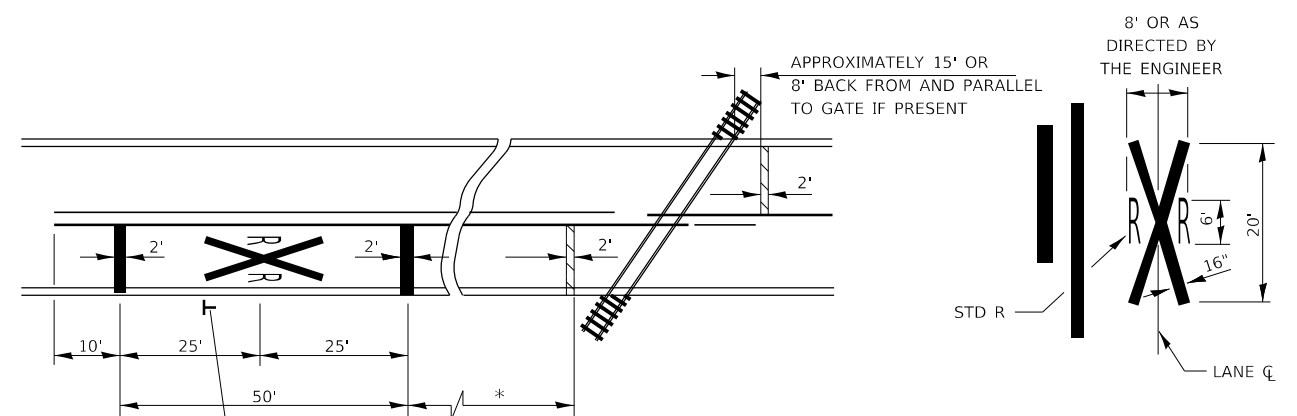

* MINIMUM DISTANCE
 500' FOR 55 MPH
 375' FOR 45 MPH
 250' FOR 35 MPH OR LESS

NOTES:
 THE TRANSVERSE SPREAD OF THE "X"
 MAY VARY ACCORDING TO LANE WIDTH.

ON MULTI-LANE ROADS, THE STOP LINES
 SHALL EXTEND ACROSS ALL APPROACH
 LANES AND SEPARATE RXR SYMBOLS SHALL
 BE PLACED ADJACENT TO EACH OTHER
 IN EACH LANE.

WHEN THE PAVEMENT MARKING SYMBOL
 IS USED, A PORTION OF THE SYMBOL
 SHOULD BE LOCATED DIRECTLY ADJACENT
 TO THE ADVANCE WARNING SIGN (W10-1).

PAVEMENT MARKINGS AT RAILROAD-HIGHWAY GRADE CROSSING

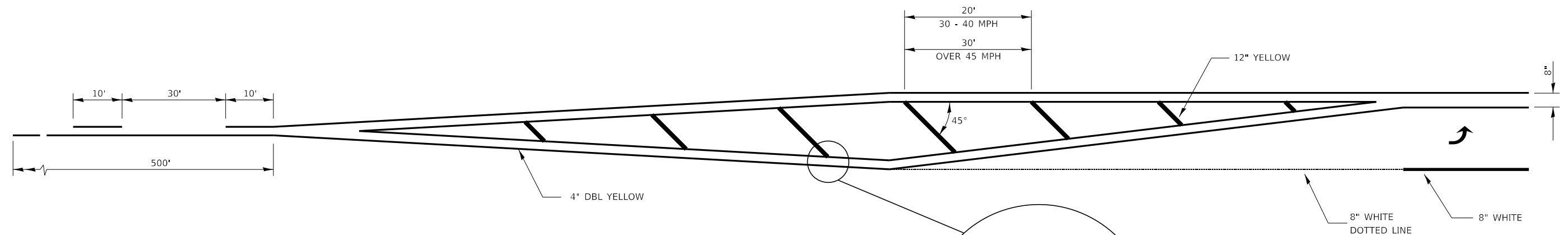

LEFT TURN LANE WITH APPROACH MEDIAN

MODEL: Default
 FILE: \\mshpc-pw01\B84EBIDN\TEC\Illinois\pvc\pvd\DOT\Documents\1\DOT - Offices\1\12111\316168\CADD\1\101316168-08-28-17-cover.dgn

USER NAME = woodshankr1	DESIGNED -	REVISED -
	DRAWN -	REVISED -
PLOT SCALE = 100,0000' / in.	CHECKED -	REVISED -
PLOT DATE = 8/30/2017	DATE -	REVISED -

STATE OF ILLINOIS
 DEPARTMENT OF TRANSPORTATION

PAVEMENT MARKING DETAILS

SCALE: SHEET 4 OF 8 SHEETS STA. TO STA.

F.A. RTE.	SECTION	COUNTY	TOTAL SHEETS	SHEET NO.
VARIOUS	D3 H-T PVMNT MRK RPR 18-30	VARIOUS	15	11
CONTRACT NO. 46468				
ILLINOIS FED. AID PROJECT				

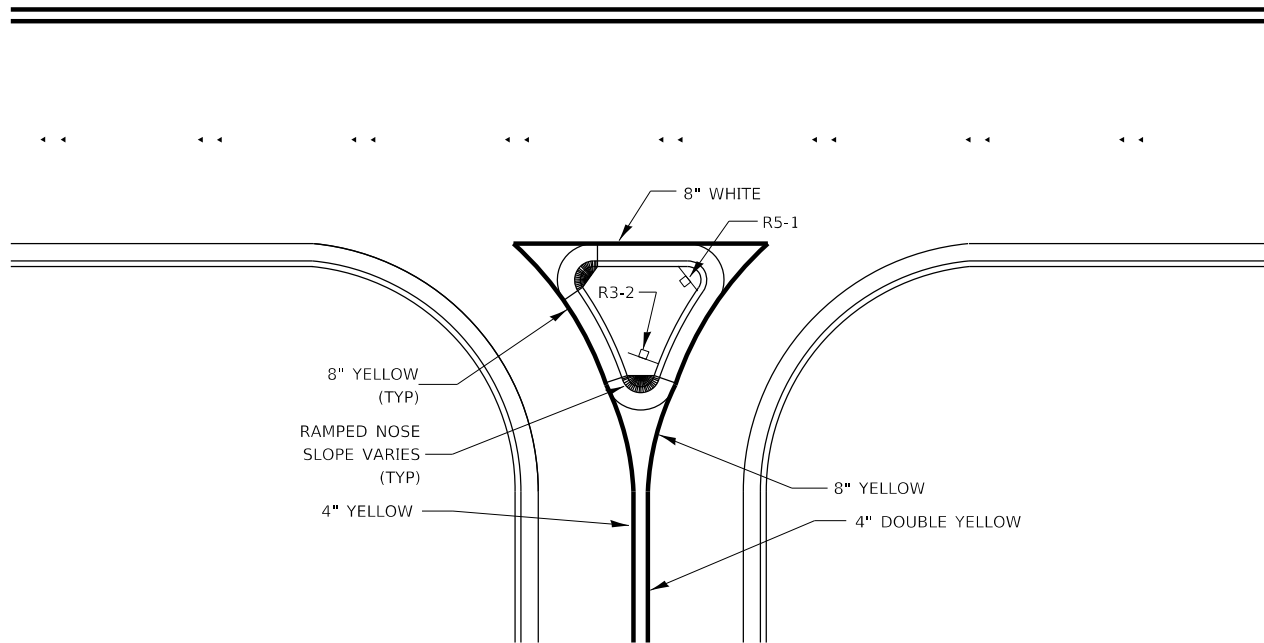

RIGHT IN RIGHT OUT ACCESS PAVEMENT MARKING

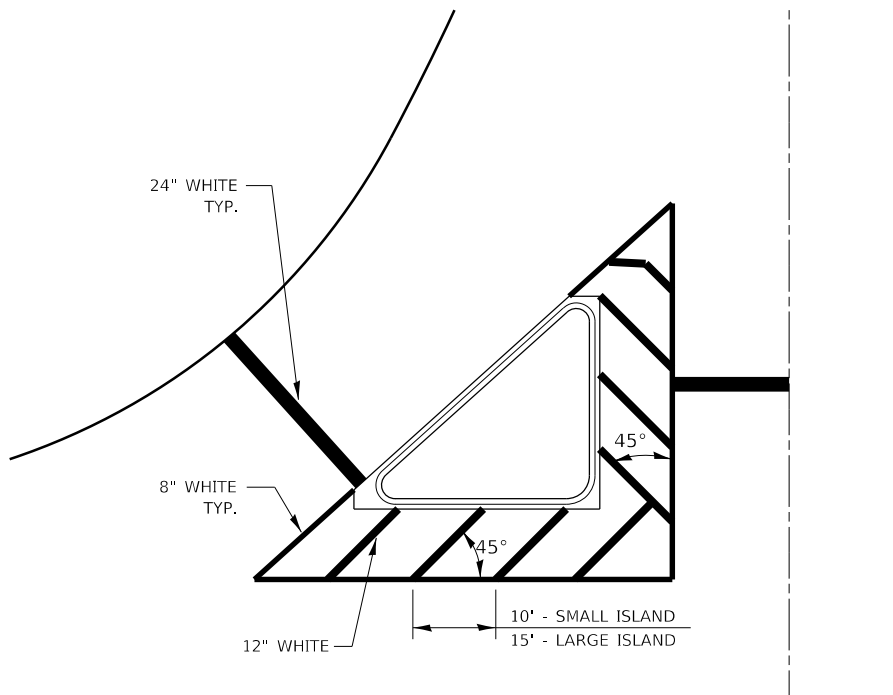

TYPICAL ISLAND

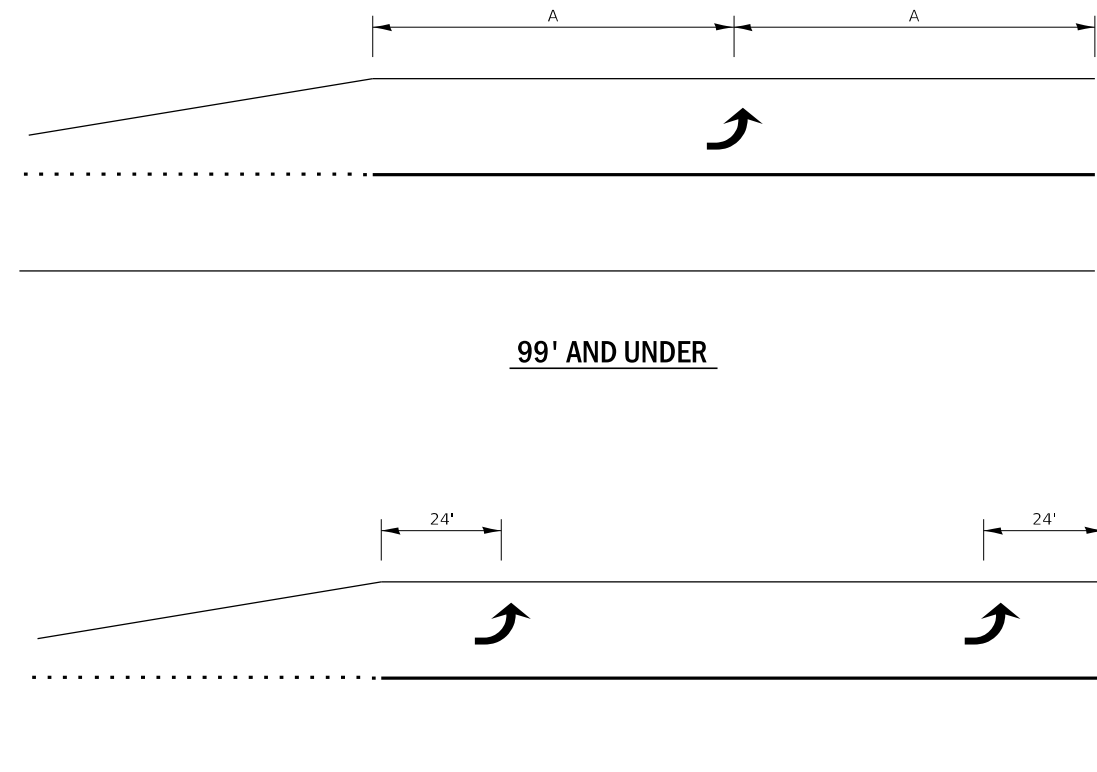

99' AND UNDER

100' TO 149'

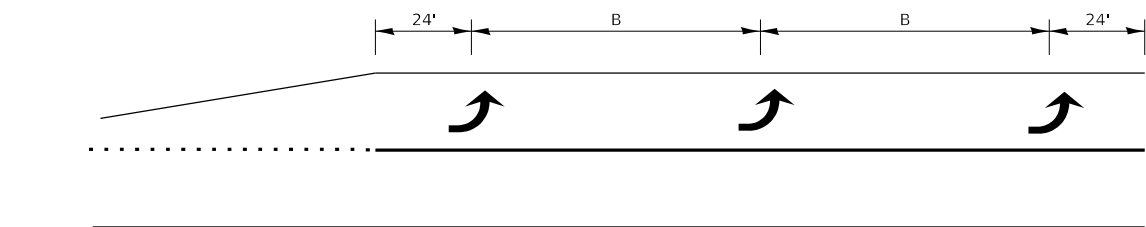

150' AND LONGER

**TYPICAL PLACEMENT OF ARROWS
IN TURN LANES**

MODEL: Default
FILE: Name: p:\u00b98\B&E\BIDD\TEC\Illinois\pwr\DOT\Documents\1\DOT_Offices\Illinet\3\projects\0316468\CADD\0316468-shc-cover.com

USER NAME = woodshankrl	DESIGNED -	REVISED -
DRAWN -	DRAWN -	REVISED -
PLOT SCALE = 100,0000' / in.	CHECKED -	REVISED -
PLOT DATE = 8/30/2017	DATE -	REVISED -

**STATE OF ILLINOIS
DEPARTMENT OF TRANSPORTATION**

PAVEMENT MARKING DETAILS			
SCALE:	SHEET 5 OF 8 SHEETS	STA.	TO STA.

F.A. RTE.	SECTION	COUNTY	TOTAL SHEETS	SHEET NO.
VARIOUS	D3 H-T PVMNT MRK RPR 18-30	VARIOUS	15	12
CONTRACT NO. 46468				
			ILLINOIS	FED. AID PROJECT

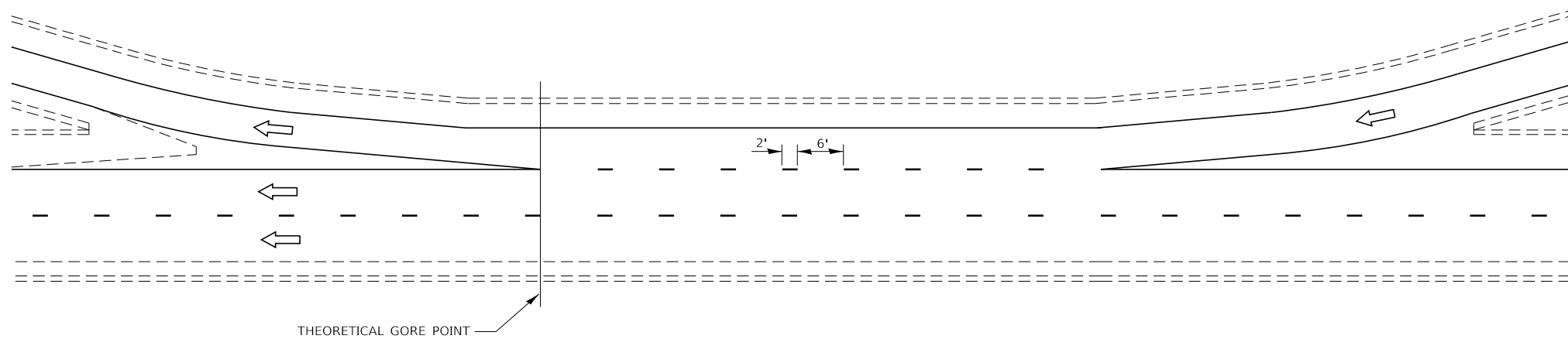

TYPICAL CLOVERLEAF LOOP RAMP MARKINGS

MODEL: Default
 FILE: \\nashville\pub\illinois\pvt\pvd\dot\documents\dot\office\dl\erick\3\projects\0316168\CADD\0316168-ct-cloverc.dwg

USER NAME = woodshankrl	DESIGNED -	REVISED -
	DRAWN -	REVISED -
PLOT SCALE = 100.0000 ' / in.	CHECKED -	REVISED -
PLOT DATE = 8/30/2017	DATE -	REVISED -

**STATE OF ILLINOIS
 DEPARTMENT OF TRANSPORTATION**

PAVEMENT MARKING DETAILS			
SCALE:	SHEET 6	OF 8	SHEETS
	STA.		TO STA.

F.A. RTE.	SECTION	COUNTY	TOTAL SHEETS	SHEET NO.
VARIOUS	D3 H-T PVMNT MRK RPR 18-30		15	13
			CONTRACT NO. 46468	
		ILLINOIS	FED. AID PROJECT	

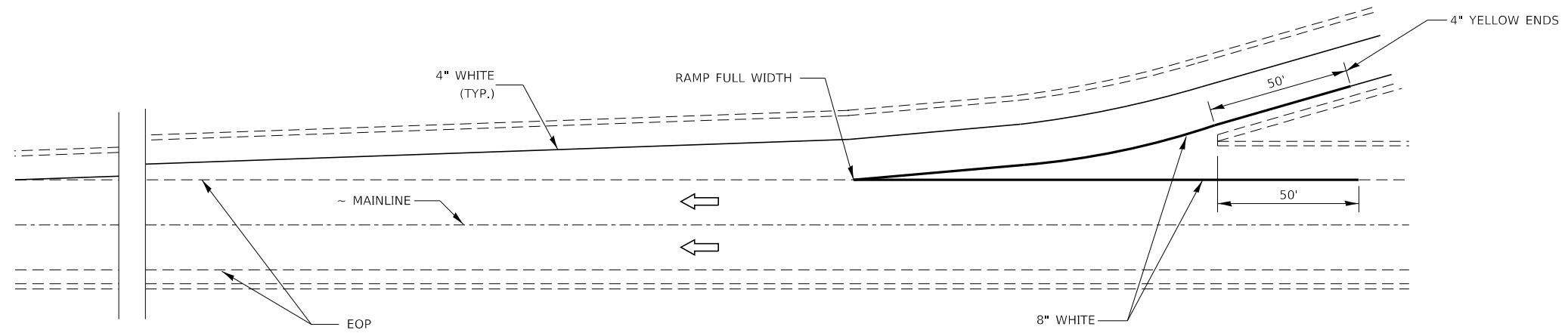

TYPICAL PAVEMENT MARKING FOR ENTRANCE RAMP TERMINALS

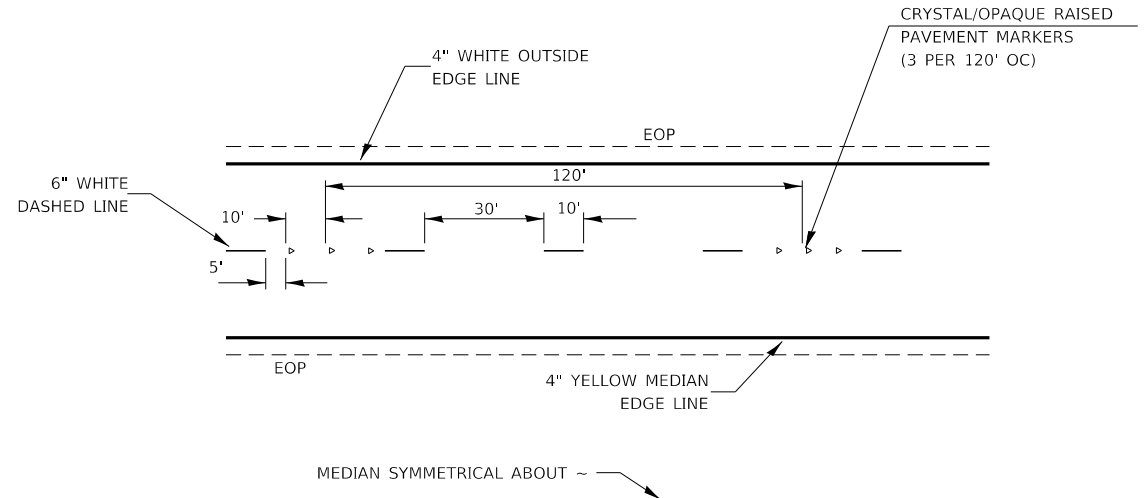

TYPICAL PAVEMENT MARKINGS

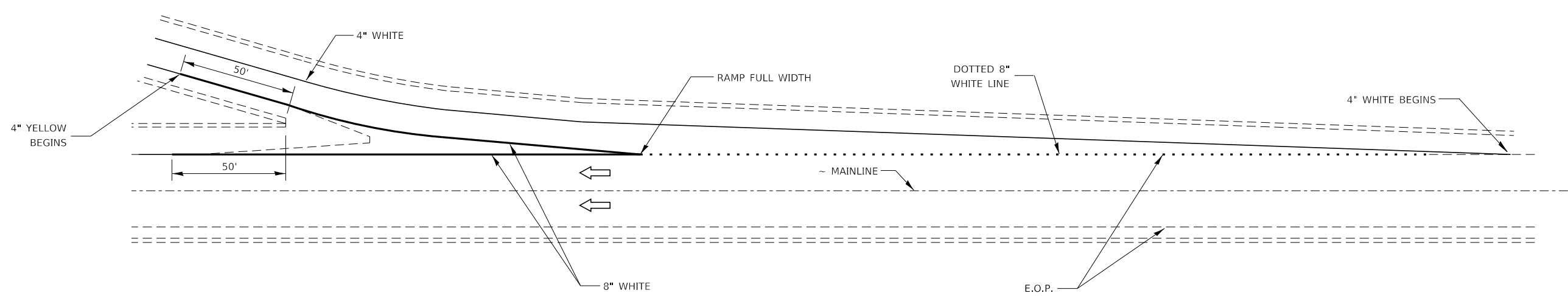

TYPICAL PAVEMENT MARKINGS FOR EXIT RAMP TERMINALS

FOR INTERSTATE 39 (I-39) ONLY

MODEL: Default
 FILE NAME: p:\u1108\BIDD\NTEC\Illinois\gov\PIV\DOT\Documents\11DOT_Offices\11dier\1 3\proj\cs\03\146\168\CAD\03\10\146\168-sh-cover.dwg

USER NAME = woodshankr	DESIGNED -	REVISED -
DRAWN -	REVISIED -	
PLOT SCALE = 100,0000 ' / in.	CHECKED -	REVISIED -
PLOT DATE = 8/30/2017	DATE -	REVISIED -

**STATE OF ILLINOIS
DEPARTMENT OF TRANSPORTATION**

PAVEMENT MARKING DETAILS			
SCALE:	SHEET 7	OF 8 SHEETS	STA. TO STA.

F.A. RTE.	SECTION	COUNTY	TOTAL SHEETS	SHEET NO.
VARIOUS	D3 H-T PVMNT MRK RPR 18-30	VARIOUS	15	14
CONTRACT NO. 46468				
ILLINOIS FED. AID PROJECT				

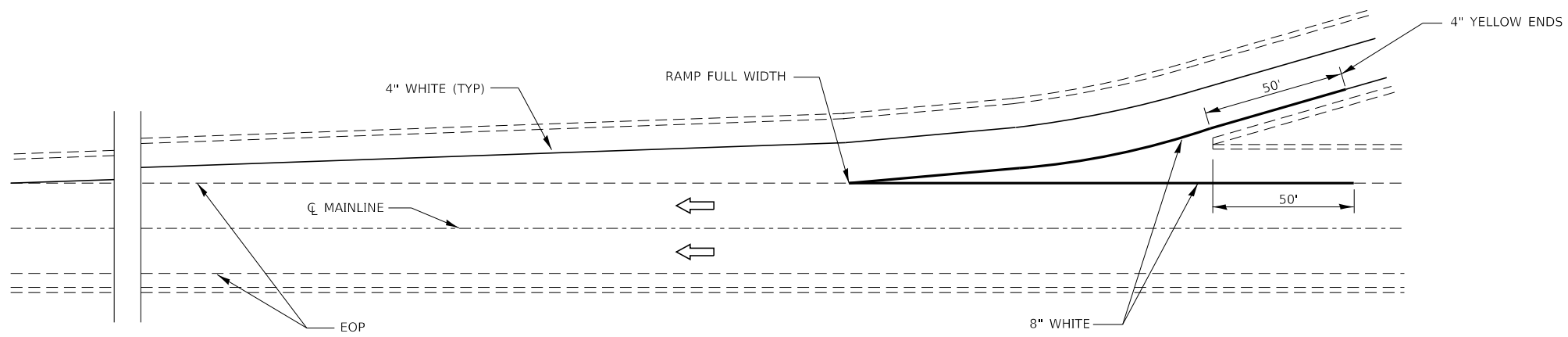

TYPICAL PAVEMENT MARKING FOR ENTRANCE RAMP TERMINALS

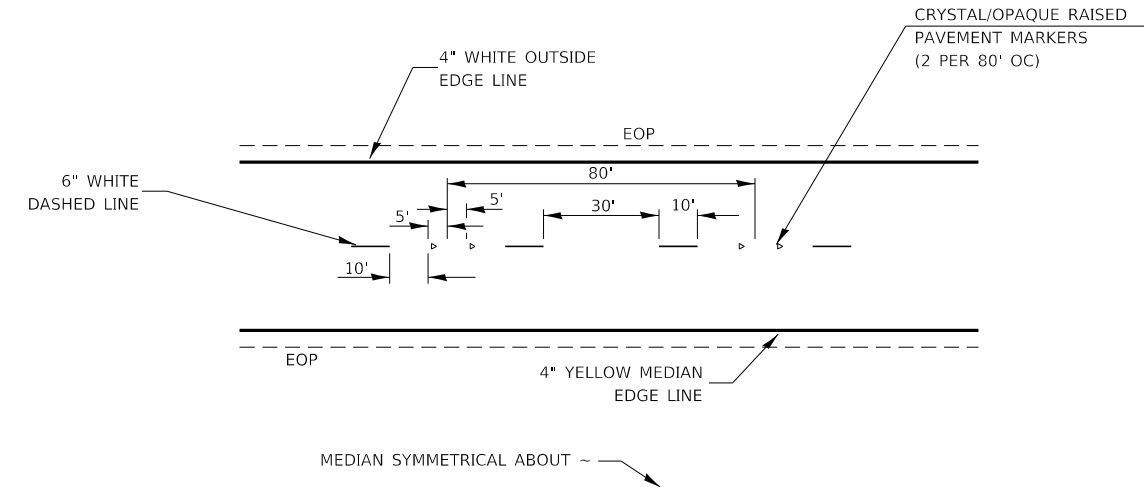

TYPICAL PAVEMENT MARKINGS

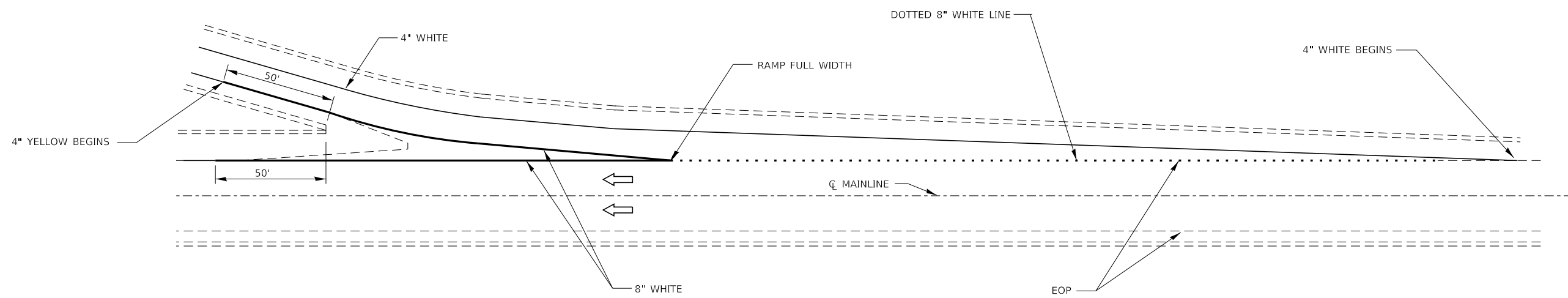

TYPICAL PAVEMENT MARKINGS FOR EXIT RAMP TERMINALS

FOR ALL INTERSTATES

MODEL: Default
 FILE: \\nas01c.pva.us:IL08AEBIDNITC\Illinois.gov\PIVDOT\Documents\DOT_Offices\Director_3\Projects\03146468\COAD\03146468-R01-Cover.dwg

USER NAME = woodshankr1	DESIGNED -	REVISED -
PLOT SCALE = 100.0000' / in.	DRAWN -	REVISIED -
PLOT DATE = 8/30/2017	CHECKED -	REVISIED -
	DATE -	REVISIED -

**STATE OF ILLINOIS
 DEPARTMENT OF TRANSPORTATION**

PAVEMENT MARKING DETAILS			
SCALE:	SHEET 8	OF 8	SHEETS
	STA.		TO STA.

F.A. RTE.	SECTION	COUNTY	TOTAL SHEETS	SHEET NO.
VARIOUS	D3 H-T PVMNT MRK RPR 18-30		15	15
CONTRACT NO. 46468				
ILLINOIS FED. AID PROJECT				