

STATE OF ILLINOIS  
DEPARTMENT OF TRANSPORTATION

F.A.U. RTE.	SECTION	COUNTY	TOTAL SHEETS	SHEET NO.
9677	(13-1,27) RS-2	JACKSON	20	1
		ILLINOIS	CONTRACT NO. 78929	

FOR INDEX OF SHEETS, SEE SHEET NO. 3  
FOR SUMMARY OF QUANTITIES, SEE SHEET NO. 5-7

# PROPOSED HIGHWAY PLANS

FAU ROUTE 9677 (N 6TH ST.)  
SECTION (13-1,27) RS-2  
PROJECT STP-L43Q(523)  
RESURFACING  
JACKSON COUNTY

C-99-035-22

### TRAFFIC DATA

FAU 9677: MP 0.00 TO MP 0.75 SOUTH OF IL. 13/127 INTERSECTION			
	2017	2029	2039
PV =	2,850	3,210	3,550
SU =	70	85	90
MU =	30	55	60
ADT =	2,950	3,350	3,700

**TOWNSHIPS**  
MURPHYSBORO  
SOMERSET

DESIGN DESIGNATION: N/A  
COORDINATE SYSTEM: EPSG: 102672 - NAD 1983  
STATE PLANE ILLINOIS EAST FIPS 1202 WEST  
POSTED SPEED: F.A.U. 9677 (6TH ST.) - 40 MPH (JOHN ST. TO IL. 127)  
F.A.U. 9677 (6TH ST.) - 35 MPH (DEWITTE ST TO JOHN ST.)

J.U.L.I.E.  
JOINT UTILITY LOCATION INFORMATION FOR EXCAVATION  
1-800-892-0123  
OR 811

PROJECT ENGINEER SUSAN POE  
PROJECT DESIGNER HUNTER ZEIGLER

CONTRACT NO. 78929

END STATION 52+44  
N 6TH ST. (FAU 9677)

START STATION 13+08  
N 6TH ST. (FAU 9677)

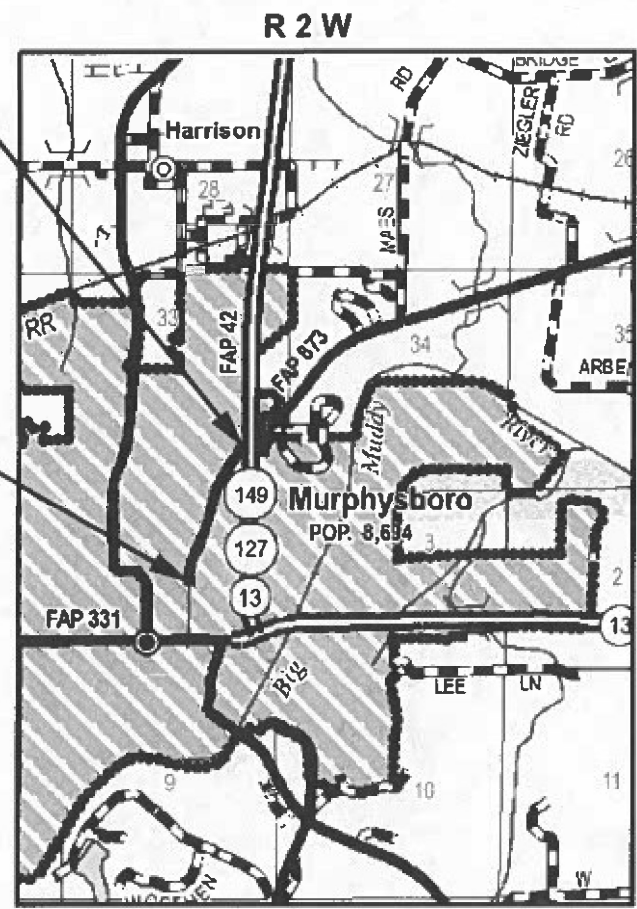

GROSS LENGTH = 3936 FT. = 0.745 MILES  
NET LENGTH = 3936 FT. = 0.745 MILES

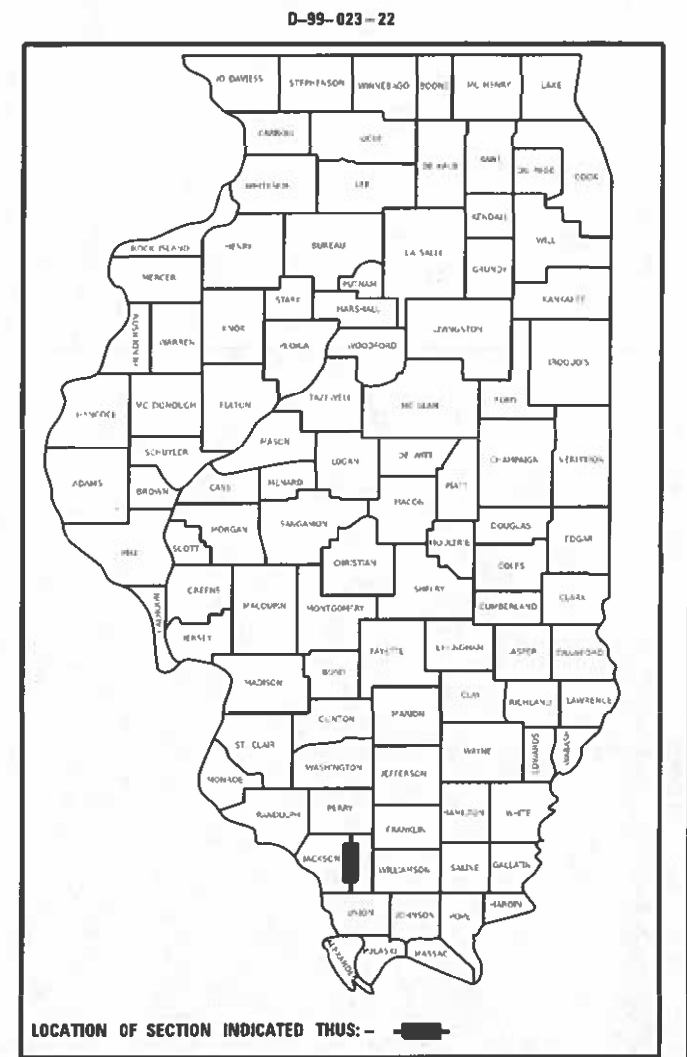

STATE OF ILLINOIS  
DEPARTMENT OF TRANSPORTATION

SUBMITTED August 9 20 23  
Kirk H. Brown  
REGION FIVE ENGINEER

October 13, 2023  
Scott A. Elk  
ENGINEER OF DESIGN AND ENVIRONMENT

October 13, 2023  
Stephen M. Smith  
DIRECTOR OF HIGHWAYS PROJECT IMPLEMENTATION

PRINTED BY THE AUTHORITY  
OF THE STATE OF ILLINOIS



## GENERAL NOTES

FACTORS USED FOR ESTIMATING PLAN QUANTITIES ARE AS FOLLOWS AND SHALL NOT BE USED FOR THE BASIS OF FINAL QUANTITIES:

ALL HOT MIX ASPHALT 2.016 TONS/CU. YD.  
 ALL AGGREGATE 2.05 TONS/CU. YD.

THE QUANTITY OF SHORT TERM PAVEMENT MARKING SHOWN IN THE PLANS IS BASED ON ONE APPLICATION EACH FOR THE HMA SURFACE REMOVAL, BINDER COURSE, AND SURFACE COURSE

THE CONTRACTOR SHALL STAMP STATIONING IN THE PROPOSED HOT MIX ASPHALT SURFACE AT 300 FT INTERVALS ON ALTERNATING SIDES OF THE PAVEMENT AND AS DIRECTED BY THE ENGINEER. THE STATION SYMBOL STAMPS USED SHALL BE FURNISHED BY THE CONTRACTOR. THEY SHALL BE 5 1/2 IN. TALL, OF A DESIGN APPROVED BY THE ENGINEER, AND SHALL REMAIN THE PROPERTY OF THE CONTRACTOR.

HMA RESURFACING SHALL BE PLACED IN A SEQUENCE THAT WILL MINIMIZE THE TIME THE CENTERLINE EDGE IS EXPOSED TO TRAFFIC. WHEN AT THE END OF A DAY'S OPERATION THE EXPOSED CENTERLINE EDGE IS GREATER THAN 2,000 FT, THE CONTRACTOR SHALL BE REQUIRED TO PAVE IN THE ADJACENT LANE ON THE FOLLOWING WORK DAY. PRIOR TO WINTER SHUTDOWN, RESURFACING ON ADJACENT LANES IS TO BE BROUGHT UP TO THE SAME ELEVATION.

LONGITUDINAL JOINT SEALANT SHALL BE PLACED UNDER THE HMA SURFACE COURSE

ALL DETECTOR LOOP CORNERS SHALL BE CORE DRILLED 2 IN. MINIMUM DIAMETER EXCEPT THOSE PLACED UNDER RESURFACING. THE DETECTOR LOOP CORNERS PLACED UNDER RESURFACING SHALL BE DIAGONALLY SAWCUT.

ALL DETECTOR LOOPS SHALL BE INSTALLED PRIOR TO RESURFACING.

THE CONTRACTOR SHALL NOTIFY THE ENGINEER OF TRAFFIC OPERATIONS 72 HOURS PRIOR TO THE SHUT-DOWN OR CUTTING OF EXISTING DETECTOR LOOPS.

VIBRATORY ROLLERS WILL NOT BE ALLOWED ON THIS PROJECT

INCIDENTAL HOT-MIX ASPHALT SURFACING SHALL BE PAVED IN A SEPARATE OPERATION FROM THE MAINLINE PAVEMENT

**COMMITMENTS: NONE**

## INDEX OF SHEETS

SHEET NO	DESCRIPTION
1	COVER SHEET
2	SIGNATURE SHEET
3	GENERAL NOTES, INDEX OF SHEETS AND LIST OF HIGHWAY STANDARDS
4	MIX DESIGN
5-7	SUMMARY OF QUANTITIES
8-9	TYPICAL SECTIONS: NORTH 6TH ST. (FAU 9677)
10-12	SCHEDULES
13	INTERSECTION RESURFACING LIMITS
14-15	EXISTING DETECTOR LOOP LOCATIONS - FOR INFORMATION PURPOSES ONLY
16	DETAILS: SIDEROAD DETAIL
17	DETAILS: ENTRANCE DETAIL
18	DETAILS: TRANSITIONS
19	DETAILS: TEMPORARY RAMPS, SHORT TERM PVT MARKING DETAIL
20	DETAILS: DISTRICT STANDARDS

## HIGHWAY STANDARDS

000001-08\_STANDARDSYMBOLSABBREVIATIONS-PATTERNS-001  
 001006\_DECIMALOFINCH-FOOT  
 406201-01\_MAILBOXTURNOUT  
 701001-02\_OFFRDOP-2L2W-15FTMINFROMEOP  
 701006-05\_OFFRDOP-2L2W-15FTTOEOP  
 701011-04\_OFFRDMOVINGOP-2L2W-DAYONLY  
 701301-04\_LNCLOSURE2L2W-SHORTTIMEOP  
 701311-03\_LNCLOSURE2L2W-MOVINGOPDAYONLY  
 701421-08\_LNCLOSUREMULTILN-DAYOPONLY45-55MPH  
 701501-06\_URBANLNCLOSURE2L2W-UNDIVIDED  
 701701-10\_URBANLNCLOSUREMULTILNINTERSECTION  
 701901-08\_TRAFCNTRLDEVICES  
 780001-05\_TYPICALPVMTRKINGS  
 781001-04\_TYPICALAPPRAISEDREFLCPVMTMRKRS  
 886001-01\_DETECTORLOOPINSTALLATIONS  
 886006-01\_TYPICALLAYOUTSFORDETECTIONLOOPS

MODEL: Index of Sheets and Highway Standards (Sheet) FILE NAME: P:\GIS\Projects\78929\CADD\Drawings\DOT\Office\Drawings\DOT\78929-SHB-Index\_GenNotes.dgn

USER NAME = Hunter.Zeigler PLOT SCALE = 0.16666633' / in. PLOT DATE = 7/28/2023	DESIGNED - DRAWN - CHECKED - DATE -	REVISED - REVISED - REVISED - REVISED -	<b>STATE OF ILLINOIS DEPARTMENT OF TRANSPORTATION</b>	<b>GENERAL NOTES, INDEX OF SHEETS, AND HIGHWAY STANDARDS</b>	F.A.U. RTE. 9677	SECTION (13-1,27) RS-2	COUNTY JACKSON	TOTAL SHEETS 20	SHEET NO. 3
SCALE: SHEET 3 OF 20 SHEETS STA. TO STA.				ILLINOIS FED. AID PROJECT					

## HMA MIXTURE REQUIREMENTS

Locations	Hot-Mix Asphalt Surface Course; Incidental Hot-Mix Asphalt Surfacing
Mixture Use(s):	Hot-Mix Asphalt Surface Course, Mix C, N70, 9.5mm
PG:	PG 64-22
Design Air Voids:	4.0 %, 70 Gyration Design
Mixture Composition: (Gradation Mixture)	IL-9.5mm
Friction Aggregate:	Mix C
Mixture Weight:	112 lbs/Sq Yd/in
Quality Management Program:	QCQA
Sublot Size:	3000 Ton
Material Transfer Device (Required?)	No

Locations	Hot-Mix Asphalt Binder Course
Mixture Use(s):	Hot-Mix Binder Course, N70, 9.5FG
AB/PG:	PG64-22
Design Air Voids:	4.0 %, 70 Gyration Design
Mixture Composition: (Gradation Mixture)	IL-9.5mm FG
Friction Aggregate:	None
Mixture Weight:	112 lbs/Sq Yd/in
Quality Management Program:	QCQA
Sublot Size:	3000 Ton
Material Transfer Device (Required?)	No

Locations	Hot-Mix Asphalt Shoulders (1 1/2" and Var. Depth)
Mixture Use(s):	Hot-Mix Asphalt Surface Course, Mix C, N30, 9.5mm FG
AB/PG:	PG64-22
Design Air Voids:	4.0 %, 30 Gyration Design
Mixture Composition: (Gradation Mixture)	IL-9.5mm FG
Friction Aggregate:	Mix C
Mixture Weight:	112 lbs/Sq Yd/in
Quality Management Program:	QCQA
Sublot Size:	3000 Ton
Material Transfer Device (Required?)	No

MODEL: HMA MIXTURE REQUIREMENTS.rvt  
 FILE NAME: P:\Projects\78929\CAD\Drawings\DOT\Office\District 9\ORD Project\78929\CAD\Drawings\DOT\Office\District 9\ORD Project\78929-SHB-Addn\_GenNotes.dgn

USER NAME = Hunter.Zeigler	DESIGNED -	REVISED -
	DRAWN -	REVISED -
PLOT SCALE = 0.16666633' / in.	CHECKED -	REVISED -
PLOT DATE = 7/28/2023	DATE -	REVISED -

**STATE OF ILLINOIS  
DEPARTMENT OF TRANSPORTATION**

**HMA MIXTURE REQUIREMENTS**

SCALE: SHEET 4 OF 20 SHEETS STA. TO STA.

F.A.U. RTE.	SECTION	COUNTY	TOTAL SHEETS	SHEET NO.
9677	(13-1.27) RS-2	JACKSON	20	4
CONTRACT NO. 78929				
ILLINOIS FED. AID PROJECT				

# SUMMARY OF QUANTITIES

COUNTY:	JACKSON CO
ROUTE:	FAU 9677
FUNDING:	80% FEDERAL 20% STATE
LOCATION:	URBAN
	ROADWAY
	0005

CODE NUMBER	ITEM DESCRIPTION	UNIT	TOTAL QUANTITY	
40600290	BITUMINOUS MATERIALS (TACK COAT)	POUND	9,014	9,014
40600370	LONGITUDINAL JOINT SEALANT	FOOT	4,479	4,479
40600982	HOT-MIX ASPHALT SURFACE REMOVAL - BUTT JOINT	SQ YD	958	958
40600990	TEMPORARY RAMP	SQ YD	366	366
40602970	HOT-MIX ASPHALT BINDER COURSE, IL-9.5FG, N70	TON	860	860
40604052	HOT-MIX ASPHALT SURFACE COURSE, IL-9.5, MIX "C", N70	TON	932	932
40800050	INCIDENTAL HOT-MIX ASPHALT SURFACING	TON	139	139
44000155	HOT-MIX ASPHALT SURFACE REMOVAL, 1 1/2"	SQ YD	7,196	7,196
44000161	HOT-MIX ASPHALT SURFACE REMOVAL, 3"	SQ YD	3,963	3,963
48102100	AGGREGATE WEDGE SHOULDER, TYPE B	TON	129	129
48203100	HOT-MIX ASPHALT SHOULDERS	TON	127	127
67000400	ENGINEER'S FIELD OFFICE, TYPE A	CAL MO	2	2
67100100	MOBILIZATION	L SUM	1	1
70100310	TRAFFIC CONTROL AND PROTECTION, STANDARD 701421	L SUM	1	1

MODEL: S00\_6 [B]heif  
 FILE NAME: P:\MIDOT\Documents\IDOT Office\District 9\ORD Project\78929\CAD\Drawings\78929-SUM-Q.dgn

# SUMMARY OF QUANTITIES - CONT

COUNTY:	JACKSON CO
ROUTE:	FAU 9677
FUNDING:	80% FEDERAL 20% STATE
LOCATION:	URBAN
	ROADWAY
	0005

CODE NUMBER	ITEM DESCRIPTION	UNIT	TOTAL QUANTITY	
70102620	TRAFFIC CONTROL AND PROTECTION, STANDARD 701501	L SUM	1	1
70102635	TRAFFIC CONTROL AND PROTECTION, STANDARD 701701	L SUM	1	1
70107025	CHANGEABLE MESSAGE SIGN	CAL DA	28	28
70300100	SHORT TERM PAVEMENT MARKING	FOOT	1,968	1,968
70300150	SHORT TERM PAVEMENT MARKING REMOVAL	SQ FT	219	219
70300211	TEMPORARY PAVEMENT MARKING LETTERS AND SYMBOLS - PAINT	SQ FT	73	73
70300221	TEMPORARY PAVEMENT MARKING - LINE 4"- PAINT	FOOT	13,494	13,494
70300261	TEMPORARY PAVEMENT MARKING - LINE 12"- PAINT	FOOT	324	324
70300281	TEMPORARY PAVEMENT MARKING - LINE 24"- PAINT	FOOT	46	46
* 78001100	PAINT PAVEMENT MARKING - LETTERS AND SYMBOLS	SQ FT	73	73
* 78001110	PAINT PAVEMENT MARKING - LINE 4"	FOOT	13,494	13,494
* 78001150	PAINT PAVEMENT MARKING - LINE 12"	FOOT	324	324
* 78001180	PAINT PAVEMENT MARKING - LINE 24"	FOOT	46	46
* 78100100	RAISED REFLECTIVE PAVEMENT MARKER	EACH	101	101

\* SPECIALTY ITEM

MODEL: S00\_7 [B]heif  
 FILE NAME: P:\MIDOT\Documents\IDOT Office\District 9\ORD Project\78929\CAD\Drawings\78929-SUM-500.dgn

## SUMMARY OF QUANTITIES - CONT

COUNTY:	JACKSON CO
ROUTE:	FAU 9677
FUNDING:	80% FEDERAL 20% STATE
LOCATION:	URBAN
TOTAL QUANTITY	ROADWAY 0005

CODE NUMBER	ITEM DESCRIPTION	UNIT	TOTAL QUANTITY	ROADWAY
78300200	RAISED REFLECTIVE PAVEMENT MARKER REMOVAL	EACH	32	32
78300201	PAVEMENT MARKING REMOVAL - GRINDING	SQ FT	4,987	4,987
* 88600100	DETECTOR LOOP, TYPE I	FOOT	419	419

\* SPECIALTY ITEM

REV. - MS

MODEL: S00\_01 (Rev. 01)  
 FILE NAME: P:\2023\Projects\DOT\Documents\DOT\Office\Drawings\DOT\Projects\78929\Drawings\DOT\78929-S00.dgn

USER NAME = Hunter Zeigler	DESIGNED -	REVISED -
	DRAWN -	REVISED -
PLOT SCALE = 0.16666633 / in.	CHECKED -	REVISED -
PLOT DATE = 8/4/2023	DATE -	REVISED -

**STATE OF ILLINOIS  
DEPARTMENT OF TRANSPORTATION**

### SUMMARY OF QUANTITIES

SCALE: SHEET 7 OF 20 SHEETS STA. TO STA.

FAU RTE.	SECTION	COUNTY	TOTAL SHEETS	SHEET NO.
9677	(13-1,27) RS-2	JACKSON	20	7
ILLINOIS   FED. AID PROJECT			CONTRACT NO. 78929	

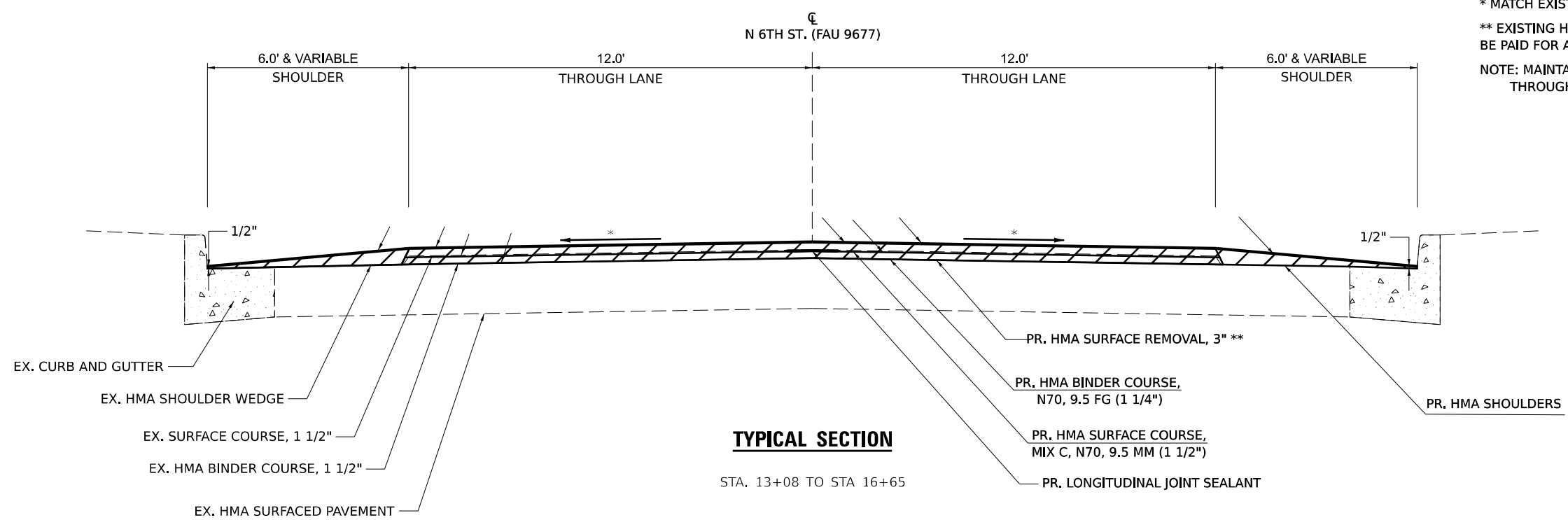

\* MATCH EXISTING SLOPE  
 \*\* EXISTING HMA SHOULDER WEDGE REMOVAL TO BE PAID FOR AS HMA SURFACE REMOVAL, 3"  
 NOTE: MAINTAIN EXISTING RATE OF SLOPE THROUGH LIMITS OF EXISTING S.E. PAV'T.

**TYPICAL SECTION**

STA. 13+08 TO STA 16+65

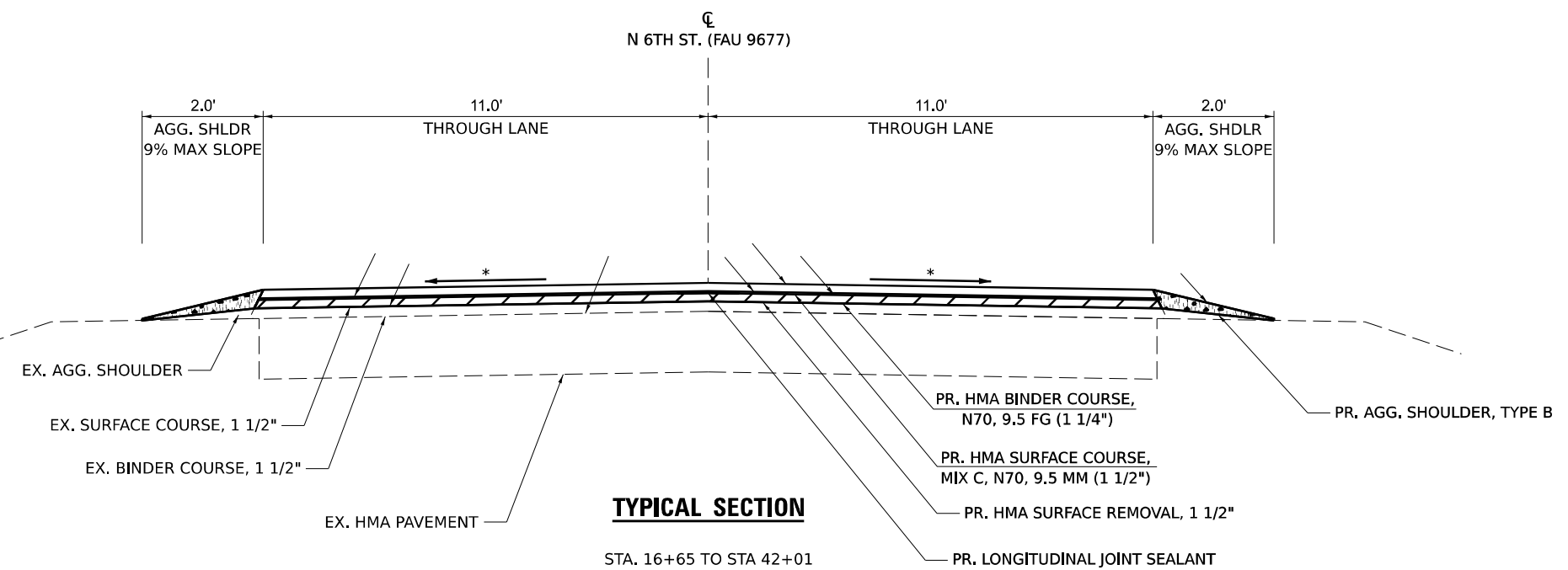

**TYPICAL SECTION**

STA. 16+65 TO STA 42+01

MODEL: Typical Section 1 (Sheet)  
 FILE NAME: P:\GIS\Projects\GIS\DOT\Office\District 9\ORD Project\78929\CADD\Drawings\DOT\78929-SHE-Typical.dgn

USER NAME = Hunter.Zeigler	DESIGNED -	REVISED -
PLOT SCALE = 0.16666633' / in.	DRAWN -	REVISED -
PLOT DATE = 7/28/2023	CHECKED -	REVISED -
	DATE -	REVISED -

**STATE OF ILLINOIS  
DEPARTMENT OF TRANSPORTATION**

<b>TYPICAL SECTIONS</b>			
SCALE:	SHEET 8	OF 20 SHEETS	STA. TO STA.

F.A.U. RTE.	SECTION	COUNTY	TOTAL SHEETS	SHEET NO.
9677	(13-1,27) RS-2	JACKSON	20	8
CONTRACT NO. 78929				
ILLINOIS FED. AID PROJECT				



\* MATCH EXISTING SLOPE  
 \*\* APPLY LONGITUDINAL JOINT SEALANT TO ALL LONGITUDINAL JOINTS RESULTING FROM THE PAVING OPERATION. THE TRAVELED WAY/SHOULDER JOINT LONGITUDINAL JOINT SEALANT SHALL BE OMITTED.  
 NOTE: MAINTAIN EXISTING RATE OF SLOPE THROUGH LIMITS OF EXISTING S.E. PAV'T.

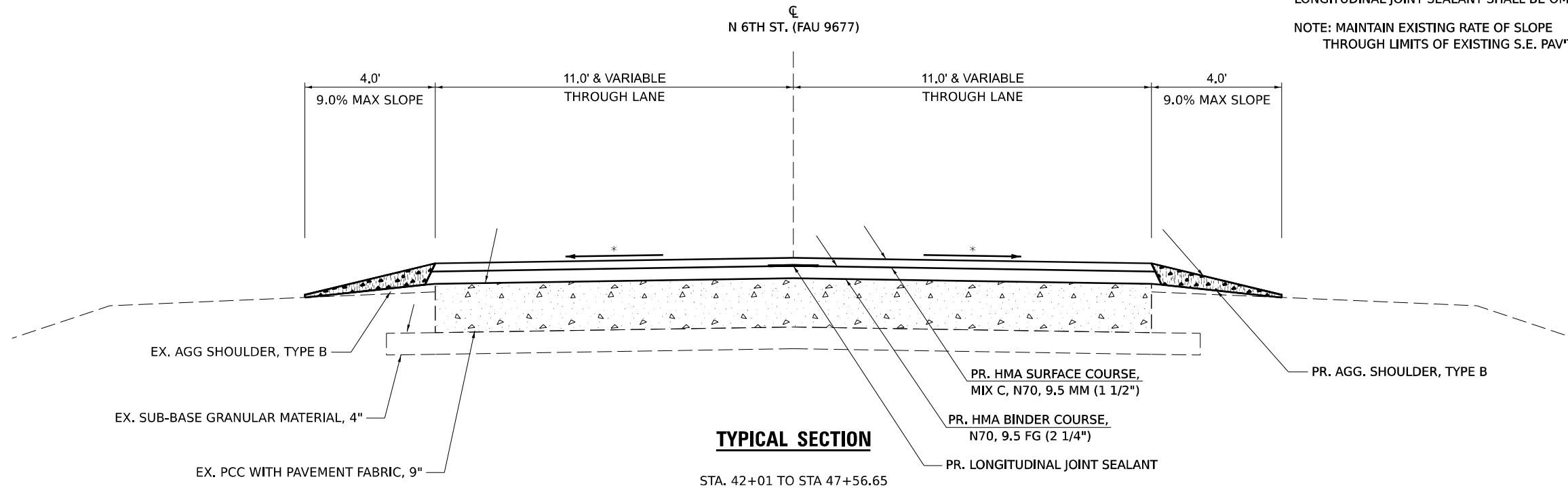

**TYPICAL SECTION**

STA. 42+01 TO STA 47+56.65

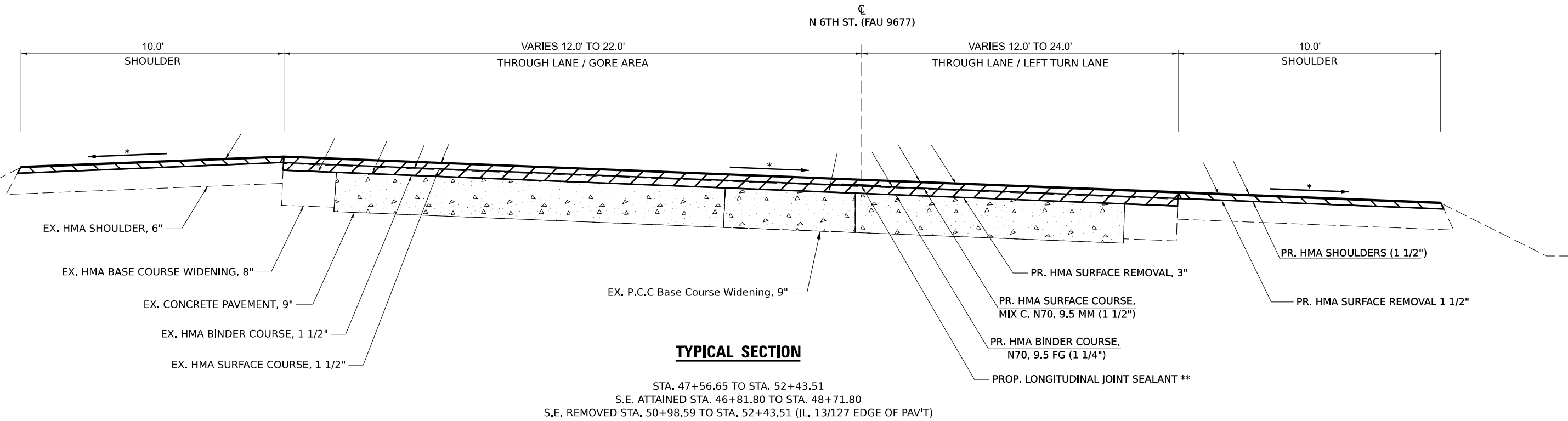

**TYPICAL SECTION**

STA. 47+56.65 TO STA. 52+43.51  
 S.E. ATTAINED STA. 46+81.80 TO STA. 48+71.80  
 S.E. REMOVED STA. 50+98.59 TO STA. 52+43.51 (IL. 13/127 EDGE OF PAV'T)

MODEL: Typical Section 2 (Sheet)  
 FILE NAME: P:\GIS\Projects\2023\13-127\13-127-2\13-127-2-Typical.dgn

USER NAME = Hunter.Zelger	DESIGNED -	REVISED -
PLOT SCALE = 0.16666833' / in.	DRAWN -	REVISED -
PLOT DATE = 7/28/2023	CHECKED -	REVISED -
	DATE -	REVISED -

**STATE OF ILLINOIS  
 DEPARTMENT OF TRANSPORTATION**

<b>TYPICAL SECTIONS</b>			
SCALE:	SHEET 9	OF 20 SHEETS	STA. TO STA.

F.A.U. RTE.	SECTION	COUNTY	TOTAL SHEETS	SHEET NO.
9677	(13-1,27) RS-2	JACKSON	20	9
CONTRACT NO. 78929				
ILLINOIS FED. AID PROJECT				

## N 6TH ST. (FAU 9677) MAINLINE RESURFACING SCHEDULE

LOCATION STATION TO STATION	LENGTH	ROADWAY WIDTH	HMA SURFACE REMOVAL, 3"	HMA SURFACE REMOVAL, 1 1/2"	HMA BINDER COURSE, IL-9.5FG, N70 (2 1/4")	HMA BINDER COURSE, IL-9.5FG, N70 (1 1/4")	HMA SURFACE COURSE, MIX C, IL-9.5, N70 (1 1/2")	BIT. MATERIALS (TACK COAT)	LONG. JOINT SEALANT	TEMP. RAMP	COMMENTS
N 6TH ST. (FAU 9677)	(FT)	(FT)	SQ YD	SQ YD	TON	TON	TON	POUND	FOOT	SQ YD	
13+08										64	RAMP QTY INCLUDES RAMPS FOR BOTH MILLED SURF. & BINDER LIFT
13+08 TO 16+65	357	24	952			68	80	643	357		12' Lanes, 6' & VAR SHOULDERS, SEE SHOULDER SCHEDULE FOR QTY
16+65 TO 42+01	2536	22		6199		441	524	4184	2536		1 1/4" GRADE RAISE
42+01 TO 47+56	555	22			174		115	917	555		NO REMOVAL, OVERLAY ON BARE CONCRETE.
47+56 TO 52+44	488	VARIES	2535			177	213	1711	1031		INLAY AT THE INTERSECTION WITH IL.13/127
52+44										200	RAMP QTY INCLUDES RAMPS FOR BOTH MILLED SURF. & BINDER LIFT
<b>TOTALS</b>			3487	6199	174	686	932	7455	4479	264	

## N 6TH ST. (FAU 9677) SHOULDER SCHEDULE

LOCATION STATION TO STATION	LENGTH	HMA SHOULDER WIDTH		HMA SURFACE REMOVAL, 1 1/2"	HMA SURFACE REMOVAL, 3"	HOT-MIX ASPHALT SHOULDERS	BITUMINOUS MATERIALS (TACK COAT)	AGG WEDGE SHOULDER, TYPE B	COMMENTS
		LT.	RT.						
		FOR INFORMATION ONLY							
N 6TH ST. (FAU 9677)	(FT)	(FT)	(FT)	(SQ YD)	(SQ YD)	(TON)	(LBS)	(TON)	
13+08 TO 16+44	336	6' & VAR.	6' & VAR.		476	43	321	0	SHDLR ENDS RT SIDE +/- STA. 16+85
16+44 TO 42+01	2557							87	AGG. WEDGE STARTS +/- STA. 16+85
42+01 TO 47+56	555							42	AGG. WEDGE WIDENS TO 4'
47+56 TO 52+44	488	10' & Var.	10' & Var.	997		84	673	0	1 3/2" HMA SHOULDER DEPTH
<b>TOTALS</b>				997	476	127	994	129	

MODEL: S00\_1 [Sheet]  
 FILE NAME: P:\GIS\Projects\9677\9677\_Sched\9677\_Sched.dwg

USER NAME = Hunter.Zeigler	DESIGNED -	REVISED -
	DRAWN -	REVISED -
PLOT SCALE = 0.16666633' / in.	CHECKED -	REVISED -
PLOT DATE = 8/4/2023	DATE -	REVISED -

**STATE OF ILLINOIS  
DEPARTMENT OF TRANSPORTATION**

**SCHEDULES**

SCALE: SHEET 10 OF 20 SHEETS STA. TO STA.

FAU RTE.	SECTION	COUNTY	TOTAL SHEETS	SHEET NO.
9677	(13-1,27) RS-2	JACKSON	20	10
CONTRACT NO. 78929				
ILLINOIS FED. AID PROJECT				

## N 6TH ST. (FAU 9677) ENTRANCE AND SIDEROAD SCHEDULE

LOCATION (STATION)	WIDTH AT EDGE OF PAVEMENT	DISTANCE BEHIND EDGE OF PAVEMENT	WIDTH AT DISTANCE BEHIND EDGE OF PAVEMENT	ROADWAY AREA	HOT-MIX ASPHALT SURFACE REMOVAL - BUTT JOINT	INCIDENTAL HOT-MIX ASPHALT SURFACING	BITUMINOUS MATERIALS (TACK COAT)	TEMPORARY RAMP	COMMENTS				
										FOR INFORMATIONAL PURPOSES ONLY			
										FOOT	FOOT	FOOT	SQ YD
14+63	RT	47	15	25	60.0	60	5.0	27	9	BIT. SIDEROAD (DEWITTE ST.)			
15+74	RT									AGG. PRIVATE ENTRANCE (PULL SHOULDER THROUGH)			
16+61	LT	50	15	26	63.3	63	5.3	29	12	BIT. SIDEROAD (CITY ST.)			
16+74	RT									BIT. PRIVATE ENTRANCE (PULL SHOULDER THROUGH)			
18+74	LT	35	4	24	13.1		0.6	6		BIT. PRIVATE ENTRANCE			
22+50	RT	58	15	26	70.0	70	5.9	32	7	BIT. SIDEROAD (JOHN ST.)			
22+50	LT	48	15	20	56.7	57	4.8	26	5	BIT. SIDEROAD (JOHN ST.)			
24+52	RT	36	4	30	14.7		0.7	7		BIT. PRIVATE ENTRANCE (PITTMAN LANE)			
25+49	RT	37	4	30	14.9		0.7	7		BIT. PRIVATE ENTRANCE			
26+70	RT	56	4	47	22.9		1.1	10		BIT. PRIVATE ENTRANCE			
28+95	LT	39	4	29	15.1		0.7	7		BIT. PRIVATE ENTRANCE			
30+23	RT	37	4	26	14		0.7	6		BIT. PRIVATE ENTRANCE			
30+71	LT	40	15	20	50.0	50	4.4	23	5	BIT. SIDEROAD (MAPLE ST.)			
31+24	RT	43	4	31	16.4		0.8	7		BIT. PRIVATE ENTRANCE			
31+68	RT	41	4	27	15.1		0.7	7		BIT. PRIVATE ENTRANCE			
32+02	LT	35	4	30	14.4		0.7	7		BIT. PRIVATE ENTRANCE			
32+74	RT	39	4	28	14.9		0.7	7		BIT. PRIVATE ENTRANCE			
32+78	LT	42	4	34	16.9		0.8	8		BIT. PRIVATE ENTRANCE			
33+43	LT	31	4	23	12		0.6	5		BIT. PRIVATE ENTRANCE			
33+82	LT	33	4	27	13.3		0.7	6		BIT. PRIVATE ENTRANCE			
34+46	RT	71	4	55	28.0		1.4	13		BIT. PRIVATE ENTRANCE (PORTER LANE)			
35+36	LT	43	4	37	17.8		0.9	8		BIT. PRIVATE ENTRANCE			
36+32	LT	110	15	59	140.8	141	11.8	63	11	BIT. SIDEROAD (ILLINOIS AVE)			
37+51	LT	44	4	33	17.1		0.8	8		BIT. PRIVATE ENTRANCE			
39+80	LT	38	4	27	14.4		0.7	7		AGG. PRIVATE ENTRANCE			
40+81	LT	33	4	30	14		0.7	6		BIT. PRIVATE ENTRANCE			
43+58	LT	127	15	74	167.5	168	24.7	75	18	BIT. SIDEROAD (SOMERSET ST.)			
45+59	RT	76	10	56	73.3	73	10.8	33	5	BIT. PRIVATE ENTRANCE			
45+91	LT	60	10	43	57.2	57	8.4	26	5	BIT. PRIVATE ENTRANCE			
46+45	RT	92	10	58	83.3	83	17.5	38	10	AGG. COMMERCIAL ENTRANCE			
46+99	LT	102	10	75	98.3	98	20.7	44	10	AGG. COMMERCIAL ENTRANCE			
47+62	RT	39	10	29	37.8	38	5.6	17	5	CONCRETE COMMERCIAL ENTRANCE			
48+58	LT									BIT. COMMERCIAL ENTRANCE (PULL SHOULDER THROUGH)			
<b>TOTALS</b>						958	139	565	102				

MODEL: S00\_5 [Sheet]  
 FILE NAME: P:\MIDOT\Documents\DOT Office\District 9\ORD Project\9677\CADD\CAD\Sheet\04-78929-SRD-Schedule.dgn

USER NAME = Hunter.Zeigler	DESIGNED -	REVISED -
PLOT SCALE = 0.16666633' / in.	DRAWN -	REVISED -
PLOT DATE = 7/28/2023	CHECKED -	REVISED -
	DATE -	REVISED -

**STATE OF ILLINOIS  
DEPARTMENT OF TRANSPORTATION**

**SCHEDULES**

SCALE: SHEET 11 OF 20 SHEETS STA. TO STA.

FAU RTE.	SECTION	COUNTY	TOTAL SHEETS	SHEET NO.
9677	(13-1,27) RS-2	JACKSON	20	11
CONTRACT NO. 78929				
ILLINOIS FED. AID PROJECT				

## N 6TH ST. (FAU 9677) PAVEMENT MARKING SCHEDULE

LOCATION STATION TO STATION	PAINT-PAVEMENT MARKING							LETTERS & SYMBOLS	RAISED REFLECTIVE PAVEMENT MARKER REMOVAL	RAISED REFLECTIVE PAVEMENT MARKER	COMMENTS
	LINE 4"			LINE 12"		LINE 24"					
	SOLID	SOLID	SKIP DASH	SOLID	SOLID	SOLID					
	WHITE	YELLOW	YELLOW	WHITE	YELLOW	WHITE					
N 6TH ST. (FAU 9677) - URBAN	FOOT	FOOT	FOOT	FOOT	FOOT	FOOT	FOOT	SQ FT	EACH	EACH	
13+00 TO 17+63	834	455	120							11	11 RRPM'S-TWO WAY AMBER
17+63 TO 23+63	1106	1200								11	11 RRPM'S-TWO WAY AMBER
23+63 TO 32+05	1648	842	220							18	18 RRPM'S-TWO WAY AMBER
32+05 TO 40+59	1592		220							16	16 RRPM'S-TWO WAY AMBER
40+59 TO 46+52	1088	593	150							10	10 RRPM'S-TWO WAY AMBER
46+52 TO 52+44	1652	1774		169	155		46	73	32	35	MATCHING EXISTING RRPM'S
<b>SUB-TOTALS</b>	7920	4864	710	169	155		46	73	32	101	
<b>TOTALS</b>	13494			324			46	73	32	101	

## N 6TH ST. (FAU 9677) DETECTOR LOOP SCHEDULE (1 OF 1)

Location		NUMBER OF LOOPS CONNECTED IN SERIES	LOOP SIZE			ADDITIONAL SAWCUT LENGTH	LOOP AMOUNT	DETECTOR LOOP, TYPE 1	COMMENTS
N 6TH ST. (FAU 9677)		FOR INFORMATION ONLY							
STATION	LANE	#	FT X FT			FT	FT	FT	
51+63	LT TURN LANE	2	6	X	20	32	104	136	
51+63	THROUGH LANE	2	6	X	20	27	104	131	
51+60	RT TURN LANE	2	6	X	20	13	104	117	
48+91	NB DRIVING LANE	1	5	X	5	15	20	35	ADVANCE LOOP
<b>TOTALS</b>								419	

NOTE: THE DEPTH OF THE EXISTING DETECTOR LOOPS ARE UNKNOWN. THE PROPOSED QUANTITIES ARE INCLUDED IN THE EVENT THAT THE EXISTING DETECTOR LOOPS ARE DAMAGED DURING THE HMA SURFACE REMOVAL OPERATION.

MODEL: S00\_018.dwg FILE NAME: p:\road\pav\hwy\com\pav\DOT\Documents\DOT Office\Drawings\DOT Projects\9677\9677-PAV\9677-PAV-Schedules.dwg

USER NAME = Hunter Zeigler	DESIGNED -	REVISED -	<b>STATE OF ILLINOIS DEPARTMENT OF TRANSPORTATION</b>	<b>SCHEDULES</b>	SCALE:	SHEET 12 OF 20 SHEETS	STA.	TO STA.	FAU RTE. 9677	SECTION (13-1,27) RS-2	COUNTY JACKSON	TOTAL SHEETS 20	SHEET NO. 12	
PLOT SCALE = 0.18888833 / in.	CHECKED -	REVISED -			CONTRACT NO. 78929									
PLOT DATE = 7/28/2023	DATE -	REVISED -			ILLINOIS   FED. AID PROJECT									

MODEL: Intersections: resurfacing limits (8/24/17)  
 FILE NAME: P:\GIS\Projects\DOT\Office\Direct\9090\Project\78929\CADD\Drawings\DOT\_RESURFACING\_LIMITS\_Sht13.dwg

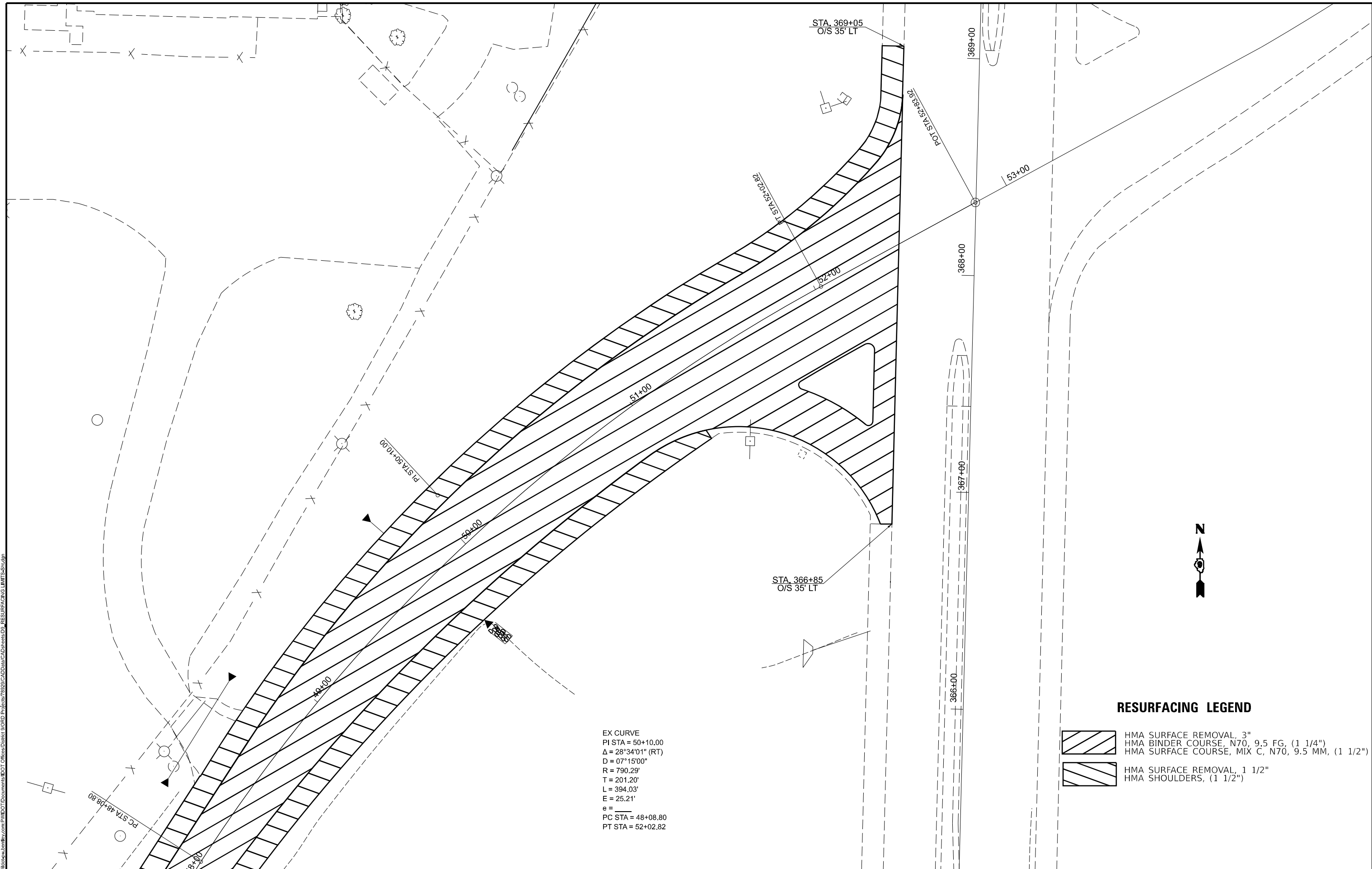

EX CURVE  
 PI STA = 50+10.00  
 $\Delta = 28^{\circ}34'01''$  (RT)  
 D =  $07^{\circ}15'00''$   
 R = 790.29'  
 T = 201.20'  
 L = 394.03'  
 E = 25.21'  
 e = \_\_\_\_\_  
 PC STA = 48+08.80  
 PT STA = 52+02.82

**RESURFACING LEGEND**

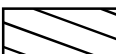
-  HMA SURFACE REMOVAL, 3"  
 HMA BINDER COURSE, N70, 9.5 FG, (1 1/4")  
 HMA SURFACE COURSE, MIX C, N70, 9.5 MM, (1 1/2")
-  HMA SURFACE REMOVAL, 1 1/2"  
 HMA SHOULDERS, (1 1/2")

USER NAME = Hunter.Zelger	DESIGNED -	REVISED -
PLOT SCALE = 0.16666633' / in.	DRAWN -	REVISED -
PLOT DATE = 7/28/2023	CHECKED -	REVISED -
	DATE -	REVISED -

**STATE OF ILLINOIS  
 DEPARTMENT OF TRANSPORTATION**

**RESURFACING LIMITS AT THE INTERSECTION  
 OF N 6TH ST AND IL 13/127**

SCALE: SHEET 13 OF 20 SHEETS STA. TO STA.

F.A.U. RTE.	SECTION	COUNTY	TOTAL SHEETS	SHEET NO.
9677	(13-1,27) RS-2	JACKSON	20	13
CONTRACT NO. 78929				
ILLINOIS FED. AID PROJECT				

PLAN	NO.
REVISION	DATE
BY	DATE
NO.	DATE
NO.	DATE
NO.	DATE
NO.	DATE
NO.	DATE
NO.	DATE
NO.	DATE
NO.	DATE

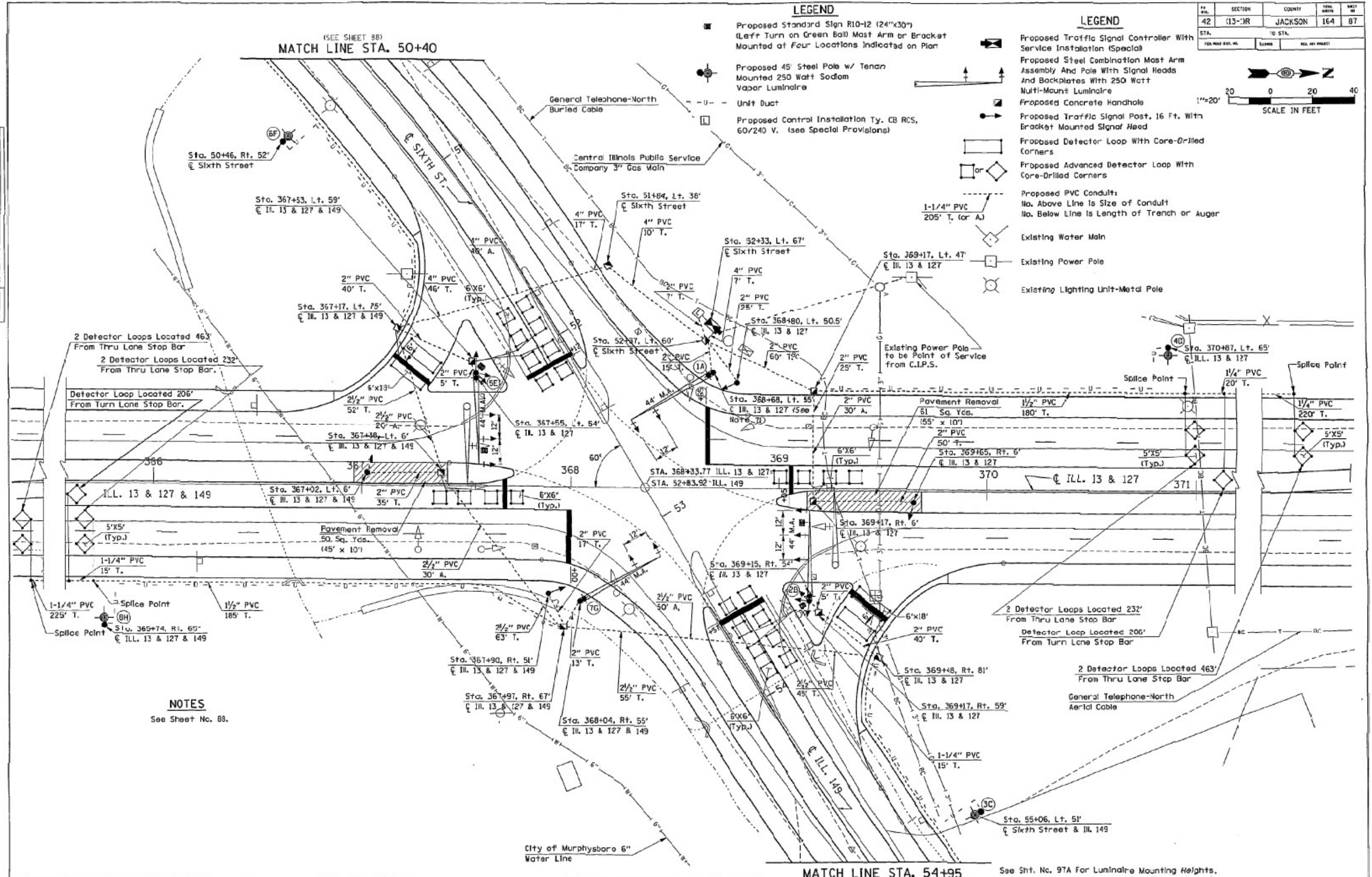

**LEGEND**

- Proposed Standard Sign R10-12 (24"x30") (Left Turn on Green Ball) Mast Arm or Bracket Mounted at Four Locations Indicated on Plan
- Proposed 45' Steel Pole w/ Tenon Mounted 250 Watt Sodium Vapor Luminaire
- - - Unit Duct
- Proposed Control Installation Ty. CB RCS, 60/240 V. (See Special Provisions)

**LEGEND**

- ⊠ Proposed Traffic Signal Controller With Service Installation (Special)
- ⊠ Proposed Steel Combination Mast Arm Assembly And Pole With Signal Heads And Backplates With 250 Watt Multi-Mount Luminaire
- ⊠ Proposed Concrete Handhole
- ⊠ Proposed Traffic Signal Post, 16 Ft. With Bracket Mounted Signal Head
- ⊠ Proposed Detector Loop With Core-Drilled Corners
- ⊠ Proposed Advanced Detector Loop With Core-Drilled Corners
- ⊠ Proposed PVC Conduit: No. Above Line Is Size of Conduit No. Below Line Is Length of Trench or Auger
- ⊠ Existing Water Main
- ⊠ Existing Power Pole
- ⊠ Existing Lighting Unit-Metal Pole

F.A.U. NO.	SECTION	COUNTY	TOTAL SHEETS	SHEET NO.
42	(13-1)R	JACKSON	164	87
STA.	TO STA.			
FED. AID PROJ. NO.		ROUTE	MILEAGE PROJECT	

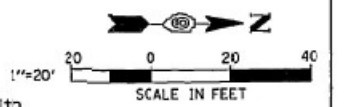

**NOTES**  
See Sheet No. 88.

Date: 11/15/2013 10:55:45 AM  
 User: Hunter.Zeigler  
 Plot Scale: 1/8" = 1'-0"  
 Plot Date: 7/28/2013

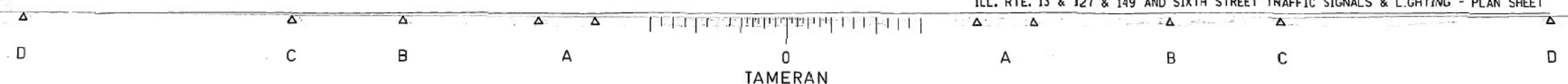

MATCH LINE STA. 54+95  
ILL. RTE. 13 & 127 & 149 AND SIXTH STREET TRAFFIC SIGNALS & LIGHTING - PLAN SHEET

USER NAME = Hunter.Zeigler	DESIGNED -	REVISED -
	DRAWN -	REVISED -
PLOT SCALE = 0.16666633 / in.	CHECKED -	REVISED -
PLOT DATE = 7/28/2013	DATE -	REVISED -

**STATE OF ILLINOIS  
DEPARTMENT OF TRANSPORTATION**

**EXISTING DETECTOR LOOP LOCATIONS  
(FOR INFORMATIONAL PURPOSES ONLY)**

SCALE: SHEET 14 OF 20 SHEETS STA. TO STA.

F.A.U. RTE.	SECTION	COUNTY	TOTAL SHEETS	SHEET NO.
9677	(13-127) RS-2	JACKSON	20	14
				CONTRACT NO. 78929
				ILLINOIS FED. AID PROJECT

MODEL: E:\Detector Loop Location 1 14 13.dwg  
 FILE NAME: P:\GIS\Projects\DOT\Office\DOT\Projects\78929\CADD\DOT\CADD\78929-Sign\DOT.dwg

MODEL: E:\Detector Loops 2 of 2 (Sheet)  
FILE NAME: I:\GIS\Projects\ROAD\Documents\DOT\Office\Sheet\I-90RD\Project\78929\CAD\Drawings\02-78929-Sheet\02-78929-PLAN.dwg

PLAN	DATE
DESIGNED	
DRAWN	
CHECKED	
DATE	
NO.	

Run Date: 12/08/2023 15:55  
/usr/bin/perl /usr/share/perl/5.34.0/libnet-ssl-0.06.pl  
/usr/bin/perl /usr/share/perl/5.34.0/libnet-ssl-0.06.pl  
/usr/bin/perl /usr/share/perl/5.34.0/libnet-ssl-0.06.pl  
/usr/bin/perl /usr/share/perl/5.34.0/libnet-ssl-0.06.pl

- NOTES**
- Location of Existing C.I.P.S. Transformer Is Approximately 80' From Proposed Service Installation. All Cable, Conduit, and Necessary Hardware Required For New Power Hook-Up Shall be included In The Contract Unit Price For Service Installation (Special-1 Each).
  - All Materials Required to Establish Electrical Hook-Up Shall be as Shown on Cable Diagram and Detail Sht. No. 89 Deviations From Materials Shown May Occur if so Directed by Central Illinois Public Service Company.
  - Full-Actuated Contoller, Standard Sequence IV, 8 Phases, in Type IV Cabinet With Service Installation (Special 7a be Mounted On Side of Traffic Signal Controller Cabinet. Cabinet Shall be Set on Concrete Foundation, Type D - 3.5 Ln. Ft.
  - Lighting Control Installation Shall be Pedestal Mounted. Foundation and Color of Cabinet Shall be as Specified in Special Provisions. This Item as Described in The Special Provisions Shall be Paid For at The Contract Unit Price For Control Installation, Type CB RCS 60-240- 1 Each.
  - Detector Loops Which Are 6'x15' or Greater Shall Have 3 Turns of Loop Wire. The 5'x5' Advance Loops Shall Have 4 Turns of Loop Wire or as Recommended by The Manufacturer. For Detail of 6'x6' Loops, See Sht. No. 97. These Loops Shall be Installed as Indicated on Detail Except Loops Will not be Staggered.
  - Luminaire Tilt Angle Shall Be Determined by Manufacturer of Luminaire or as Directed by the Engineer. For Mounting Heights see Sht. 97A.
  - Proposed Radio Transceiver Antenna Installed at this Location.

**LEGEND**

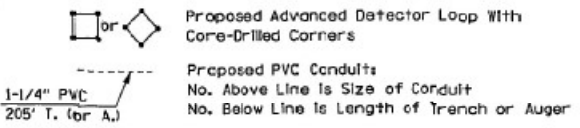

PL. NO.	SECTION	COUNTY	TOTAL SHEETS	SHEET NO.
42	(13-1)R	JACKSON	164	88
STA.	TO STA.			
FED. ROAD DIST. NO.	STATION	FED. AID PROJECT		

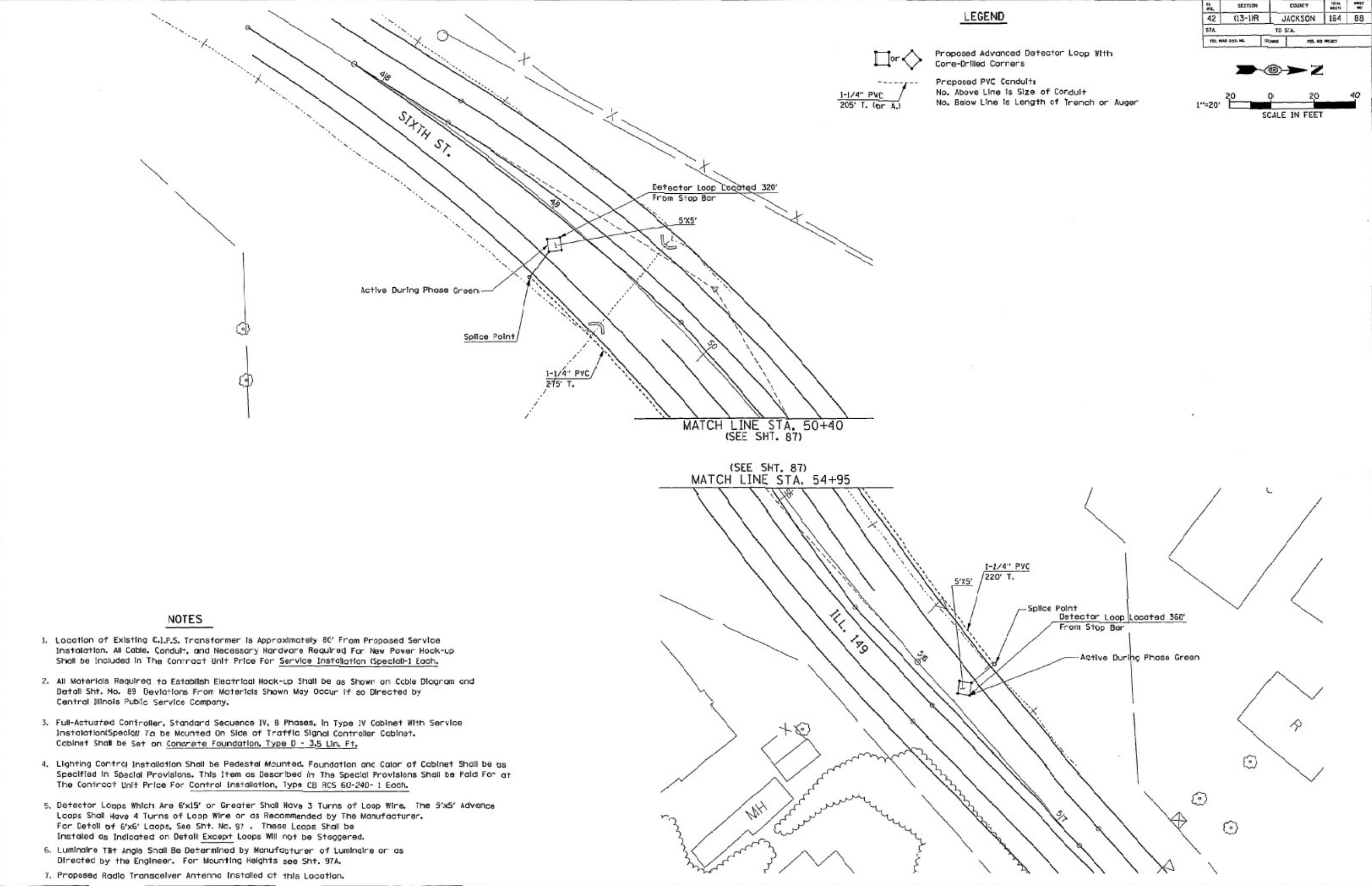

ILL. RTE. 13 & 127 & 149 AND SIXTH STREET TRAFFIC-SIGNALS LIGHTING - PLAN SHEET

USER NAME = Hunter.Zeigler	DESIGNED -	REVISED -	STATE OF ILLINOIS DEPARTMENT OF TRANSPORTATION		EXISTING DETECTOR LOOP LOCATIONS (FOR INFORMATIONAL PURPOSES ONLY)		F.A.U. RTE.	SECTION	COUNTY	TOTAL SHEETS	SHEET NO.
PLOT SCALE = 0.16666833 / in.	DRAWN -	REVISED -	SCALE:		SHEET 15 OF 20 SHEETS STA. TO STA.		9677	(13-1,27) RS-2	JACKSON	20	15
PLOT DATE = 7/28/2023	CHECKED -	REVISED -	ILLINOIS				CONTRACT NO. 78929				
DATE -	DATE -	REVISED -	FED. AID PROJECT								

**EX. HMA OR PCC SIDEROADS  
WITH BUTT JOINT**

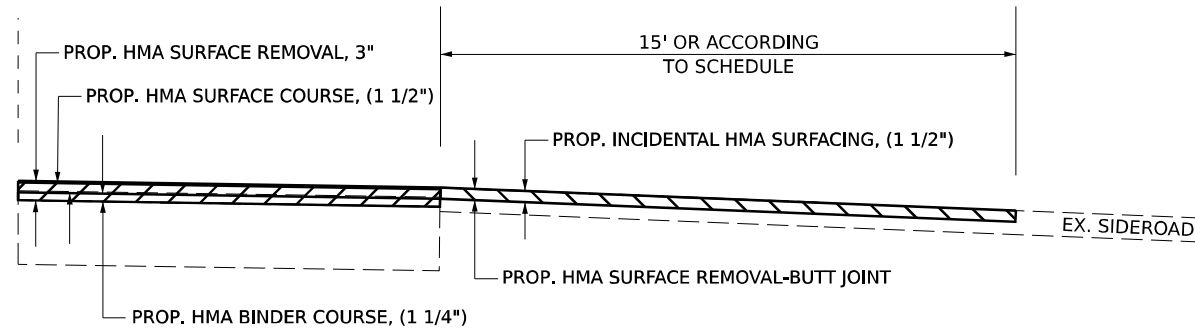

STA 13+08 TO STA 16+65

- NOTES:
1. IF THE EXISTING SUBBASE IS INADEQUATE, AS DETERMINED BY THE ENGINEER, THE SIDE ROAD SHALL BE CORED OUT AND AGGREGATE SUBBASE, TYPE B SHALL BE PLACED FOR BASE. THE COST OF CORING OUT THE SIDEROAD AND ANY AGGREGATE BASE COURSE SHALL BE PAID FOR AS SPECIFIED IN ART. 109.04 OF THE STANDARD SPECIFICATIONS FOR ROAD AND BRIDGE CONSTRUCTION, IF EXISTING SUBBASE IS DETERMINED TO BE ADEQUATE, THE PREPARATION OF THE BASE SHALL BE CONSTRUCTED ACCORDING TO ARTICLE 406.09
  2. VARIABLE SHAPING IS INCLUDED IN THE COST OF INCIDENTAL HOT-MIX ASPHALT SURFACE COURSE.

**EX. HMA OR PCC SIDEROADS  
WITH BUTT JOINT**

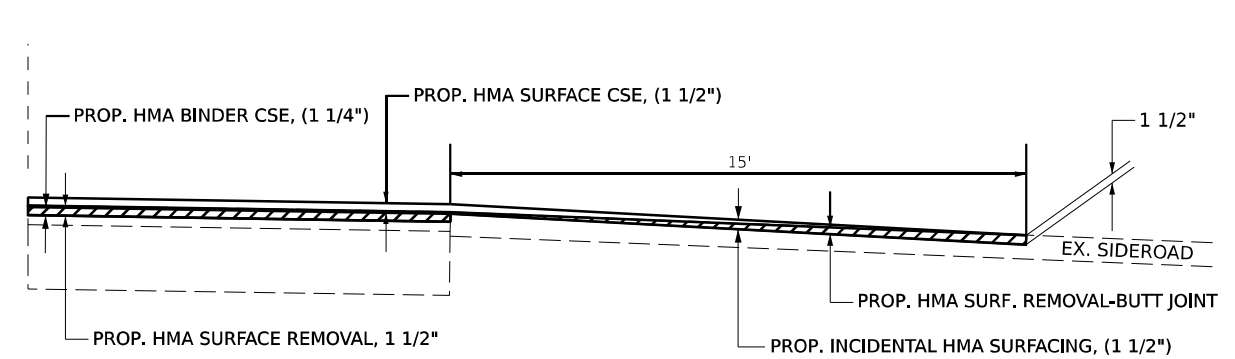

STA 16+65 TO STA 42+01

- NOTES:
1. IF THE EXISTING SUBBASE IS INADEQUATE, AS DETERMINED BY THE ENGINEER, THE SIDE ROAD SHALL BE CORED OUT AND AGGREGATE SUBBASE, TYPE B SHALL BE PLACED FOR BASE. THE COST OF CORING OUT THE SIDEROAD AND ANY AGGREGATE BASE COURSE SHALL BE PAID FOR AS SPECIFIED IN ART. 109.04 OF THE STANDARD SPECIFICATIONS FOR ROAD AND BRIDGE CONSTRUCTION, IF EXISTING SUBBASE IS DETERMINED TO BE ADEQUATE, THE PREPARATION OF THE BASE SHALL BE CONSTRUCTED ACCORDING TO ARTICLE 406.09
  2. VARIABLE SHAPING IS INCLUDED IN THE COST OF INCIDENTAL HOT-MIX ASPHALT SURFACE COURSE.

**EX. HMA OR PCC SIDEROADS  
WITH BUTT JOINT**

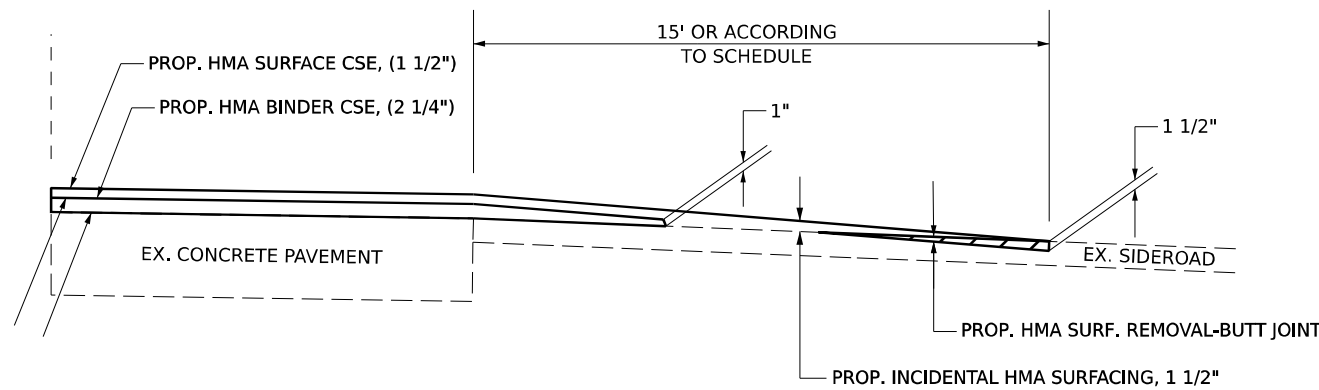

STA 42+01 TO STA 47+56

- NOTES:
1. IF THE EXISTING SUBBASE IS INADEQUATE, AS DETERMINED BY THE ENGINEER, THE SIDE ROAD SHALL BE CORED OUT AND AGGREGATE SUBBASE, TYPE B SHALL BE PLACED FOR BASE. THE COST OF CORING OUT THE SIDEROAD AND ANY AGGREGATE BASE COURSE SHALL BE PAID FOR AS SPECIFIED IN ART. 109.04 OF THE STANDARD SPECIFICATIONS FOR ROAD AND BRIDGE CONSTRUCTION, IF EXISTING SUBBASE IS DETERMINED TO BE ADEQUATE, THE PREPARATION OF THE BASE SHALL BE CONSTRUCTED ACCORDING TO ARTICLE 406.09
  2. VARIABLE SHAPING IS INCLUDED IN THE COST OF INCIDENTAL HOT-MIX ASPHALT SURFACE COURSE.

**SIDEROAD, ENTRANCE,  
& AGG. WEDGE SHOULDER DETAIL**

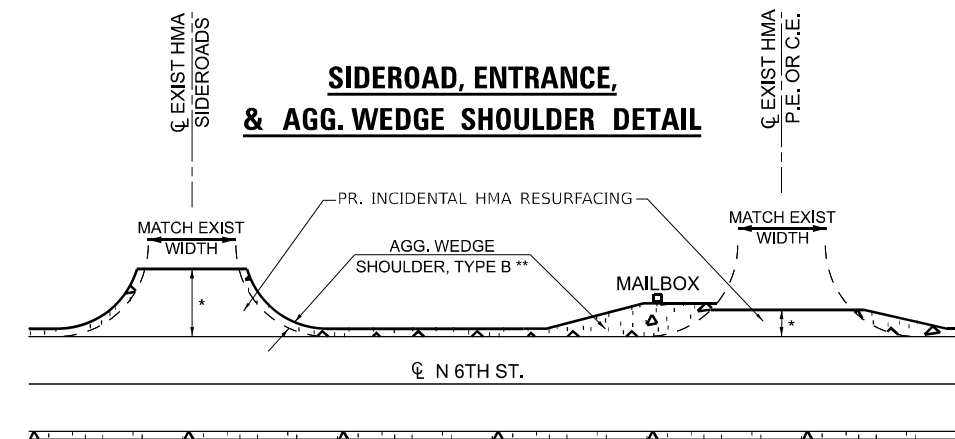

- \* SEE SIDEROAD AND ENTRANCE SCHEDULES FOR LENGTH  
\*\* SEE STANDARD 406201-01 FOR MAILBOX TURNOUTS

STA 16+65 TO 47+56

- NOTES:
1. IF THE EXISTING SUBBASE IS INADEQUATE, AS DETERMINED BY THE ENGINEER, THE SIDE ROAD SHALL BE CORED OUT AND AGGREGATE SUBBASE, TYPE B SHALL BE PLACED FOR BASE. THE COST OF CORING OUT THE SIDEROAD AND ANY AGGREGATE BASE COURSE SHALL BE PAID FOR AS SPECIFIED IN ART. 109.04 OF THE STANDARD SPECIFICATIONS FOR ROAD AND BRIDGE CONSTRUCTION, IF EXISTING SUBBASE IS DETERMINED TO BE ADEQUATE, THE PREPARATION OF THE BASE SHALL BE CONSTRUCTED ACCORDING TO ARTICLE 406.09
  2. VARIABLE SHAPING IS INCLUDED IN THE COST OF INCIDENTAL HOT-MIX ASPHALT SURFACE COURSE.

MODEL: SIDEROAD DETAIL.dwg (Sheet)  
FILE NAME: P:\GIS\Projects\78929\CADD\Drawings\DOT\Office\Drawings\78929\CADD\Drawings\78929-SHW-02.dwg

USER NAME = Hunter.Zeigler	DESIGNED -	REVISED -
PLOT SCALE = 0.16666633' / in.	DRAWN -	REVISED -
PLOT DATE = 7/28/2023	CHECKED -	REVISED -
	DATE -	REVISED -

**STATE OF ILLINOIS  
DEPARTMENT OF TRANSPORTATION**

**SIDEROAD DETAIL**

SCALE: SHEET 16 OF 20 SHEETS STA. TO STA.

F.A.U. RTE.	SECTION	COUNTY	TOTAL SHEETS	SHEET NO.
9677	(13-1,27) RS-2	JACKSON	20	16
CONTRACT NO. 78929				
ILLINOIS FED. AID PROJECT				



**HMA, PCC, OR OIL & CHIP  
PRIVATE OR COMMERCIAL ENTRANCE**

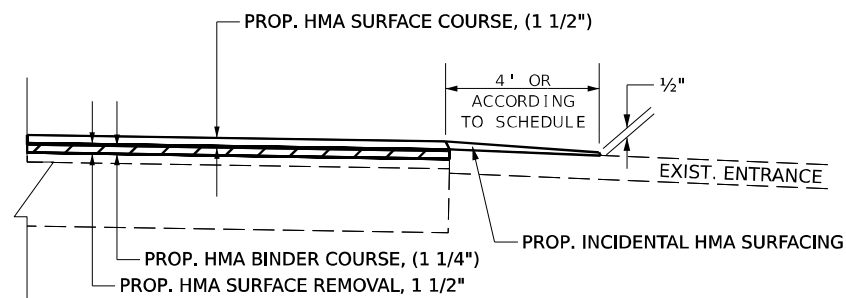

STA 16+65 TO STA 42+01

**AGG. PRIVATE  
OR COMMERCIAL ENTRANCE**

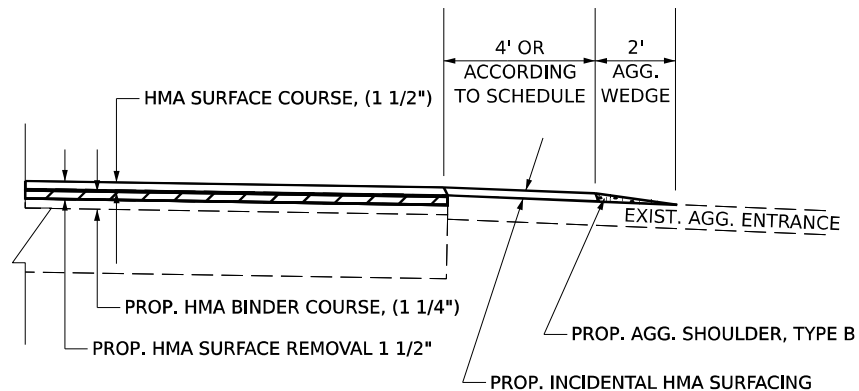

STA 16+65 TO STA 42+01

**HMA, PCC, OR OIL & CHIP  
PRIVATE OR COMMERCIAL ENTRANCE WITH BUTT JOINT**

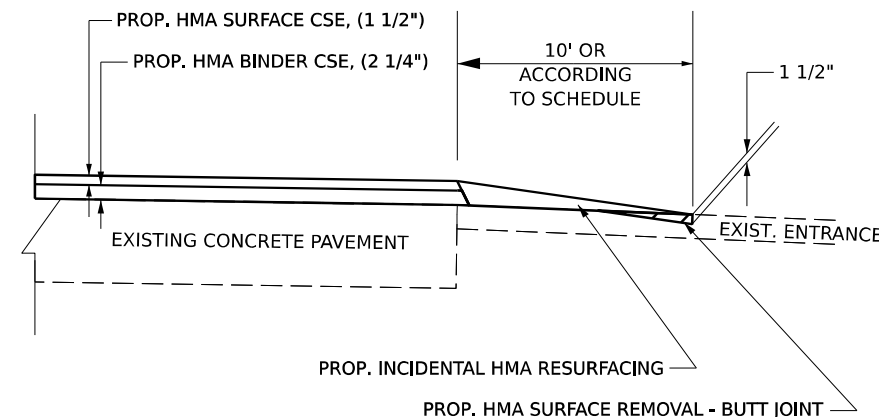

STA 42+01 TO STA 47+56

**AGG. COMMERCIAL ENTRANCE**

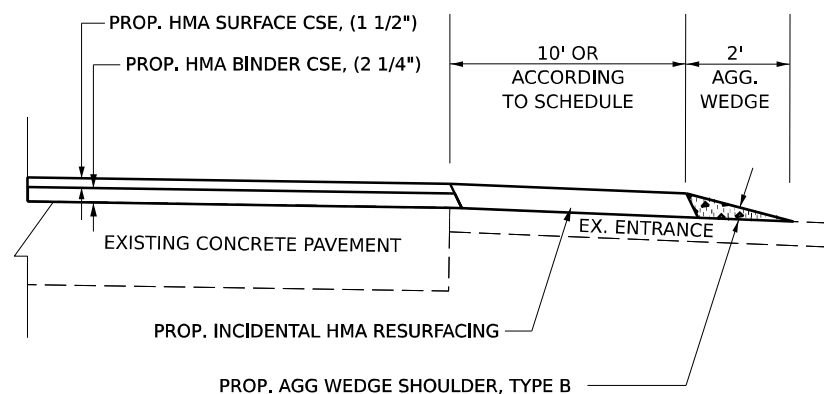

STA 42+01 TO STA 47+56

**HMA, PCC, OR OIL & CHIP  
PRIVATE OR COMMERCIAL ENTRANCE**

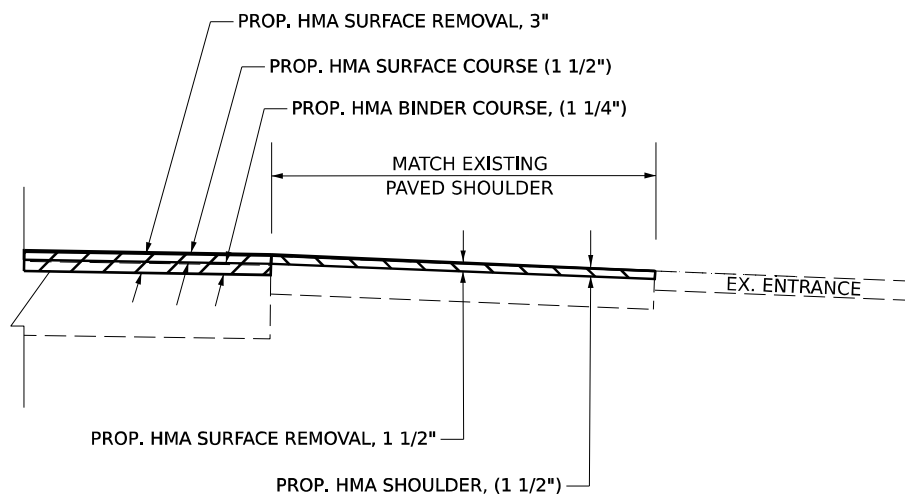

STA 47+56 TO STA 52+43

THIS SPACE WAS INTENTIONALLY LEFT BLANK.

MODEL: Entrance Detail-2 (Sheet)  
FILE NAME: P:\GIS\Projects\DOT\Office\District 9\ORD Project\78929\CADD\Drawings\DOT\78929-SHW\4-Detail.dgn

USER NAME = Hunter.Zeigler	DESIGNED -	REVISED -
PLOT SCALE = 0.16666633' / in.	DRAWN -	REVISED -
PLOT DATE = 7/28/2023	CHECKED -	REVISED -
	DATE -	REVISED -

**STATE OF ILLINOIS  
DEPARTMENT OF TRANSPORTATION**

**ENTRANCE DETAIL**

SCALE: SHEET 17 OF 20 SHEETS STA. TO STA.

F.A.U. RTE.	SECTION	COUNTY	TOTAL SHEETS	SHEET NO.
9677	(13-1.27) RS-2	JACKSON	20	17
CONTRACT NO. 78929				
ILLINOIS FED. AID PROJECT				

**FAU 9677**  
**DETAIL FOR MILLING TRANSITION**

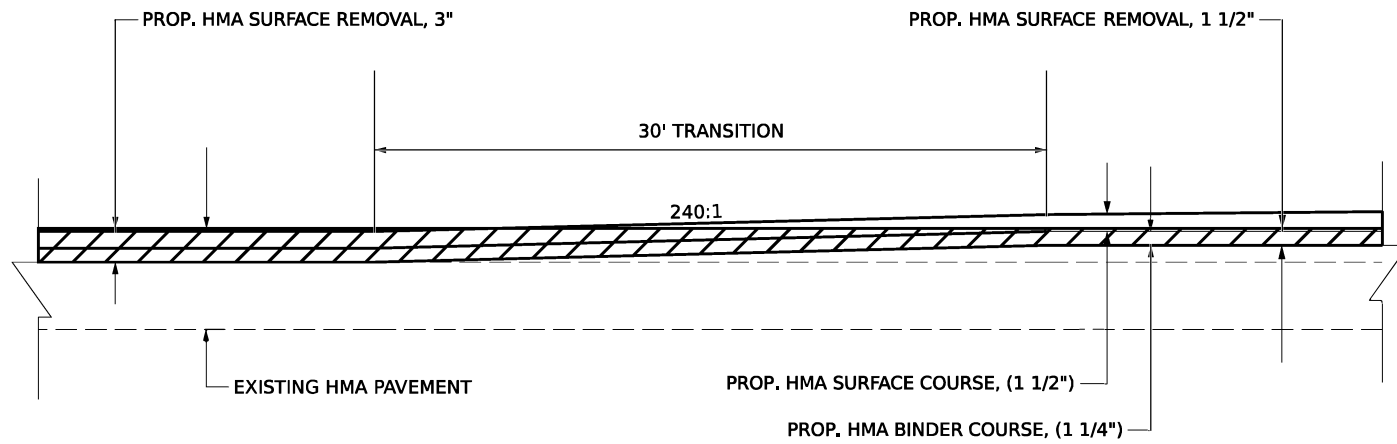

TO BE USED: STA 16+65 TO STA 16+95

\* THE VARIABLE THICKNESS HMA SURFACE REMOVAL FROM 16+65 TO 16+95 WILL BE INCLUDED IN THE COST OF HMA SURFACE REMOVAL 1 1/2"

**FAU 9677**  
**DETAIL FOR HMA AND MILLING TRANSITION**

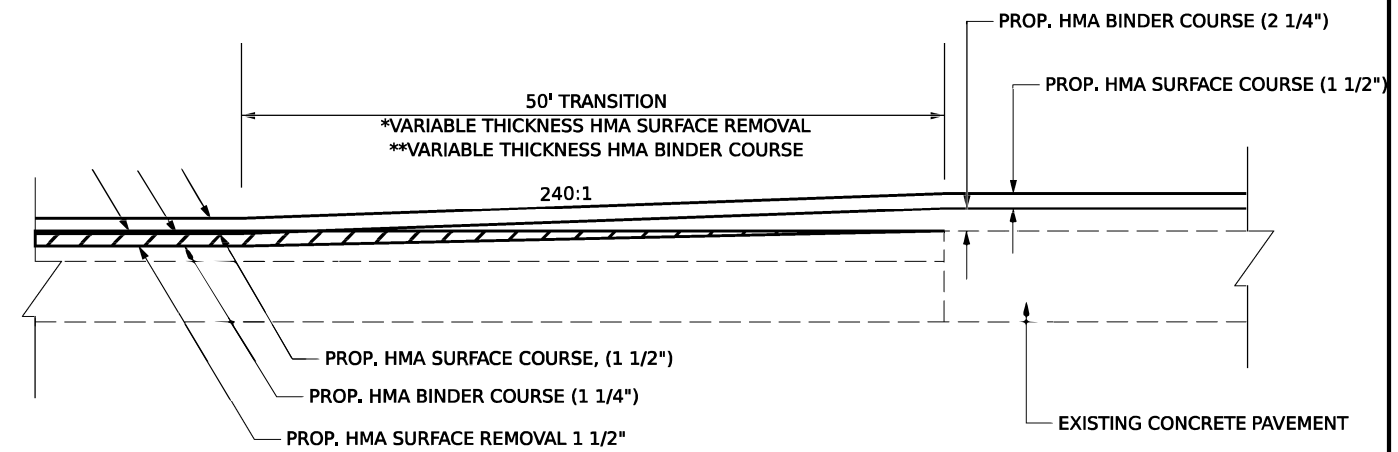

TO BE USED: STA 41+51 TO STA 42+01

\* THE VARIABLE THICKNESS HMA SURFACE REMOVAL FROM 41+51 TO 42+01 WILL BE INCLUDED IN THE COST OF HMA SURFACE REMOVAL 1 1/2"

\*\*THE VARIABLE THICKNESS OF HMA BINDER COURSE FROM 1 1/4" TO 2 1/4" WILL BE INCLUDED IN THE COST OF HMA BINDER COURSE 1 1/4"

**FAU 9677**  
**DETAIL FOR HMA TRANSITION**

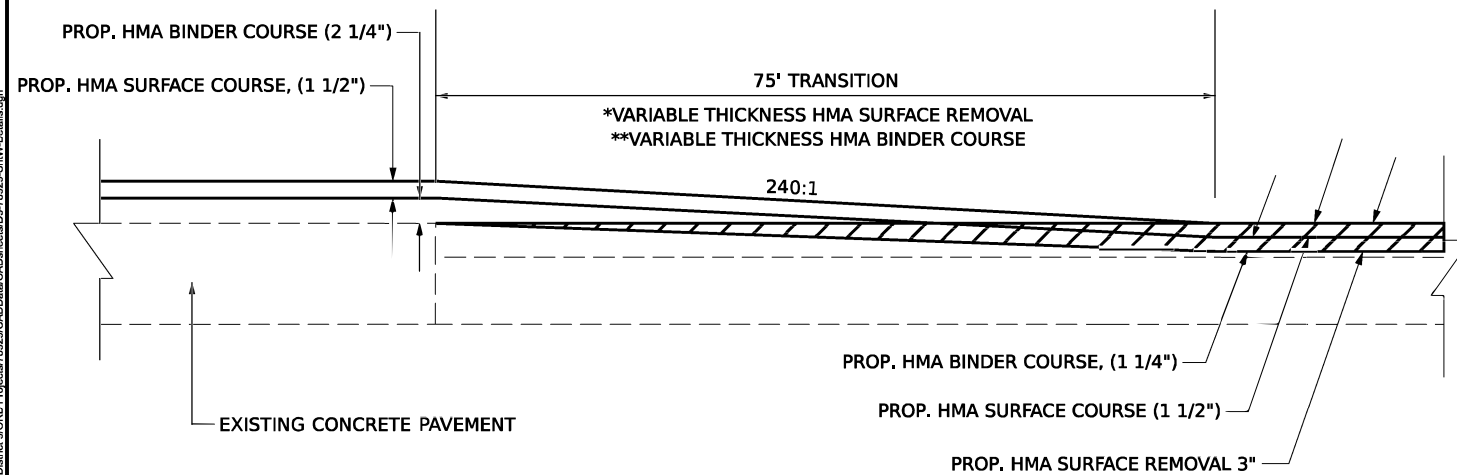

TO BE USED: STA 47+56 TO STA 48+31

\* THE VARIABLE THICKNESS HMA SURFACE REMOVAL FROM STA. 47+56 TO 48+31 WILL BE INCLUDED IN THE COST OF HMA SURFACE REMOVAL 3"

\*\*THE VARIABLE THICKNESS OF HMA BINDER COURSE FROM 1 1/4" TO 2 1/4" WILL BE INCLUDED IN THE COST OF HMA BINDER COURSE 1 1/4"

THIS SPACE WAS INTENTIONALLY LEFT BLANK.

REV. - MS

MODEL: HMA Transitions; Temp: Ramps and Slabs; Title: PLOT; Author: Hunter Zeigler; Date: 7/28/2023; Project: FAU 9677; Section: (13-1.27) RS-2; County: JACKSON; Contract: 78929; Sheet: 18 of 20

USER NAME = Hunter Zeigler	DESIGNED -	REVISED -
PLOT SCALE = 0.16666633' / in.	DRAWN -	REVISED -
PLOT DATE = 7/28/2023	CHECKED -	REVISED -
	DATE -	REVISED -

**STATE OF ILLINOIS**  
**DEPARTMENT OF TRANSPORTATION**

**TRANSITIONS**

SCALE: SHEET 18 OF 20 SHEETS STA. TO STA.

F.A.U. RTE.	SECTION	COUNTY	TOTAL SHEETS	SHEET NO.
9677	(13-1.27) RS-2	JACKSON	20	18
CONTRACT NO. 78929				
ILLINOIS FED. AID PROJECT				



## ILLINOIS STANDARD ROUGH GROOVED SURFACE SIGN

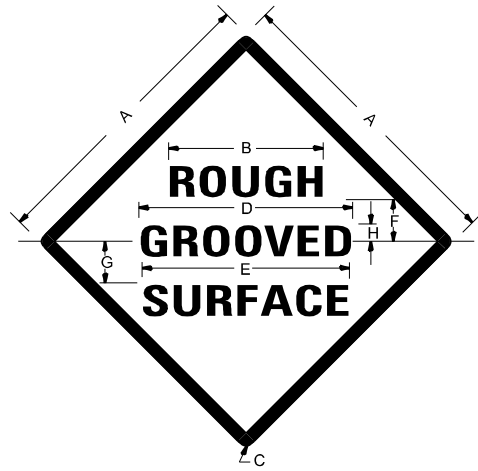

### COLORS

LEGEND AND BORDER- BLACK NON-REFLECTORIZED  
BACKGROUND- ORANGE REFLECTORIZED

SIGN SIZE	DIMENSIONS							
	A	B	C	D	E	F	G	H
48X48	48.0	24.1	3.0	34.0	33.0	6.0	13.0	3.5

SIGN SIZE	SERIES LINES			MAR-GIN	BOR-DER	BLANK STD.
	1	2	3			
48X48	7C	7C	7C	0.8	1.2	B4-48D

ALL DIMENSIONS IN INCHES

### NOTES

PRIOR TO ALLOWING TRAFFIC ON ANY PORTION OF THE ROADWAY THAT HAS BEEN COLDMILLED, THE CONTRACTOR SHALL HAVE ERECTED "ROUGH GROOVED SURFACE" SIGNS THAT CONFORM TO THE ABOVE DETAILS. A MINIMUM OF ONE SIGN AT EACH END OF THE IMPROVEMENT WILL BE REQUIRED. THE CONTRACTOR SHALL MAINTAIN THE "ROUGH GROOVED SURFACE" SIGNS UNTIL THE COLDMILLED SURFACE IS COVERED WITH LEVELING BINDER OR SURFACE COURSE.

IF AT ANY TIME THE SIGNS ARE IN PLACE BUT NOT APPLICABLE, THEY SHALL BE TURNED FROM THE VIEW OF MOTORISTS OR COVERED AS DIRECTED BY THE ENGINEER.

THE COST OF FURNISHING, ERECTING, MAINTAINING, AND REMOVING THE REQUIRED SIGNS SHALL BE INCLUDED IN THE CONTRACT.

DRAWN	02-15-89
REVISED	03-27-08
REVISED	10-21-21
REVISED	05-27-22

STD. 9-23

## UNEVEN LANES SIGN W8-11 (48" X 48")

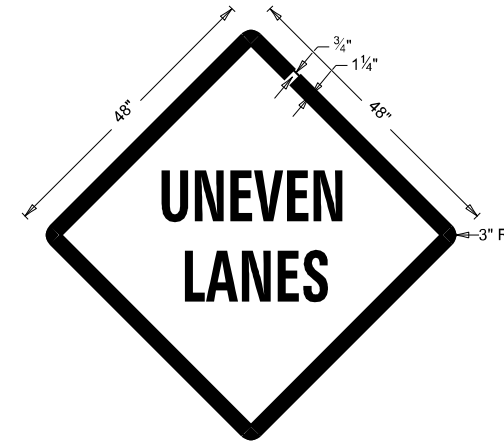

### COLORS:

LEGEND AND BORDER - BLACK NON-REFLECTORIZED  
BACKGROUND - ORANGE REFLECTORIZED

NOTE: PRIOR TO ALLOWING TRAFFIC ON ANY PORTION OF THE ROADWAY THAT HAS BEEN COLDMILLED OR BEFORE RESURFACING OPERATIONS BEGIN, THE CONTRACTOR SHALL HAVE ERECTED "UNEVEN PAVEMENT" SIGNS THAT CONFORM TO THE ABOVE DETAILS. A MINIMUM OF ONE SIGN AT EACH END OF THE IMPROVEMENT WILL BE REQUIRED. THE CONTRACTOR SHALL MAINTAIN THE "UNEVEN PAVEMENT" SIGNS UNTIL THE RESURFACING OPERATIONS ARE COMPLETED.

IF AT ANY TIME THE SIGNS ARE IN PLACE BUT NOT APPLICABLE, THEY SHALL BE TURNED FROM THE VIEW OF MOTORISTS OR COVERED AS DIRECTED BY THE ENGINEER.

THE COST OF FURNISHING, ERECTING, MAINTAINING, AND REMOVING THE REQUIRED SIGNS SHALL BE INCLUDED IN THE CONTRACT.

DRAWN	02-15-89
REVISED	05-08-08
REVISED	10-21-21
REVISED	05-27-22

STD. 9-24

## TEMPORARY HOT-MIX ASPHALT TRANSITIONS

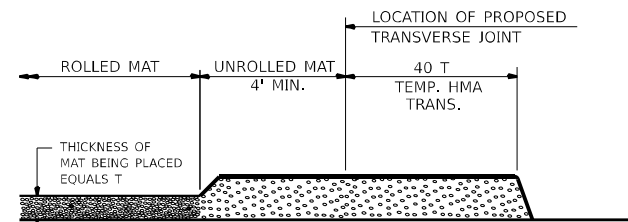

### STEP I

1. PLACE HOT-MIX ASPHALT MAT, LENGTH 40 TIMES THE THICKNESS OF THE MAT BEING PLACED PAST THE PROPOSED TRANSVERSE JOINT LOCATION USING NORMAL OPERATING PROCEDURES.
2. EXTREME CARE SHOULD BE TAKEN TO MAINTAIN ENOUGH MATERIAL IN FRONT OF THE SCREED TO MAINTAIN REQUIRED PAVING DEPTH.

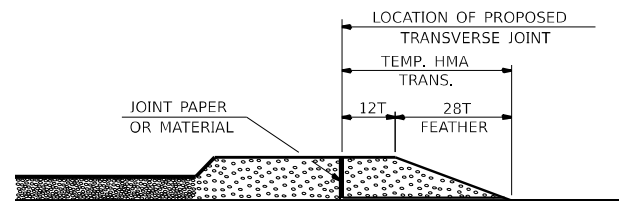

### STEP III

1. JOINT PAPER OR OTHER PRESELECTED JOINT MATERIAL IS THEN PLACED IN THE CLEARED AREA AND THE EXCESS ASPHALT USED TO HAND FORM A TRANSITION TO THE DIMENSIONS SHOWN ABOVE.
2. NOTE THAT IN CONSTRUCTING THE TRANSITION, THE MAT DEPTH IS CONTINUED AS PART OF THE TRANSITION BEFORE FORMING THE FEATHER.

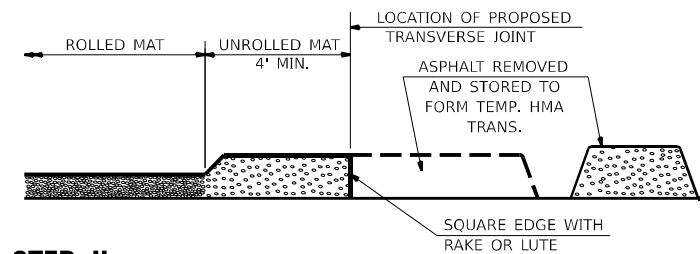

### STEP II

1. MOVE THE PAVER OUT OF THE WAY AND REMOVE THE ASPHALT FROM THE AREA OF THE PROPOSED TEMPORARY HOT-MIX ASPHALT TRANSITION.
2. SQUARE UP THE END OF THE MAT WITH A RAKE OR LUTE.
3. NOTE THAT THE MAT WITHIN 4' OF THE END OF JOINT IS NOT TO BE ROLLED AT THIS TIME.

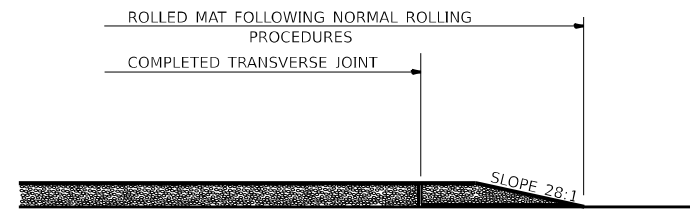

### STEP IV

1. COMPLETE TEMPORARY TRANSITION BY ROLLING.
2. TO RESUME PAVING, AT THE JOINT, REMOVE TEMPORARY TRANSITION AND DISPOSE OF THE MATERIAL ACCORDING TO ART. 202.03 OF THE STD. SPECS. (COST INCLUDED IN THE CONTRACT).
3. CONSTRUCTING THE TEMPORARY TRANSITIONS WILL NOT BE PAID FOR SEPARATELY IN ACCORDANCE WITH ARTICLE 406.14 OF THE STANDARD SPECIFICATIONS.

STD. 9-26

REVISIONS	
REDRAWN	2-15-89
REVISED	8-16-94
REVISED	01-09-07
REVISED	05-8-08
REVISED	05-16-13
REVISED	10-21-21

## DETAIL OF DETECTOR LOOPS

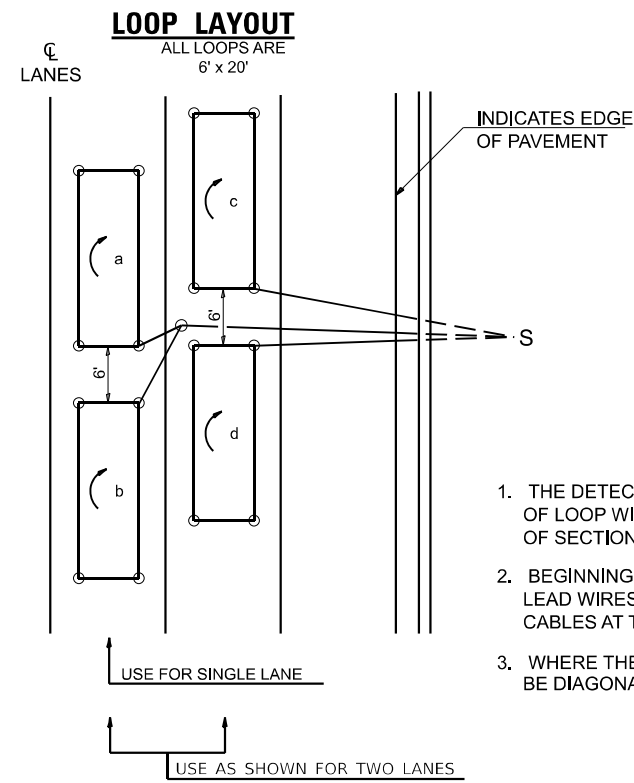

### LOOP LEGEND

- ⤵ CLOCKWISE ROTATION FOR LOOP WIRES
- S INDICATES SPLICE POINT FOR DETECTOR LOOP LEAD
- INDICATES 2" CORE-DRILL

### NOTES

1. THE DETECTOR LOOPS SHALL BE TYPE I. EACH DETECTOR LOOP SHALL HAVE 3 TURNS OF LOOP WIRE AND BE INSTALLED IN ACCORDANCE WITH THE APPLICABLE PORTIONS OF SECTION 886.
2. BEGINNING LEAD WIRES SHALL BE CONNECTED TO THE BLACK LEAD AND THE ENDING LEAD WIRES SHALL BE CONNECTED TO THE WHITE LEAD OF THE TWIN TWISTED FEED CABLES AT THE SPLICE POINT.
3. WHERE THE LOOPS ARE INSTALLED PRIOR TO RESURFACING, THE LOOP CORNERS SHALL BE DIAGONALLY CUT.

DRAWN	05-13-02
REVISED	03-26-08
REVISED	10-21-21
REVISED	05-03-22

STD. 9-05

MODEL: District Standards (Sheet)  
FILE NAME: P:\Bids\2022\Standard\DOT\Office\District\BORD Project\78929\CAD\Drawings\DOT-886-Standard

USER NAME = Hunter.Zeigler	DESIGNED -	REVISED -
PLOT SCALE = 0.16666633 / in.	DRAWN -	REVISED -
PLOT DATE = 7/28/2023	CHECKED -	REVISED -
	DATE -	REVISED -

**STATE OF ILLINOIS  
DEPARTMENT OF TRANSPORTATION**

**DISTRICT STANDARDS**

SCALE: SHEET 20 OF 20 SHEETS STA. TO STA.

F.A.U. RTE.	SECTION	COUNTY	TOTAL SHEETS	SHEET NO.
9677	(13-1,27) RS-2	JACKSON	20	20
CONTRACT NO. 78929				
ILLINOIS   FED. AID PROJECT				