

ALL DIMENSIONS IN METERS EXCEPT PAVEMENT ITEMS AND UNLESS NOTED OTHERWISE

F.A.I. RTE.	SECTION	COUNTY	TOTAL SHEETS	SHEET NO.
80/94	2626.2-R-2	COOK/LAKE	1207	102
STA.		TO STA.		
FED. ROAD DIST. NO.		ILLINOIS FED. AID PROJECT		
CONTRACT NO. 62114		INDOT DES. NO. 0100987		

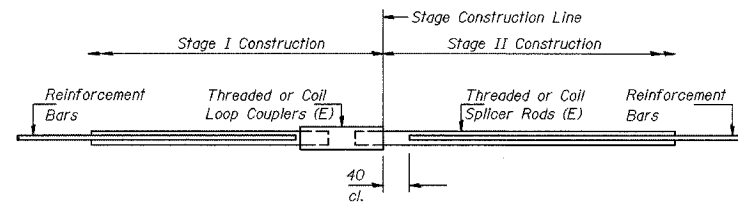

BAR SPLICER ASSEMBLY DETAIL FOR STAGED LUG SYSTEM Bars "b"

Bar Size	No. Assemblies Required	Location
#15	18 *	STA 6+860 WB
#15	18	STA 6+973 EB
#15	18	STA 7+915 EB

* STAGE II CONSTRUCTION ONLY
BAR SPLICERS PROVIDED BY
CONTRACT 62113

The diameter of this part is the same as the diameter of the bar spliced.

ROLLED THREAD DOWEL BAR



Wire Connector



BAR SPLICER ASSEMBLY ALTERNATIVES

** Heavy Hex Nuts conforming to ASTM A 563M, Grade C, D or DH may be used.

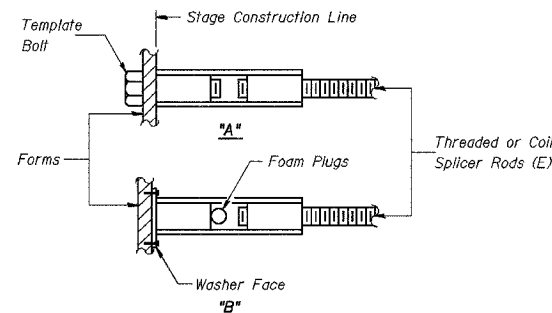

INSTALLATION AND SETTING METHODS

"A" : Set bar splicer assembly by means of a template bolt.
"B" : Set bar splicer assembly by nailing to wood forms or cementing to steel forms.
(E) : Indicates epoxy coating.

NOTES

Bar splicer assemblies shall be of an approved type and shall develop in tension at least 125 percent of the yield strength of the lapped reinforcement bars. Splicer rods shall be of minimum 400 MPa yield strength, threaded or rolled full length. All reinforcement bars shall be lapped and tied to the splicer rods or dowel bars. Bar splicer assemblies shall be epoxy coated according to the requirements for reinforcement bars.

Other systems of similar design may be submitted to the Engineer for approval. Approval shall be based on certified test results from an approved testing laboratory that the proposed bar splicer assembly satisfies the following requirements:

- ① Minimum Capacity (Tension in kN) = $1.25 \times 10^{-3} \times f_y \times A_f$
- ② Minimum *Pull-out Strength (Tension in kN) = $1.25 \times 10^{-3} \times f_{s\text{allow}} \times A_f$

Where f_y = Yield strength of lapped reinforcement bars in MPa.

$f_{s\text{allow}}$ = Allowable tensile stress in lapped reinforcement bars in MPa (Service Load)

A_f = Tensile stress area of lapped reinforcement bars (mm^2).

* = 28 day concrete

BAR SPLICER ASSEMBLIES

Bar Size to be Spliced	Splicer Rod or Dowel Bar Length	Strength Requirements	
		Min. Capacity kN - tension	Min. Pull-Out Strength kN - tension
#15	610 mm	100	40

Bar splicer assemblies shall be installed at the lug locations as shown on the plan details for the staged lug systems.

When the second stage of the lug system is to be completed in a separate contract, the Contractor shall deliver the remainder of the bar splicer to the IDOT Bishop Ford Maintenance Yard (708) 331-4339 for storage.

The bars shall be enclosed in a water resistant wooden container of sufficient strength to withstand the anticipated handling of the bar splicers prior to reuse at a later date. The container shall be clearly stamped for the designated location of the bar splicer use.

Bar splicer assemblies shall be according to Section 508 of the Standard Specifications, except as noted. The furnishing and installation of bar splicer assemblies will be measured and paid for at the contract unit price each for "BAR SPLICERS, SPECIAL."
All dimensions are in millimeters (mm) except as noted.

BAR SPLICER ASSEMBLY DETAILS

ILLINOIS DEPARTMENT OF TRANSPORTATION
I-80/94/US 6
KINGERY-BORMAN EXPRESSWAY
BURNHAM ROAD TO US 41
**BAR SPLICER ASSEMBLY
DETAIL FOR
LUG SYSTEM Bars b**

SCALE NONE DRAWN BY ACE/CAD
DATE 07/05 CHECKED BY TAE



REVISIONS	
NAME	DATE