

ROUTE NO.	SECTION	COUNTY	SHEET	PROJECT	SHEET NO. S-44
F.A.L. 80/94	2626.2-R-1	LAKE COUNTY, INDIANA	1207	663	72 SHEETS
ILLINOIS DEPARTMENT OF TRANSPORTATION					
CONTRACT NO. 62114					INDOT DES. NO. 0100987

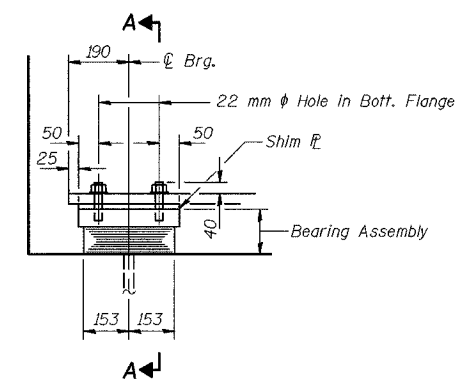

**ELEVATION AT ABUT.**

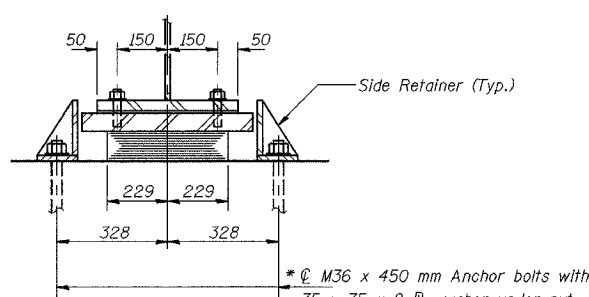

**SECTION A-A**

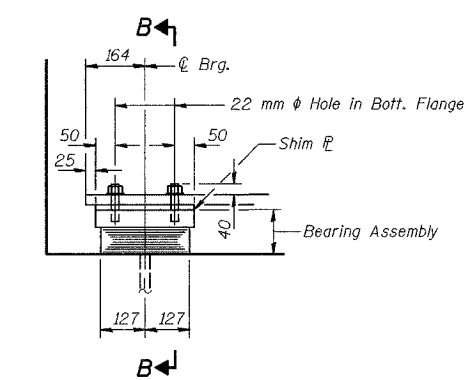

**ELEVATION AT ABUT.**

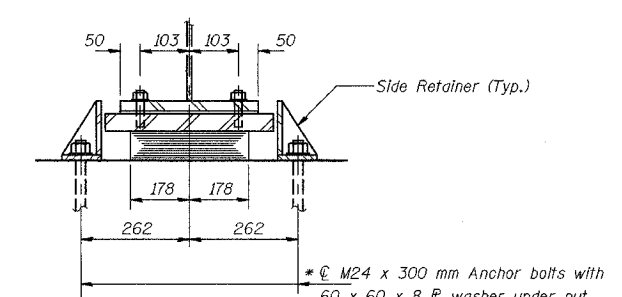

**SECTION B-B**

**TYPE I ELASTOMERIC WEST EXP. BRG. AT PIER 3 GIRDERS 15 - 28**

**TYPE I ELASTOMERIC EAST EXP. BRG. AT PIER 3**

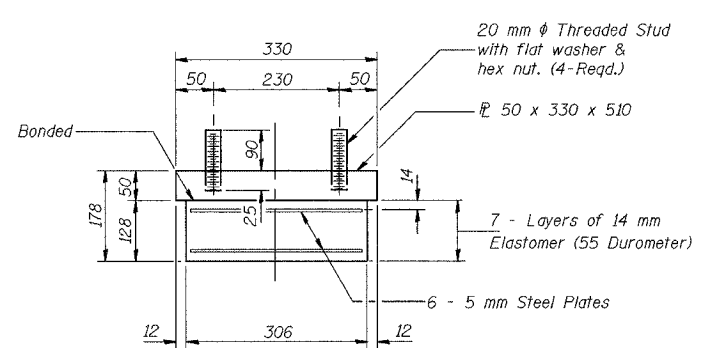

**BEARING ASSEMBLY**

Note: Shim plates shall not be placed under Bearing Assembly.

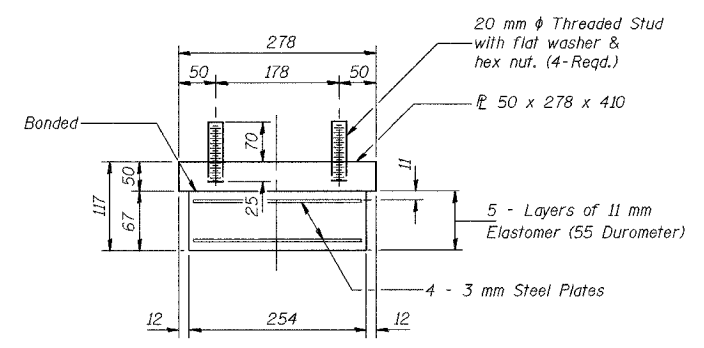

**BEARING ASSEMBLY**

Note: Shim plates shall not be placed under Bearing Assembly.

Notes: See Sheet S-47 for Anchor Bolt Installation. All dimensions are in millimeters (mm) except as noted.

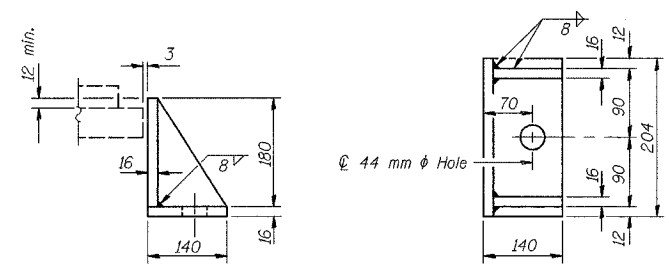

**SIDE RETAINER**

Equivalent rolled angle with stiffeners will be allowed in lieu of welded plates. Mass included with Structural Steel.

Note: The 3 mm TFE sheet shall be bonded directly to the top steel plate with a two-component, medium viscosity epoxy resin, conforming to the requirements of the Federal Specification MMM-A-134, Type I. The bond agent shall be applied on the full area of the contact surfaces.

Bonding of 3 mm TFE sheet during vulcanizing process will be permitted provided the process and method of adjusting assembly height is approved by the Engineer.

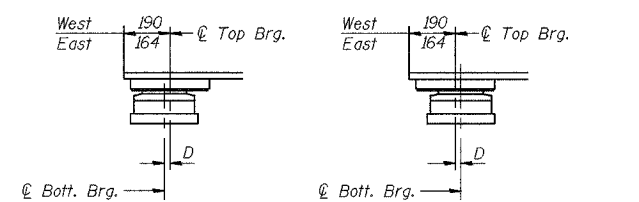

**SETTING ANCHOR BOLTS AT EXP. BRG.**

D = 1 mm per each 10 m of expansion for every 8 °C temp. change from the normal temp. of 10 °C.

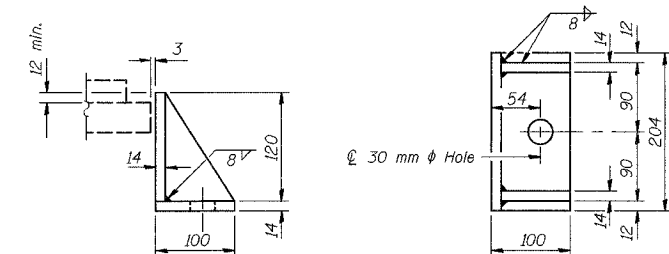

**SIDE RETAINER**

Equivalent rolled angle with stiffeners will be allowed in lieu of welded plates. Mass included with Structural Steel.

**BILL OF MATERIAL**

Item	Unit	Total
* Furnishing Elastomeric Bearing Assembly, Type I	Each	42

DESIGNED	BHS
CHECKED	KFA
DRAWN	MJB
CHECKED	GSP

**\* FURNISHING BEARINGS NOT INCLUDED IN THIS CONTRACT**

ILLINOIS DEPARTMENT OF TRANSPORTATION  
 F.A.I. ROUTE 80/94 (BORMAN EXPRESSWAY)  
 OVER LITTLE CALUMET RIVER & N.I.C.T.D. R.O.W.

**BEARING DETAILS (3 OF 5)**  
**SECTION 2626.2-R-1**  
**LAKE COUNTY, INDIANA**  
**STATION 8+470.000**  
**STRUCTURE NO. I-80-1-8460 (EB & WB)**  
 DATE 07/05 (016-1003 & 016-1004)

**AMERICAN**  
 CONSULTING ENGINEERS