

F.A.P. RTE.	SECTION	COUNTY	TOTAL SHEETS	SHEET NO.
303	I29K	WINNEBAGO	585	173

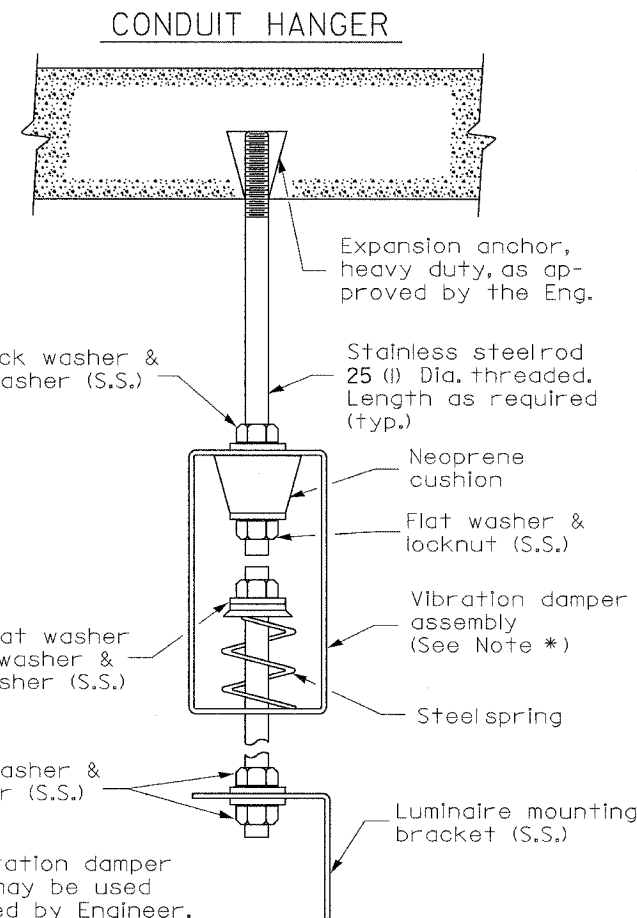
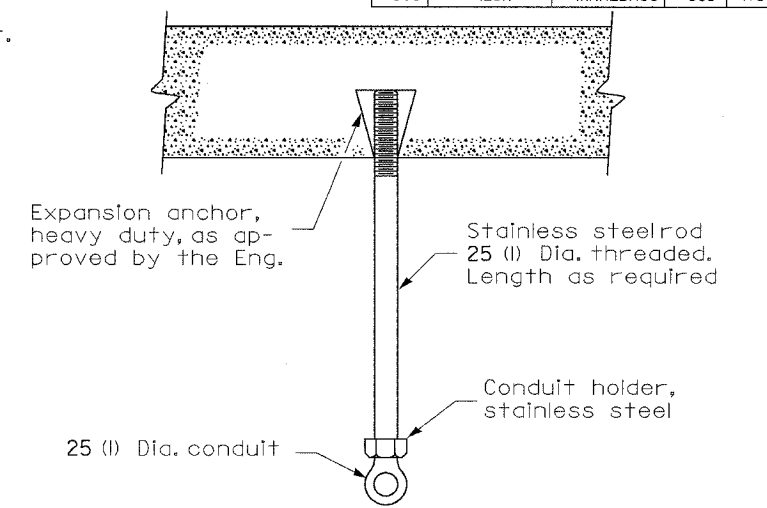
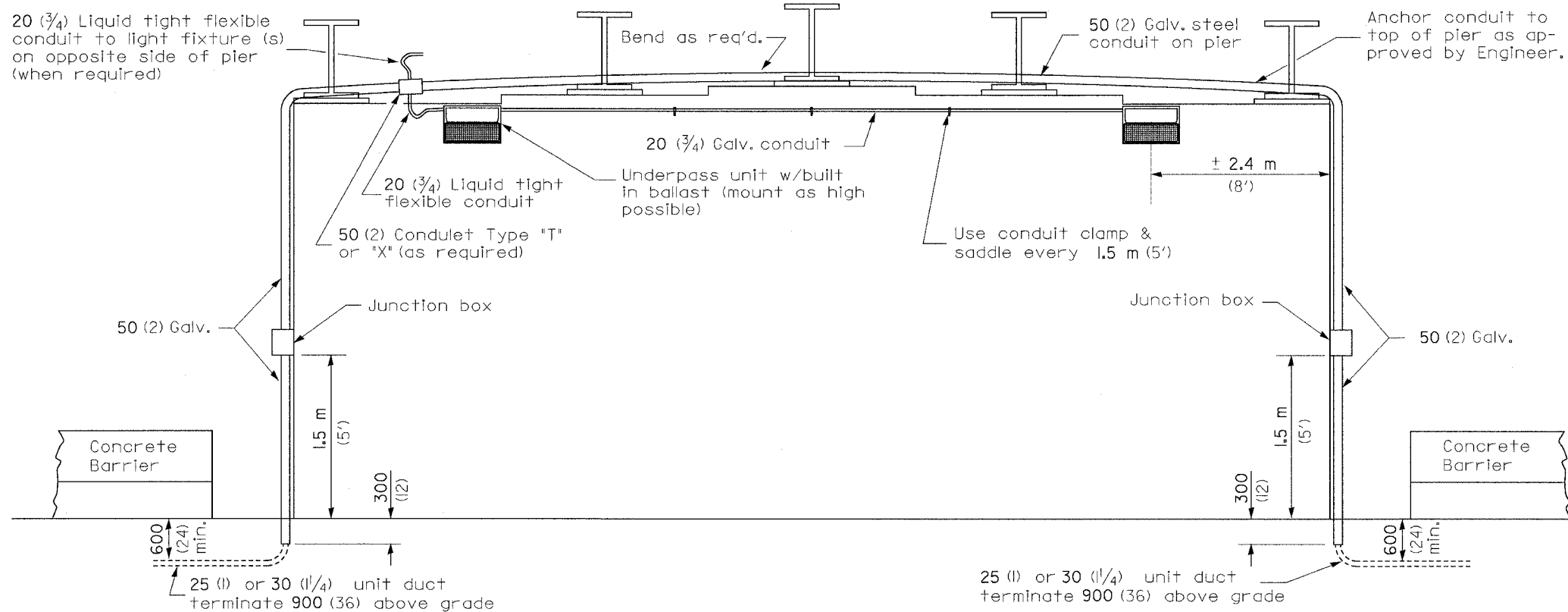

* Note:
Other vibration damper assembly may be used if approved by Engineer.

LUMINAIRE HANGER ASSEMBLY DETAIL A

All dimensions are in millimeters (inches) unless otherwise shown.

UNDERPASS LIGHTING
(Mounted on Face Pier)

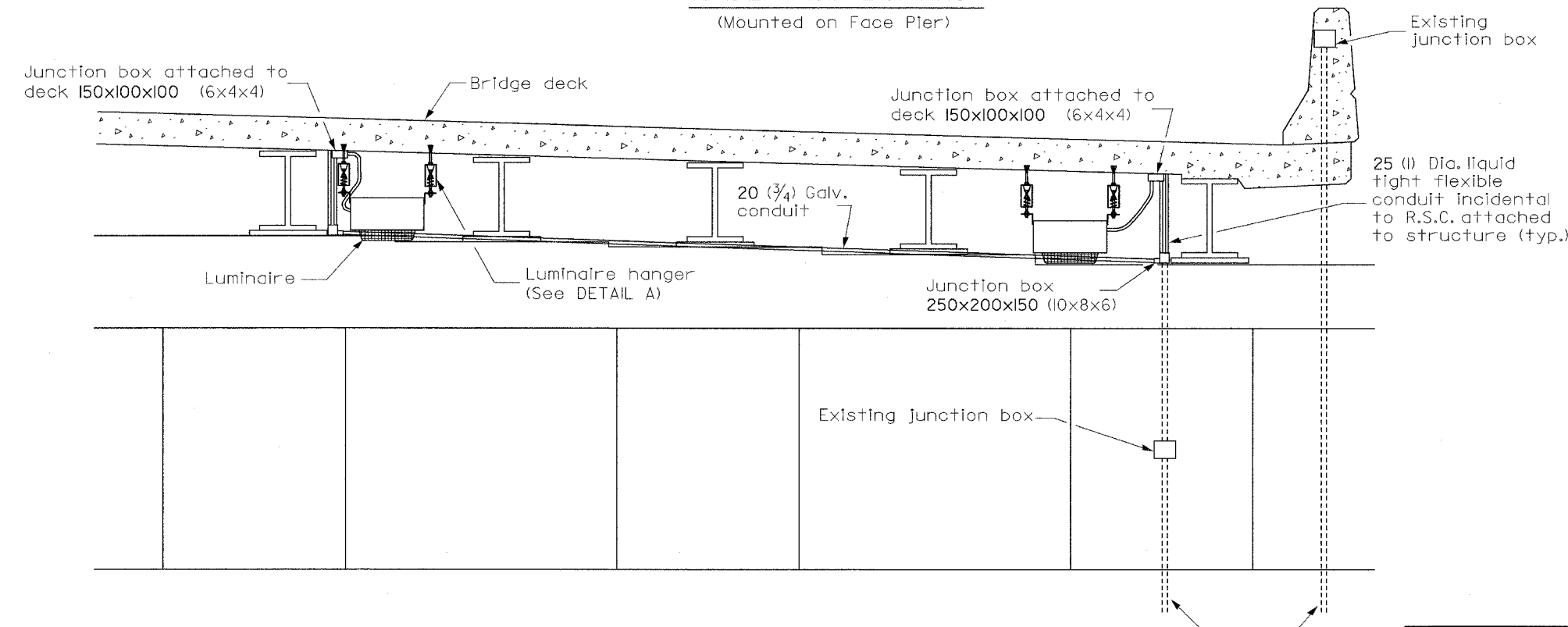

UNDERPASS LIGHTING
(Mounted to Bridge Deck)

DATE	REVISIONS

UNDERPASS LIGHTING	
--------------------	--