

| ROUTE NO. | SECTION | COUNTY | TOTAL SHEETS | SHEET NO. |
|-----------|----------------|--------|--------------|-----------|
| C.H. 16 | 04-00209-01-BR | PIATT | 18 | 10 |
| ILLINOIS | | | | |

CONTRACT NO. 91339
Sheet 7 of 15

GENERAL NOTES

Furnish steel plates in segments of 20 feet maximum length. Maximum space between installed segments shall be $\frac{3}{16}$ ". Seal space with silicone sealant suitable for structural steel.

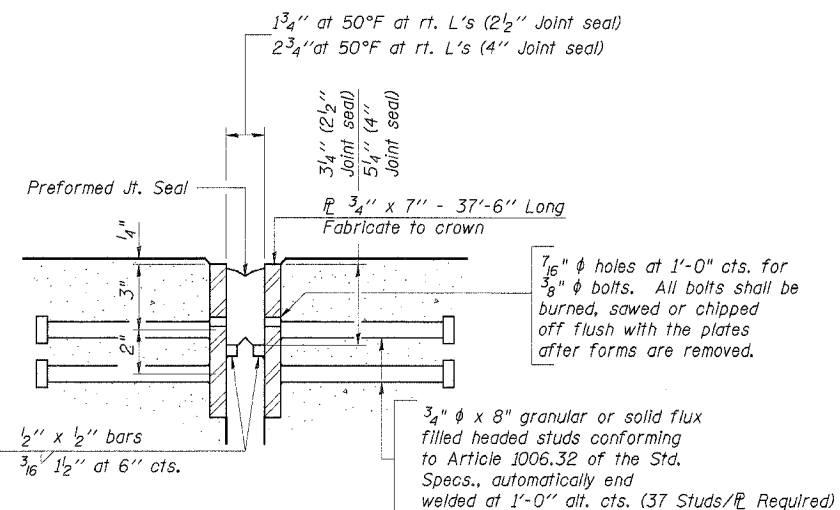

SECTION THRU EXPANSION JOINT
(2 1/2" and 4" joint seals)

| Bridge Joint System (Expansion) | | | |
|---------------------------------|-----------------|------------------------------------|------------------------------------|
| Location | Design Movement | Required Preformed Joint Seal Size | Required Strip Seal Rated movement |
| W. Abut. | 1" | 2 1/2" | 1" |
| E. Abut. | 1 5/8" | 4" | 2" |

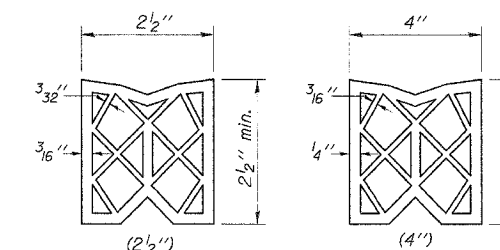

PREFORMED JOINT SEAL

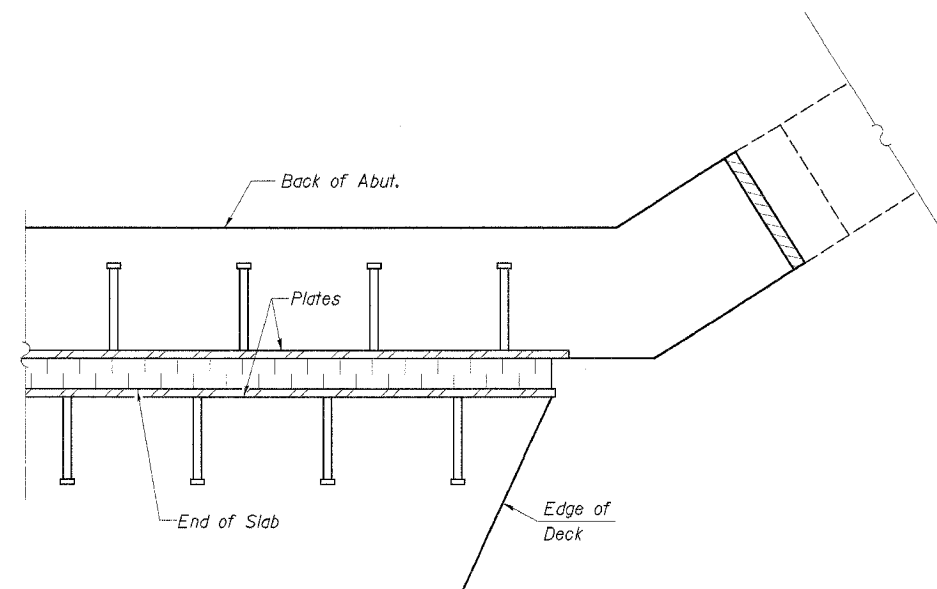

PLAN @ END OF DECK

BILL OF MATERIAL

| Item | Unit | Total |
|----------------------------------------|------|-------|
| Bridge Joint System (Expansion) 1" | Foot | 38 |
| Bridge Joint System (Expansion) 1 5/8" | Foot | 38 |

(Sheet 1 of 2)

REHABILITATION PROJECT

| | |
|----------|--------|
| DESIGNED | A.R.K. |
| CHECKED | S.F.M. |
| DRAWN | S.A.P. |
| CHECKED | F.J.S. |

BRIDGE JOINT SYSTEM - EXPANSION
(PREFORMED JOINT SEAL)
C.H. 16 OVER LAKE FORK
SECTION 04-00209-01-BR
PIATT COUNTY
STATION 29+55

4440 ASH GROVE
SPRINGFIELD, IL 62711
(217) 793-8600
oasinc@famvid.com

OZYURT AND STONE, INC.
CONSULTING ENGINEERS

JOB NO.: 0418
FILE: 0418JOINT1.DGN
DATE: 05-23-05