

ROUTE FAI 290	SECTION 2011-047-BP	COUNTY COOK	TOTAL SHEETS 31	SHEET NUMBER 13
------------------	------------------------	----------------	--------------------	--------------------

CONTRACT NO. 60P57

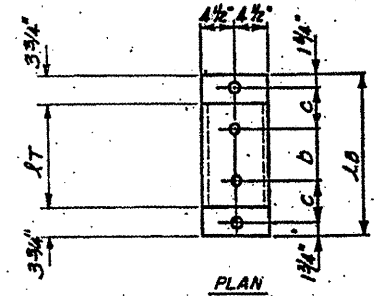
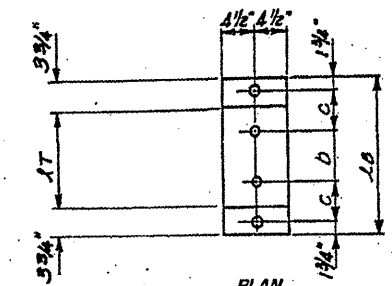
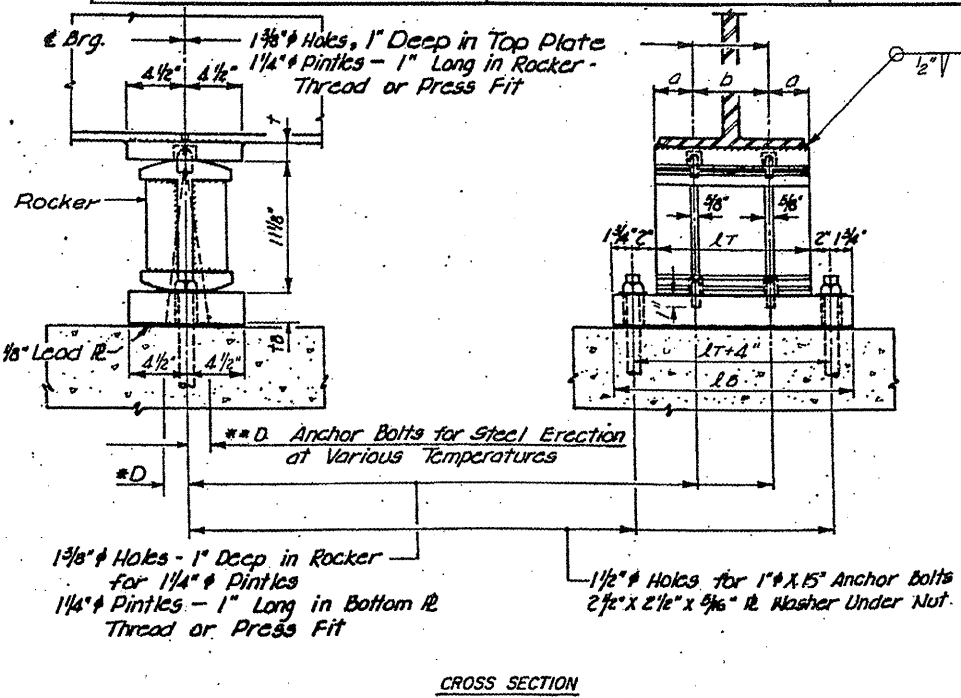
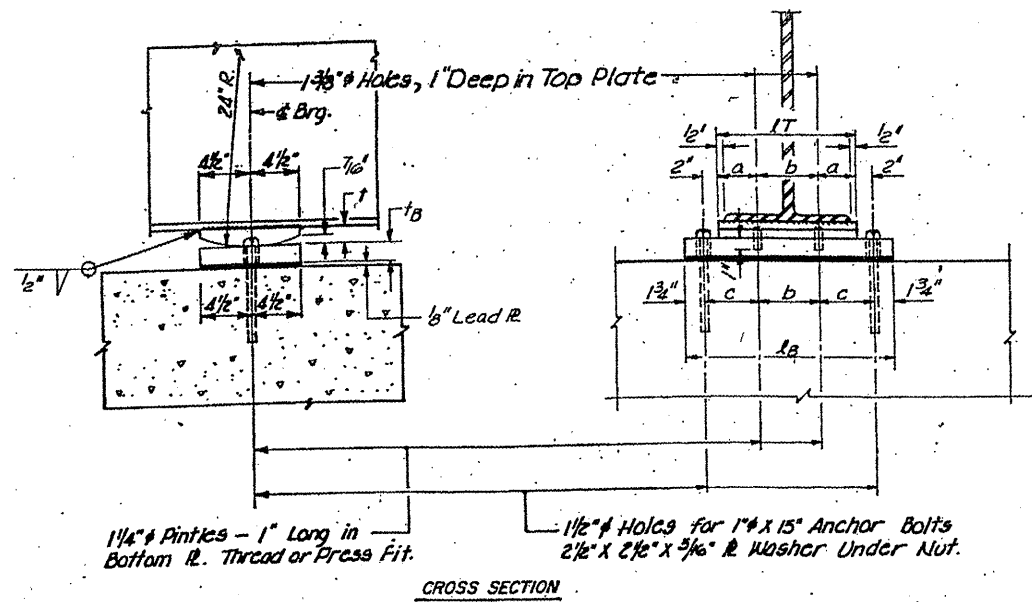

FOR INFORMATION ONLY

FIXED BEARING DETAILS

EXPANSION BEARING DETAILS

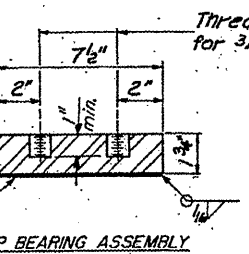
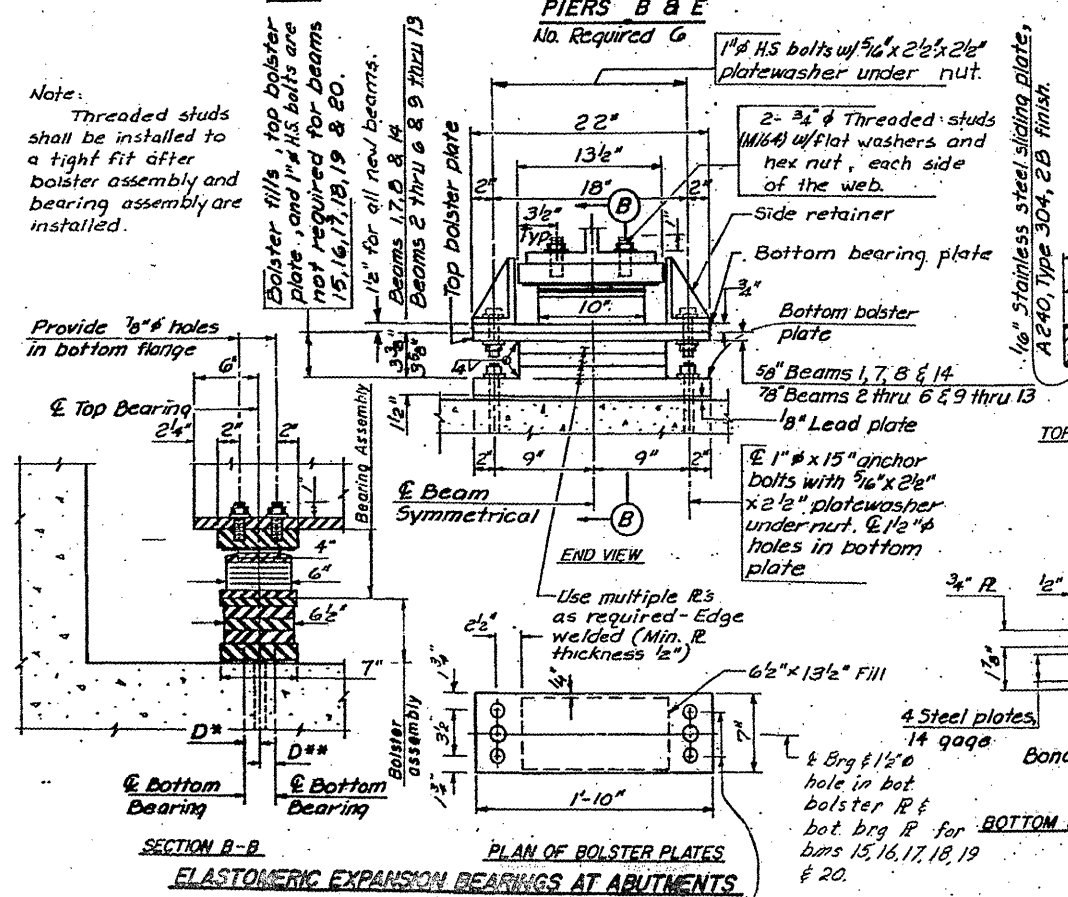

PLAN OF TFE

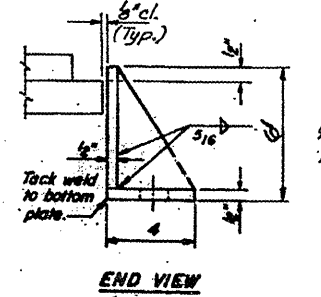
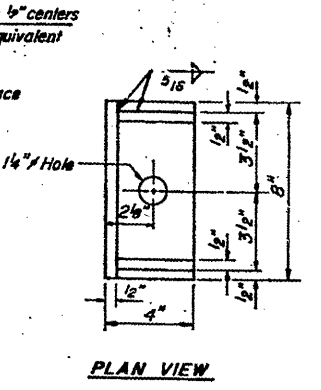
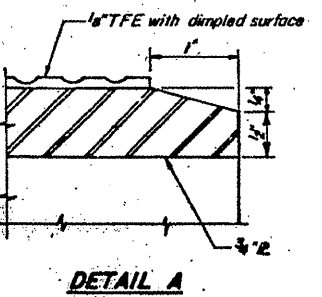

SIDE RETAINER

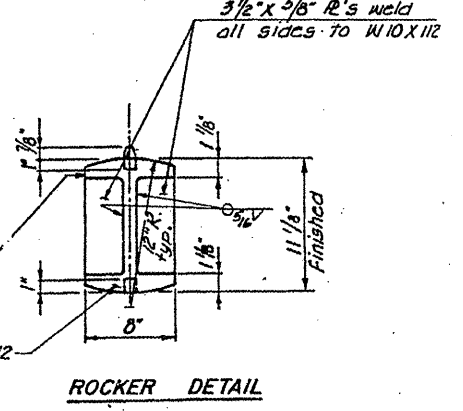
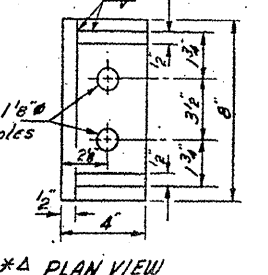
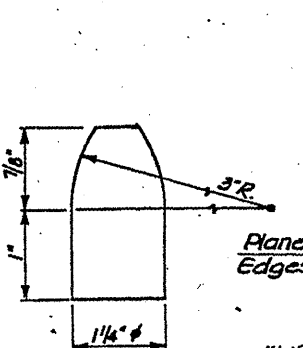

SHEET 3 OF 3

ILLINOIS DEPARTMENT OF TRANSPORTATION

EXISTING BRIDGE PLAN

SN 016-0083, -0084 (BRIDGE 1 & 2)