

# INFORMATIONAL WARNING SIGN (FOR NARROW TRAVEL LANES)

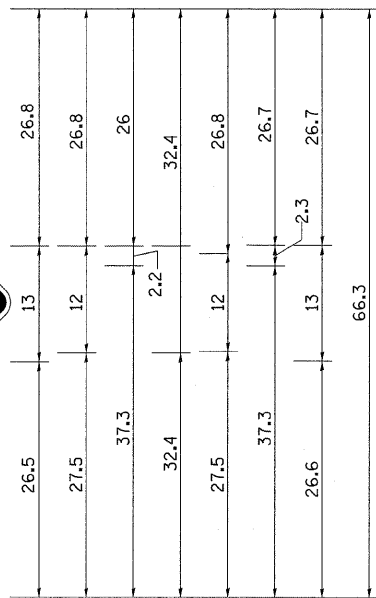

**NOTES**  
 W12-2 - Horizontal Clearance Sign  
 48.0" across sides, 1.9" Radius,  
 0.8" Border, 0.5" Indent, Black on  
 Orange; Standard Arrow Custom  
 10.4" X 8.1" 180° Black 11 Inch  
 D Series Lettering; Standard Arrow  
 Custom 10.4" X 8.1" 0°

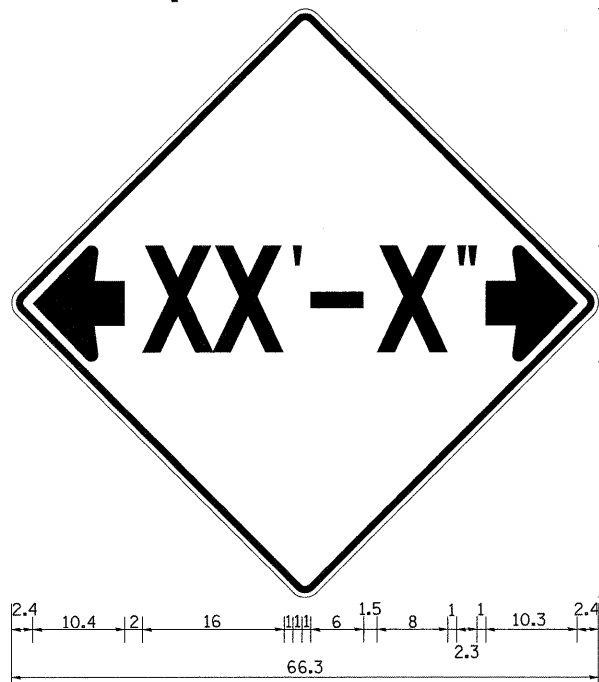

W12-I103 (Width Is 8D);  
 No border, Black on White;  
 [MAX WIDTH] D;

No border, Black on Orange;  
 [XX'-XX''] D;

No border, Black on White;  
 [X MILES] D; [AHEAD] D;

All work to furnish and install these signs shall be included in the cost of the Traffic Control Standards and shall not be paid for separately.

ALL DIMENSIONS ARE IN INCHES UNLESS OTHERWISE NOTED.

REVISED - 5-15-09

# WITNESS MARKER FOR PERMANENT SURVEY MARKERS, TYPE II

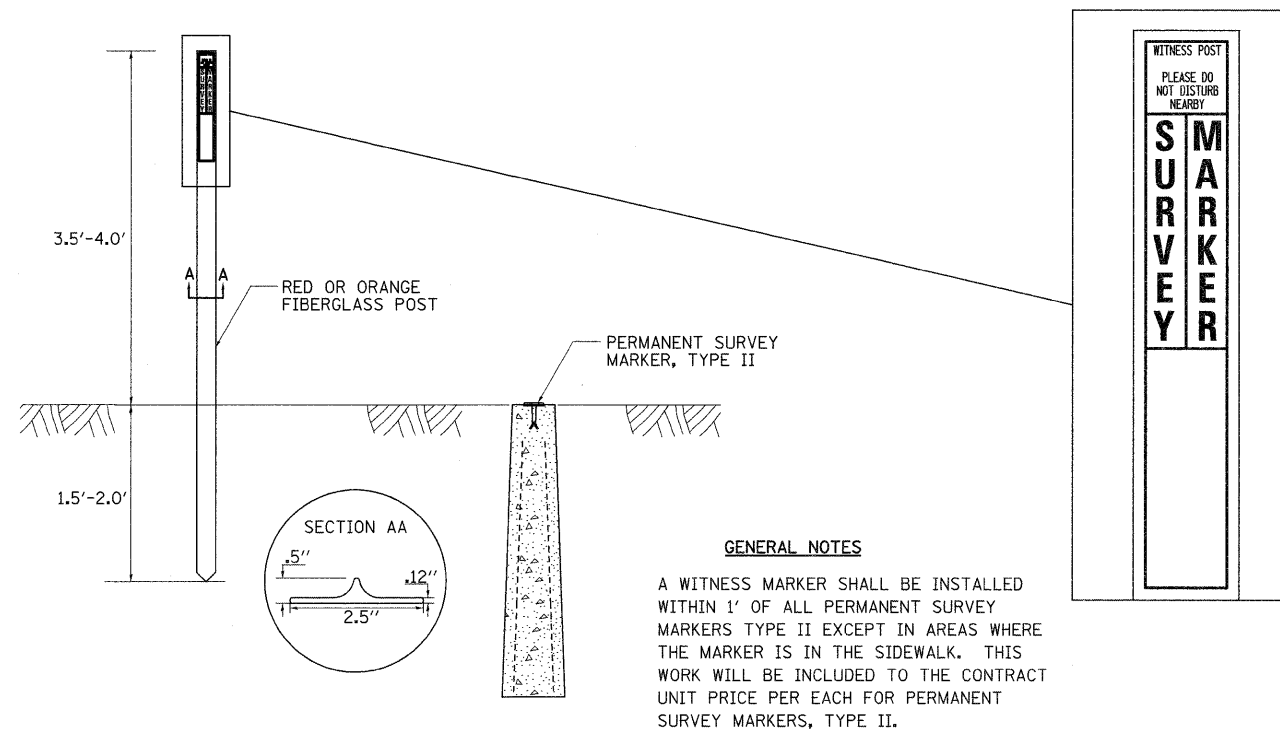

# PERMANENT SURVEY MARKERS, TYPE II

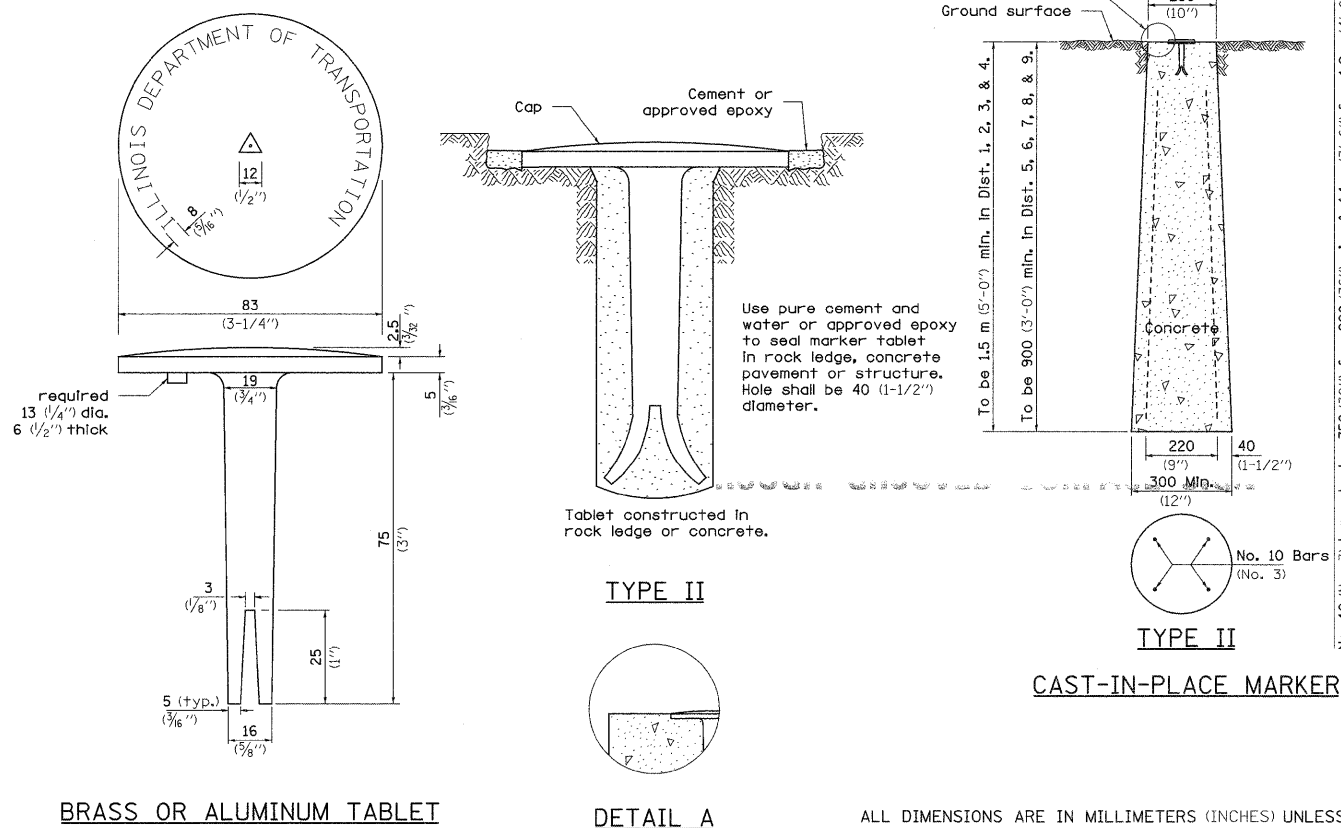

BRASS OR ALUMINUM TABLET

DETAIL A

ALL DIMENSIONS ARE IN MILLIMETERS (INCHES) UNLESS OTHERWISE NOTED.

REVISED - REVISED -	REGION 2 / DISTRICT 2 STANDARD				F.A.P. RTE.	SECTION	COUNTY	TOTAL SHEETS	SHEET NO.		
REVISED -					316	*	LEE	216	170		
REVISED -					SCALE: 50.0000' = 1" SHEET NO. OF SHEETS STA. TO STA.				CONTRACT NO. 64D57		
REVISED -					SCALE: 50.0000' = 1" SHEET NO. OF SHEETS STA. TO STA.				FED. ROAD DIST. NO. ILLINOIS FED. AID PROJECT		