

F.A.P. RTE.	SECTION	COUNTY	TOTAL SHEETS	SHEET NO.
326	(5CS,13C,10B,109R)	KENDALL	931	403
STA. TO STA.				
FED. ROAD DIST. NO.			ILLINOIS FED. AID PROJECT	

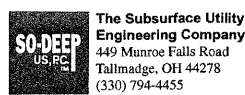

So-Deep Test Hole Certification Form - Metric

City, County, State: **CITY OF YORKVILLE, IL**
 Gen. Loc: **S.R.47 IN FRONT OF BLDG. #6780**
 Recorded Size/Material/Type: **102MM UNK. TYPE (NICOR) GAS LINE**
 Foreman/Truck#/Form By: **J. CLINE / 219 / R. MOONEY**

So-Deep Corporate Office
 8397 Euclid Avenue
 Manassas Park, VA 20111
 (703)361-6005

Control # **SILC078**
 Test Hole # **41**
 Plan Scale **1:250**
 Sheet # **33**
 Proposed **GRADE CHANGE**
 Date **JULY 21, 2009**

B.M. 1 Elev. = **216.388M** Description: **CHIS "X" SET TOP RIM STM MH, 16M± RT OF CL STA 19+631±, S.R. 47**
 is GIVEN
 B.M. 2 Elev. = **216.471M** Description: **CHIS "X" SET TOP RIM STM MH, 16M± RT OF CL STA 19+697±, S.R. 47**
 is GIVEN
 Benchmarks check **BY 0.007M**
 Elevations are referenced to **B.M.#2**

SO-DEEP will attempt to use the BMHI most applicable to your design. If however, BM's differ by more than 0.015 m, resulting differences could cause design conflicts.

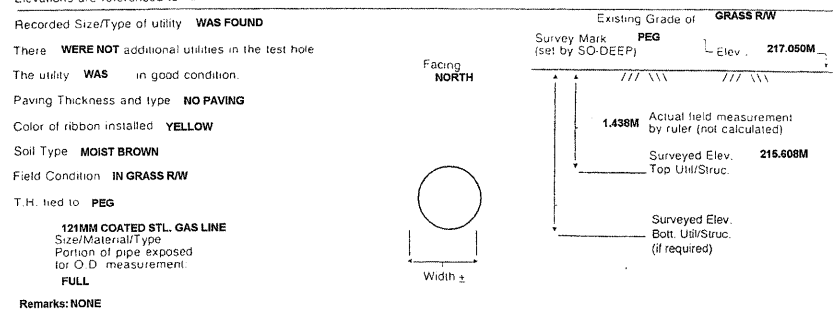

Remarks: NONE

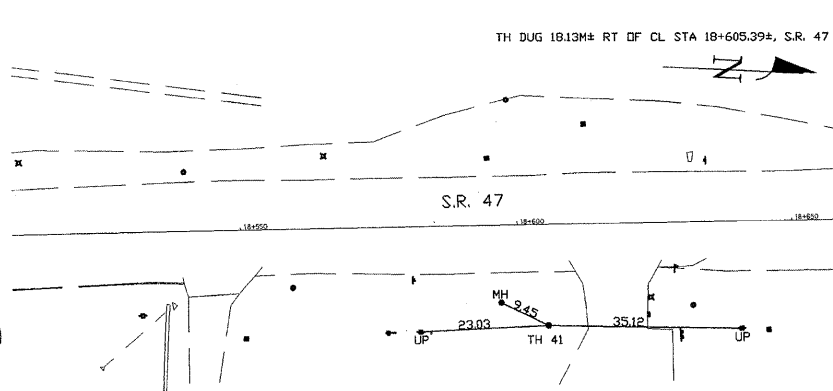

- RW = Rights of Way
- N.T.S. = Not to Scale
- PC = Precast Concrete
- COND. = Conduit
- CONC. = Concrete
- O.D. = Outside Diameter
- C.I. = Cast Iron
- D.I. = Ductile Iron
- RPC = Rough Pour Concrete
- CL = Centerline
- T.C. = Terra Cotta
- PLAS. = Plastic
- BL = Base Line
- ELEC. = Electric
- TELE. = Telephone
- T.H. = Test Hole
- SW = Sidewalk
- DW = Driveway
- BM = Benchmark
- C.B. = Catch Basin
- GV = Gas Valve
- Sewer Manhole
- Test Hole
- Fire Hydrant
- Pole
- Fence Line
- Electric Manhole
- Valve
- Water Meter
- Telephone Manhole
- Telephone Pedestal

Performing out-of-sight work...with vision!
 All values are shown in meters (m) or millimeters (mm).
 To convert to feet multiply meters by 3.2808.
 Note: To eliminate mistakes and check this work, So-Deep suggests you scale and plot all dimensions onto the plans and review all elevations carefully. So-Deep is responsible only for information shown on our forms.

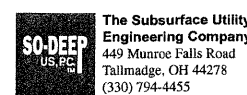

So-Deep Test Hole Certification Form - Metric

City, County, State: **CITY OF YORKVILLE, IL**
 Gen. Loc: **S.R. 47, BTWN. BEAVER ST. AND COLONIAL PKWY.**
 Recorded Size/Material/Type: **102MM W/STL. (NICOR) GAS LINE**
 Foreman/Truck#/Form By: **J. CLINE / 219 / R. MOONEY**

So-Deep Corporate Office
 8397 Euclid Avenue
 Manassas Park, VA 20111
 (703)361-6005

Control # **SILC078**
 Test Hole # **42**
 Plan Scale **1:250**
 Sheet # **7**
 Proposed **GRADE CHANGE**
 Date **JULY 10, 2009**

B.M. 1 Elev. = **202.126M** Description: **CHIS "X" SET TOP RIM SMH, 24M± LT OF CL STA 19+668±, S.R. 47**
 is GIVEN
 B.M. 2 Elev. = **201.219M** Description: **CHIS "X" SET TOP RIM SMH, 24M± LT OF CL STA 19+741±, S.R. 47**
 is GIVEN
 Benchmarks check **BY 0.001M**
 Elevations are referenced to **B.M.#1**

SO-DEEP will attempt to use the BMHI most applicable to your design. If however, BM's differ by more than 0.015 m, resulting differences could cause design conflicts.

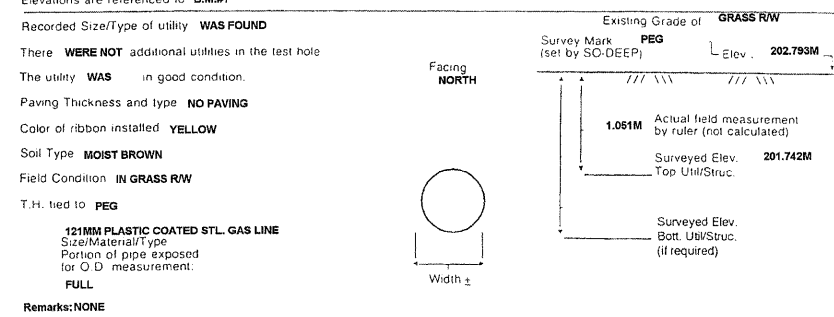

Remarks: NONE

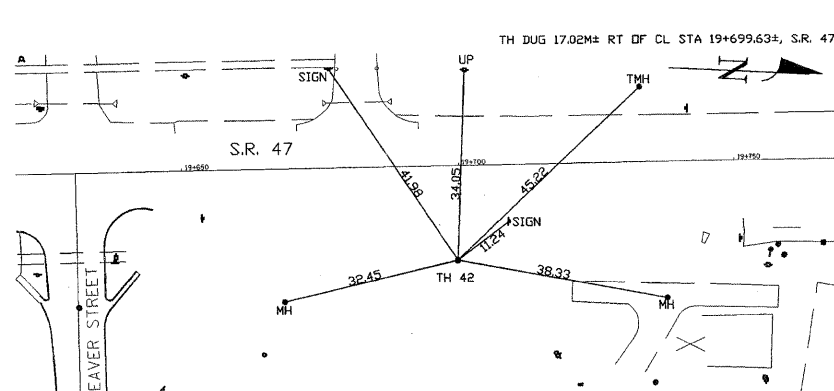

- RW = Rights of Way
- N.T.S. = Not to Scale
- PC = Precast Concrete
- COND. = Conduit
- CONC. = Concrete
- O.D. = Outside Diameter
- C.I. = Cast Iron
- D.I. = Ductile Iron
- RPC = Rough Pour Concrete
- CL = Centerline
- T.C. = Terra Cotta
- PLAS. = Plastic
- BL = Base Line
- ELEC. = Electric
- TELE. = Telephone
- T.H. = Test Hole
- SW = Sidewalk
- DW = Driveway
- BM = Benchmark
- C.B. = Catch Basin
- GV = Gas Valve
- Sewer Manhole
- Test Hole
- Fire Hydrant
- Pole
- Fence Line
- Electric Manhole
- Valve
- Water Meter
- Telephone Manhole
- Telephone Pedestal

Performing out-of-sight work...with vision!
 All values are shown in meters (m) or millimeters (mm).
 To convert to feet multiply meters by 3.2808.
 Note: To eliminate mistakes and check this work, So-Deep suggests you scale and plot all dimensions onto the plans and review all elevations carefully. So-Deep is responsible only for information shown on our forms.

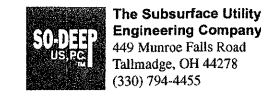

So-Deep Test Hole Certification Form - Metric

City, County, State: **CITY OF YORKVILLE, IL**
 Gen. Loc: **S.R. 47, BTWN. BEAVER ST. AND COLONIAL PKWY.**
 Recorded Size/Material/Type: **102MM W/STL. (NICOR) GAS LINE**
 Foreman/Truck#/Form By: **J. CLINE / 219 / R. MOONEY**

So-Deep Corporate Office
 8397 Euclid Avenue
 Manassas Park, VA 20111
 (703)361-6005

Control # **SILC078**
 Test Hole # **43**
 Plan Scale **1:250**
 Sheet # **7**
 Proposed **GRADE CHANGE**
 Date **JULY 10, 2009**

B.M. 1 Elev. = **202.126M** Description: **CHIS "X" SET TOP RIM SMH, 24M± LT OF CL STA 19+668±, S.R. 47**
 is GIVEN
 B.M. 2 Elev. = **201.219M** Description: **CHIS "X" SET TOP RIM SMH, 24M± LT OF CL STA 19+741±, S.R. 47**
 is GIVEN
 Benchmarks check **BY 0.001M**
 Elevations are referenced to **B.M.#1**

SO-DEEP will attempt to use the BMHI most applicable to your design. If however, BM's differ by more than 0.015 m, resulting differences could cause design conflicts.

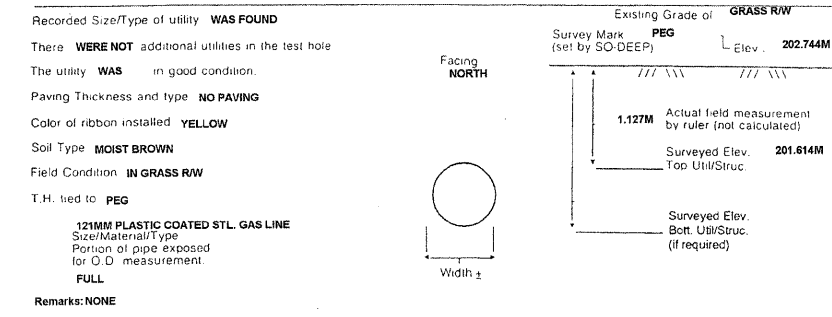

Remarks: NONE

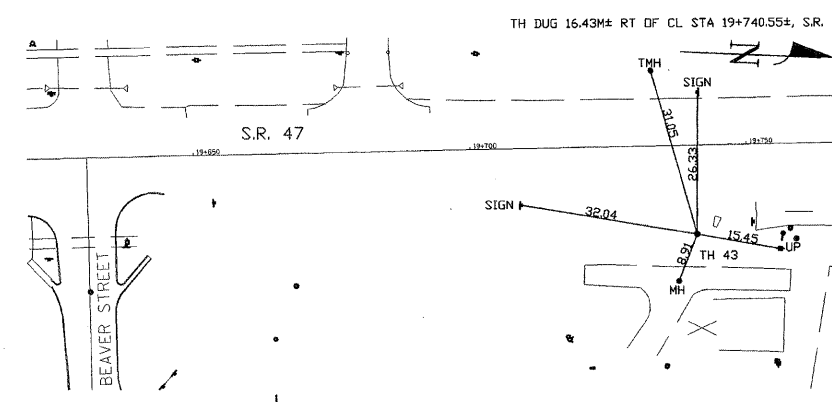

- RW = Rights of Way
- N.T.S. = Not to Scale
- PC = Precast Concrete
- COND. = Conduit
- CONC. = Concrete
- O.D. = Outside Diameter
- C.I. = Cast Iron
- D.I. = Ductile Iron
- RPC = Rough Pour Concrete
- CL = Centerline
- T.C. = Terra Cotta
- PLAS. = Plastic
- BL = Base Line
- ELEC. = Electric
- TELE. = Telephone
- T.H. = Test Hole
- SW = Sidewalk
- DW = Driveway
- BM = Benchmark
- C.B. = Catch Basin
- GV = Gas Valve
- Sewer Manhole
- Test Hole
- Fire Hydrant
- Pole
- Fence Line
- Electric Manhole
- Valve
- Water Meter
- Telephone Manhole
- Telephone Pedestal

Performing out-of-sight work...with vision!
 All values are shown in meters (m) or millimeters (mm).
 To convert to feet multiply meters by 3.2808.
 Note: To eliminate mistakes and check this work, So-Deep suggests you scale and plot all dimensions onto the plans and review all elevations carefully. So-Deep is responsible only for information shown on our forms.

FILE: 391-486-Utility Test Hole sheets.dgn PLOTTED: 8/11/2011

REVISIONS		ILLINOIS DEPARTMENT OF TRANSPORTATION
NAME	DATE	
		UTILITY TEST HOLE RECORD
DATE		DRAWN BY
		CHECKED BY

HMG JOB NO. 5122