















F.A.P. RTE.	SECTION	COUNTY	TOTAL SHEETS	SHEET NO.
326	*	KENDALL	931	596
STA. N/A		TO STA. N/A		
FED. ROAD DIST. NO. 5 ILLINOIS FED. AID PROJECT				
*15CS, 13C, 108, 109R				

### TEMPORARY TRAFFIC SIGNAL LEGEND

-  TEMPORARY CONTROLLER AND CABINET
-  TEMPORARY TRAFFIC SIGNAL HEAD WITH BACKPLATE
-  TEMPORARY PEDESTRIAN PUSH-BUTTON
-  TEMPORARY PED. SIGNAL HEAD, BRACKET MOUNTED
-  VIDEO DETECTION SYSTEM
-  TEMPORARY WOOD POLE (CLASS 5) 14 m MINIMUM
-  TEMPORARY SPAN WIRE, TETHER WIRE AND CABLE
-  GUY WIRES
-  TEMPORARY LUMINAIRE, SODIUM VAPOR, 250 WATT

### EXISTING SIGNAL LEGEND

-  HANDHOLE
-  DOUBLE HANDHOLE
-  MAST ARM ASSEMBLY AND POLE
-  CONTROLLER
-  JUNCTION BOX
-  SIGNAL POST

**NOTE:**  
 DURING CONSTRUCTION, FLAGGING OR OTHER OPERATIONS SHALL NOT CREATE CONDITIONS WHERE VEHICLES CAN BE QUEUED ACROSS THE RAILROAD TRACKS. IF THE QUEUING OF VEHICLES ACROSS THE TRACKS CANNOT BE AVOIDED, A UNIFORMED LAW ENFORCEMENT OFFICER OR FLAGGER SHALL BE PROVIDED AT THE CROSSING TO PREVENT VEHICLES FROM STOPPING ON THE TRACKS, EVEN IF AUTOMATIC WARNING DEVICES ARE IN PLACE. THE COST OF THIS WORK SHALL BE INCLUDED IN THE ASSOCIATED PAY ITEMS FOR TRAFFIC CONTROL AND PROTECTION.

WHERE POSSIBLE, TEMPORARY SPAN WIRES SHALL BE PLACED IN FRONT OF PERMANENT TRAFFIC SIGNALS. ALL WOOD POLE LOCATIONS SHALL BE APPROVED BY THE ENGINEER PRIOR TO PLACEMENT.

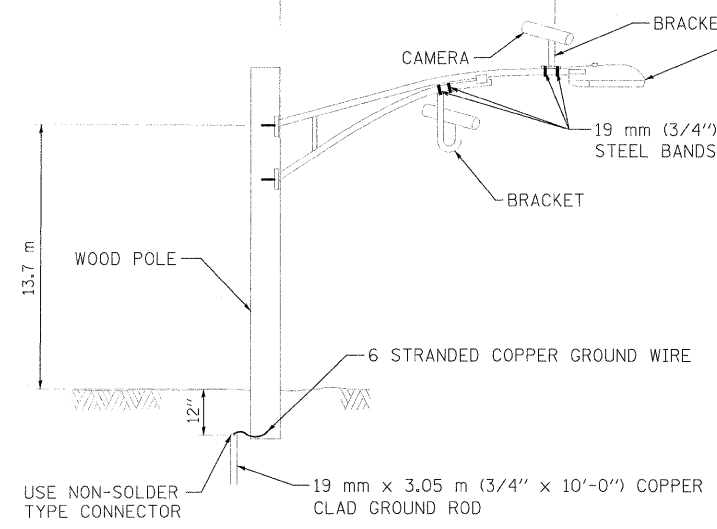
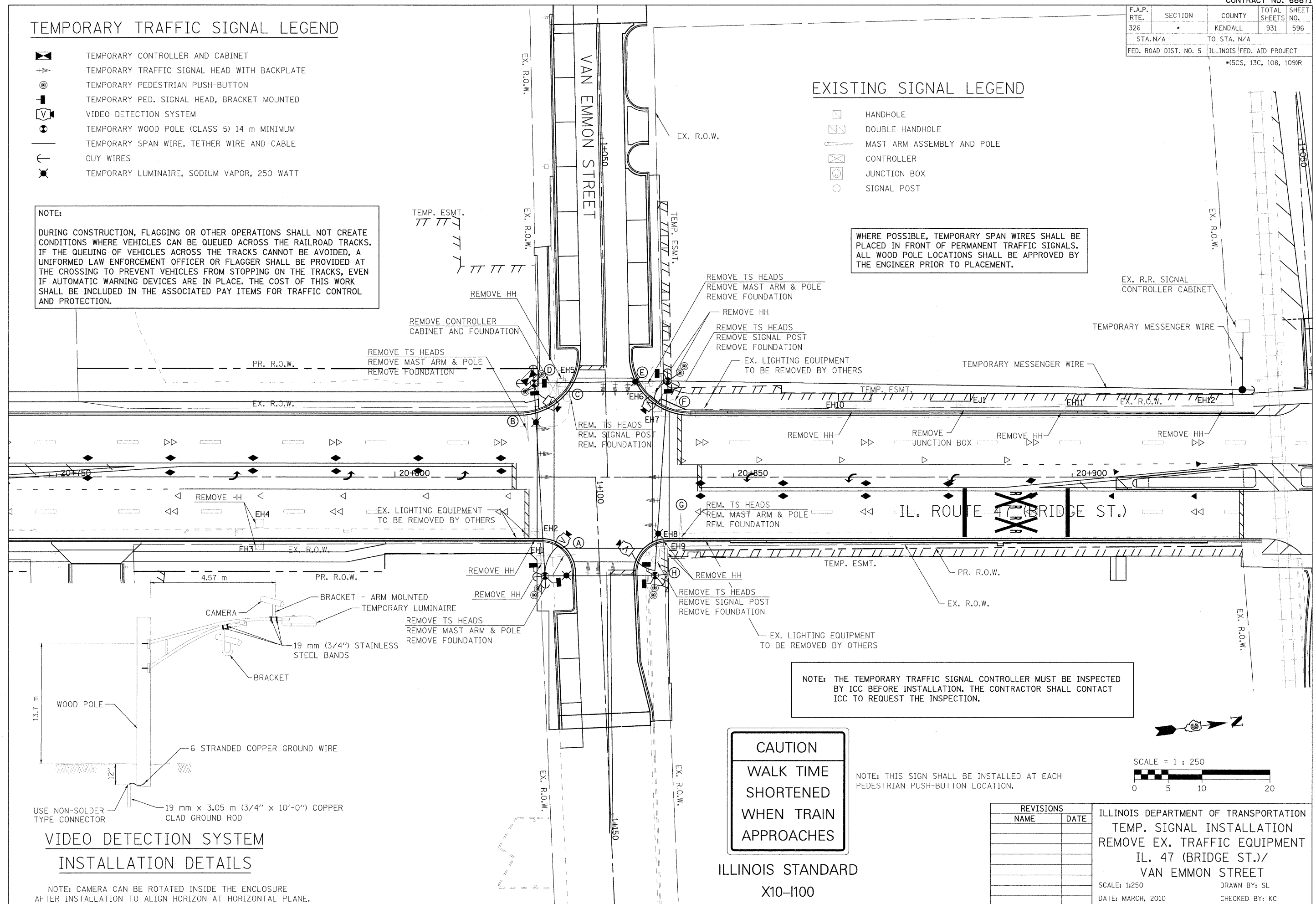

### VIDEO DETECTION SYSTEM INSTALLATION DETAILS

NOTE: CAMERA CAN BE ROTATED INSIDE THE ENCLOSURE AFTER INSTALLATION TO ALIGN HORIZON AT HORIZONTAL PLANE.

**CAUTION**  
 WALK TIME  
 SHORTENED  
 WHEN TRAIN  
 APPROACHES

ILLINOIS STANDARD  
 X10-1100

NOTE: THE TEMPORARY TRAFFIC SIGNAL CONTROLLER MUST BE INSPECTED BY ICC BEFORE INSTALLATION. THE CONTRACTOR SHALL CONTACT ICC TO REQUEST THE INSPECTION.

NOTE: THIS SIGN SHALL BE INSTALLED AT EACH PEDESTRIAN PUSH-BUTTON LOCATION.

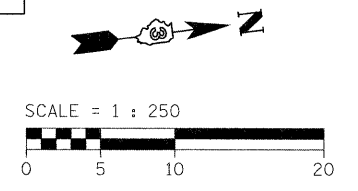

REVISIONS	
NAME	DATE

ILLINOIS DEPARTMENT OF TRANSPORTATION  
 TEMP. SIGNAL INSTALLATION  
 REMOVE EX. TRAFFIC EQUIPMENT  
 IL. 47 (BRIDGE ST.)/  
 VAN EMMON STREET  
 SCALE: 1:250  
 DATE: MARCH, 2010  
 DRAWN BY: SL  
 CHECKED BY: KC

PLOT DATE = 8/11/2011  
 FILE NAME = h:\5122\design\596-597\van\_emmon\_rem.dgn  
 USER = jusepedesol  
 SCALE = 6:2500  
 USER NAME = jusepedesol