

F.A.P. RTE.	SECTION	COUNTY	TOTAL SHEETS	SHEET NO.
326	(5CS,13C,108,109)R	KENDALL	931	666
STA.		TO STA.		
FED. ROAD DIST. NO.		ILLINOIS FED. AID PROJECT		

MATERIAL LIST
JUNCTION BOX NO. 1
(For Information Only)

BAR	NO.	SIZE	LENGTH (m)	SHAPE
a ₉₁ (E)	49	#22	2.36	C
a ₉₃ (E)	49	#16	1.80	—
h ₉₀ (E)	17	#19	4.93	—
h ₉₉ (E)	17	#13	4.93	—
Concrete Structures			m ³	4.1
Reinforcement Bars, Epoxy Coated			kg	760

Cut a₉₁(E), a₉₃(E), h₉₀(E), and h₉₉(E) bars in the field to miss the MH opening in the top slab.

BILL OF MATERIAL

ITEM	UNIT	QUANTITY
Junction Box No. 1	L. Sum	1

Notes:

- Junction Box walls shall be constructed of precast or cast-in-place concrete in accordance with Section 602 of the Standard Specifications and Special Provisions.
- Steps shall be required for all Junction Boxes. Steps shall be spaced at 300 to 400 cts. and in accordance with Standard 602701 and Article 602.08 of the Standard Specifications.
- Reinforcement Bars shall conform to the requirements of ASTM A 706M, Gr. 420.
- All Reinforcement Bars for Junction Boxes shall be epoxy coated.
- Material List is shown for informational purposes only. Quantities of "Concrete Structures" and "Reinforcement Bars, Epoxy Coated" shall be included in the cost of Junction Box No. 1. See Special Provisions.
- All dimensions are in millimeters unless otherwise shown.

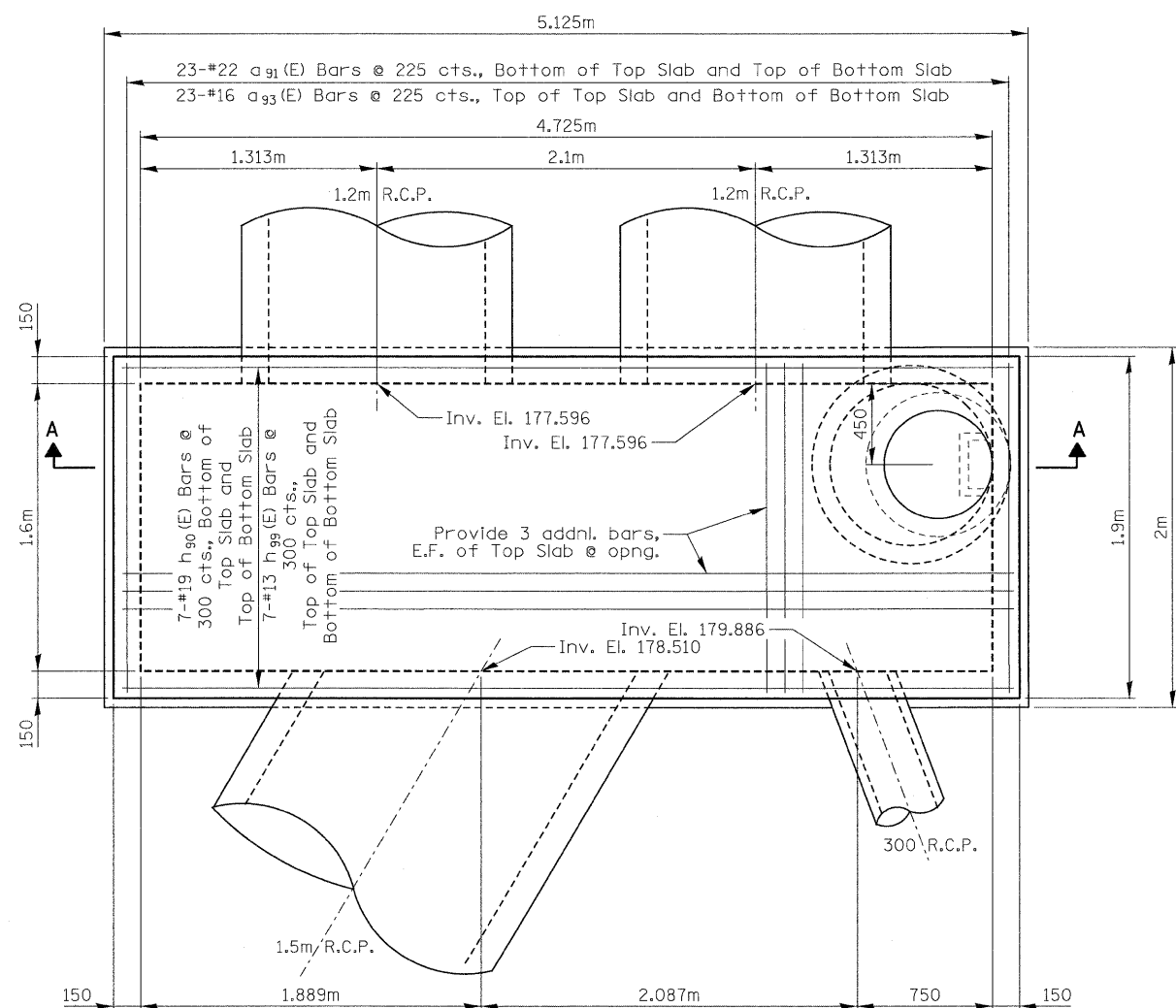
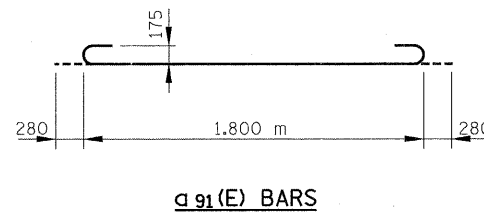

PLAN - JUNCTION BOX NO. 1

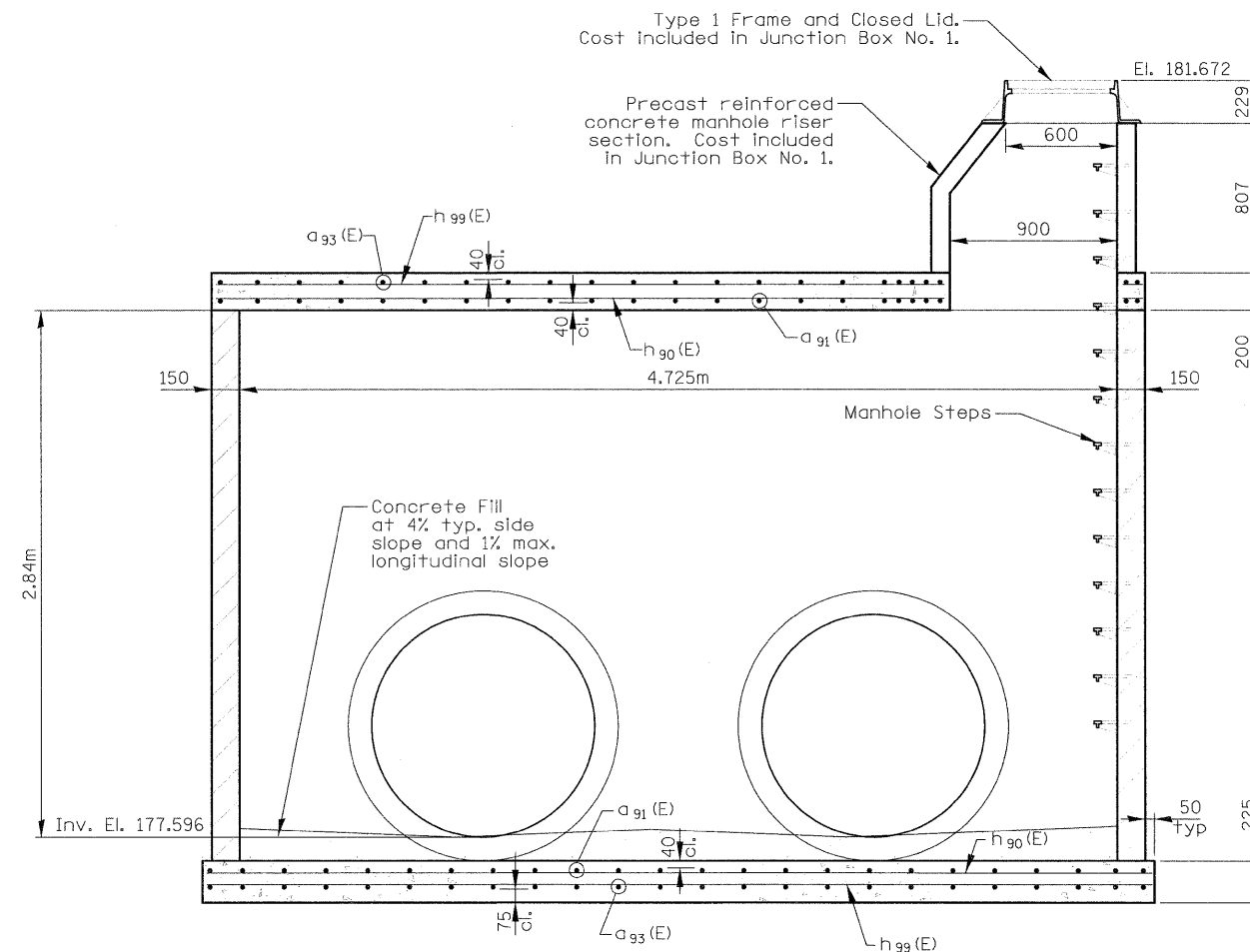

SECTION A-A

REVISIONS	
NAME	DATE

ILLINOIS DEPARTMENT OF TRANSPORTATION

DETAILS
JUNCTION BOX NO. 1

DATE _____ DRAWN BY _____
CHECKED BY _____

FILE: 666_juncbx1_sht.dgn
PLOTTED: 8/11/2011

HMG JOB NO. 5122