

| F.A.P. RTE.         | SECTION            | COUNTY                    | TOTAL SHEETS | SHEET NO. |
|---------------------|--------------------|---------------------------|--------------|-----------|
| 326                 | (5CS,13C,108,109)R | KENDALL                   | 931          | 690       |
| STA.                |                    | TO STA.                   |              |           |
| FED. ROAD DIST. NO. |                    | ILLINOIS FED. AID PROJECT |              |           |

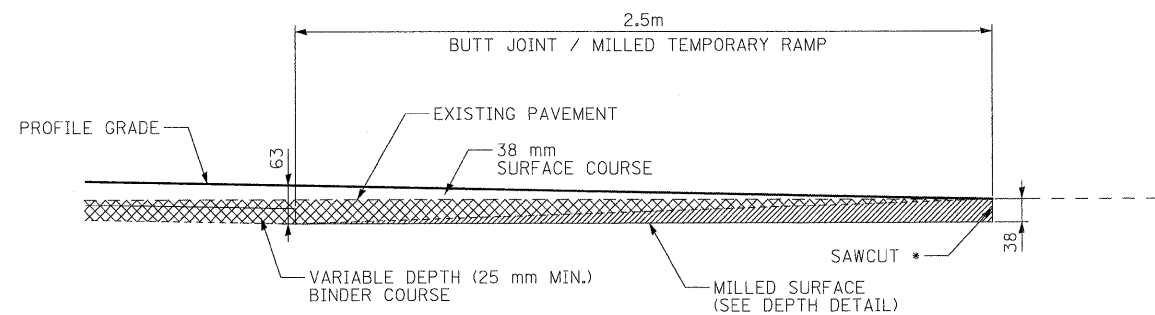

\* INCLUDED IN COST OF BUTT JOINT

- PAVEMENT REMOVED AS HMA SURFACE REMOVAL - VARIABLE DEPTH
- PAVEMENT REMOVED AS HMA SURFACE REMOVAL - BUTT JOINT

**BUTT JOINT / MILLED TEMPORARY RAMP DETAIL**

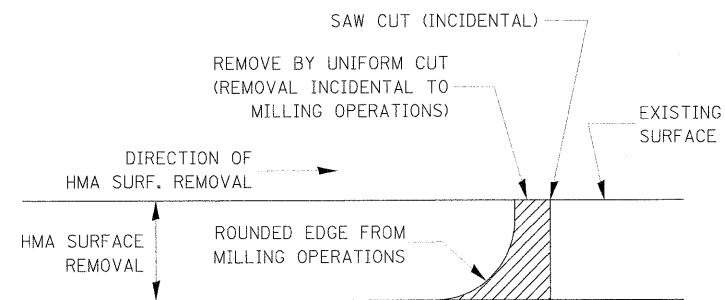

NOTE:

WHEN MILLING OPERATIONS PRODUCE A ROUNDED EDGE, THEN A SAW CUT SHALL BE USED TO MANUFACTURE A PERPENDICULAR EDGE AS SHOWN IN THE DETAIL. THE ENGINEER SHALL BE THE SOLE JUDGE CONCERNING THE USE OF THIS DETAIL.

**HMA DETAIL AT BUTT JOINTS**

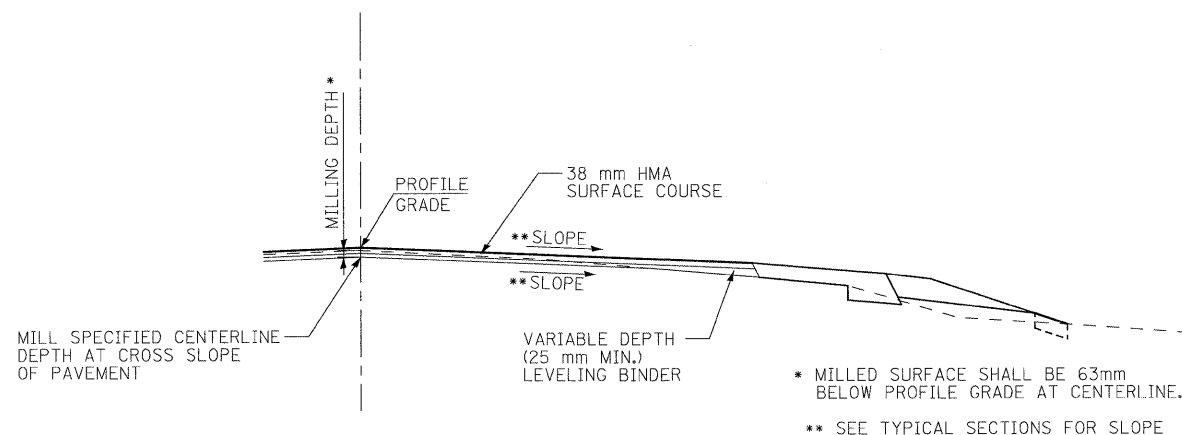

**HMA SURFACE REMOVAL AND OVERLAY DETAIL**

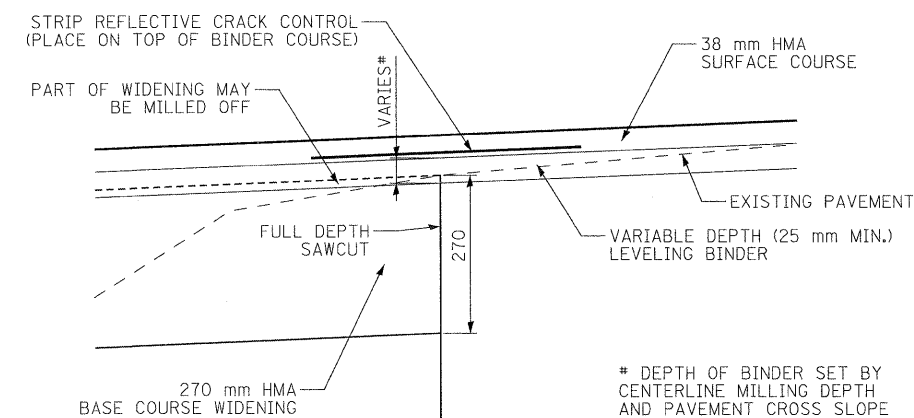

**HMA SURFACE REMOVAL AND OVERLAY DETAIL AT BASE COURSE WIDENING**

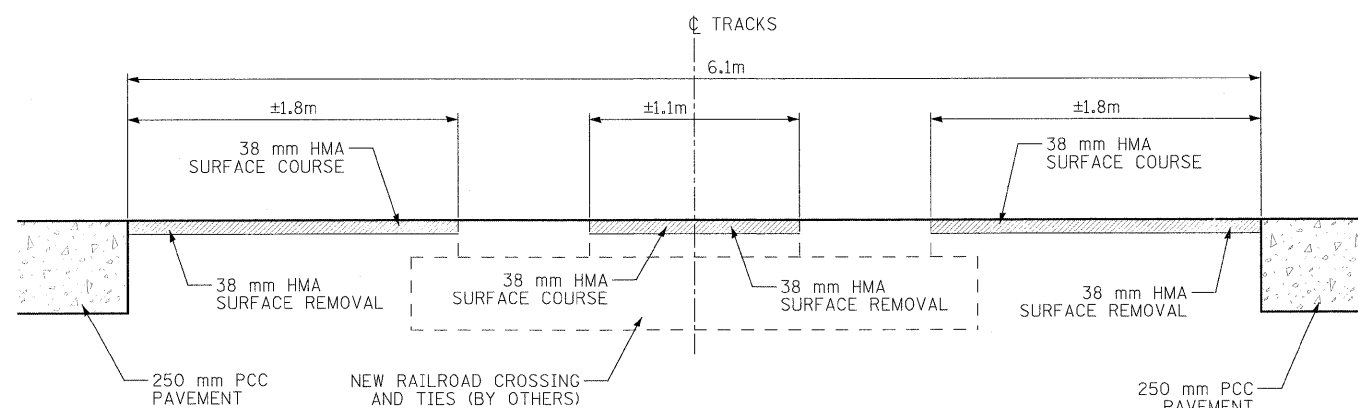

**HMA SURFACE REMOVAL AND OVERLAY AT RAILROAD CROSSING**

SURFACE REMOVAL AT RAILROAD CROSSING SHALL BE PAID FOR AS HMA SURFACE REMOVAL - BUTT JOINT

| REVISIONS |      | ILLINOIS DEPARTMENT OF TRANSPORTATION  |
|-----------|------|--|
| NAME      | DATE |  |
|           |      | <p style="text-align: center;"><b>PAVEMENT DETAILS</b></p> <p style="text-align: right;">DRAWN BY<br/>CHECKED BY</p> |
|           |      |  |
|           |      |  |
|           |      |  |
|           |      |  |
|           |      |  |

FILE: 690-691DET\_SHT-pavement.dgn  
PLOTTED: 8/11/2011

HMG JOB NO. 5122