

PROPOSED LEGEND

- ⑪ PROPOSED HOT-MIX ASPHALT SURFACE REMOVAL, (VARIABLE DEPTH), 2 1/4" AVG.
- ⑫ PROPOSED PAVEMENT REMOVAL
- ⑬ PROPOSED PAVED SHOULDER REMOVAL
- ⑭ PROPOSED GUARDRAIL REMOVAL
- ⑮ PROPOSED HOT-MIX ASPHALT SURFACE COURSE 2", MIX "C", N 50
- ⑯ PROPOSED PAINT PAVEMENT MARKING - LINE 5"
- ⑰ PROPOSED HOT-MIX ASPHALT BASE COURSE, 10"
- ⑱ PROPOSED HOT-MIX ASPHALT SHOULDERS, 2"
- ⑲ PROPOSED AGGREGATE SHOULDERS, TYPE B, 10"
- ⑳ PROPOSED STEEL PLATE BEAM GUARDRAIL, 6 FOOT POST
- ㉑ PROPOSED EARTH EXCAVATION

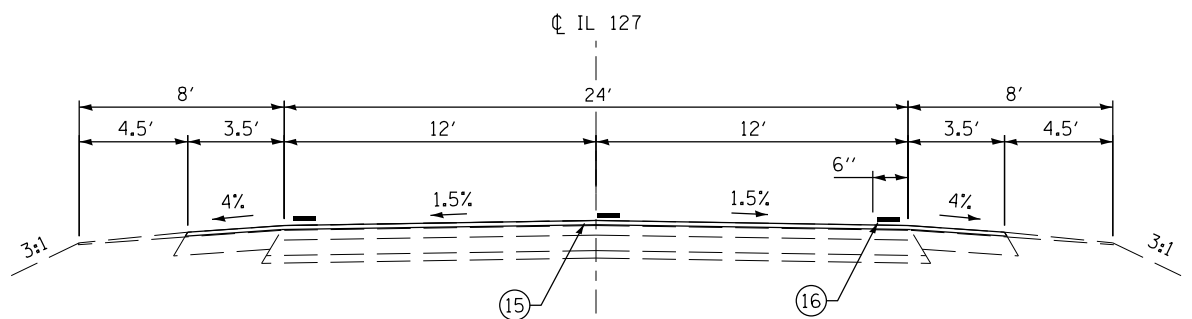

PROPOSED ROADWAY TYPICAL SECTION
STATION 312+28.50 TO STATION 314+55.00

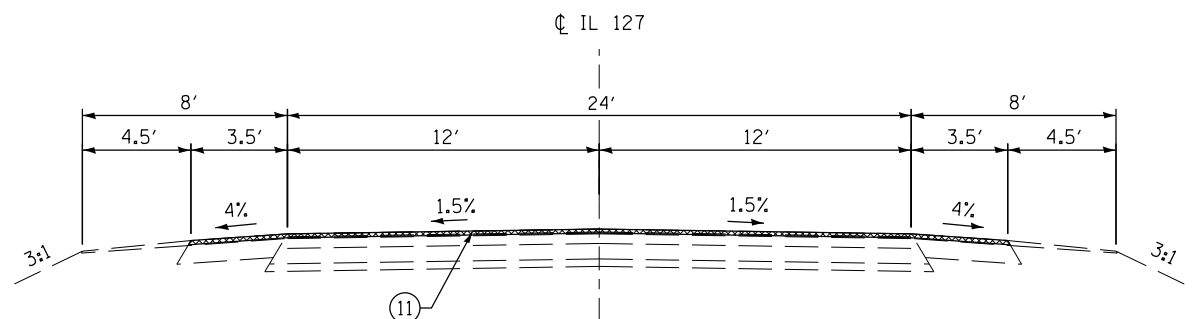

PROPOSED ROADWAY TYPICAL SECTION - REMOVAL
STATION 314+55.00 TO STATION 316+00.00

EXISTING LEGEND

- ① EXISTING BITUMINOUS CONC. SURFACE COURSE SUPERPAVE, MIX D, N50, 1 1/2"
- ② EXISTING LEVELING BINDER SUPERPAVE N50, 3/4"
- ③ EXISTING BITUMINOUS CONC. SURFACE COURSE, 4 1/4"
- ④ EXISTING BITUMINOUS BASE COURSE, 8"
- ⑤ EXISTING SUB-BASE GRANULAR MATERIAL, TYPE A, 4"
- ⑥ EXISTING BITUMINOUS SHOULDERS, 8"
- ⑦ EXISTING BITUMINOUS SHOULDERS, SUPERPAVE
- ⑧ EXISTING AGGREGATE SHOULDERS, TYPE B (WEDGE)
- ⑨ EXISTING STEEL PLATE BEAM GUARDRAIL
- ⑩ EXISTING PAVEMENT MARKING LINE

FILE NAME =	USER NAME = sparksgw	DESIGNED -	REVISED -
et:\pwork\pwork\sparksgw\0281833\0672866-sht-typical.dgn		DRAWN -	REVISED -
PLOT SCALE = 8.0000' / in.		CHECKED -	REVISED -
PLOT DATE = Sep-09-2011 11:34:46AM		DATE -	REVISED -

**STATE OF ILLINOIS
DEPARTMENT OF TRANSPORTATION**

TYPICAL SECTIONS			
SCALE:	SHEET NO. 4 OF 4 SHEETS	STA.	TO STA.

F.A.P. RTE.	SECTION	COUNTY	TOTAL SHEETS	SHEET NO.
42	105B-1	MONTGOMERY	63	7
FED. ROAD DIST. NO. ILLINOIS FED. AID PROJECT			CONTRACT NO. 72B66	