

TYPICAL #E

RAILROAD OMISSION:
 STA. 0+13.85 TO STA. 0+22.42
 STA. 0+22.42 TO STA. 02+58.51
RAILROAD OMISSION:
 STA. 2+58.51 TO STA. 3+73.86
 STA. 3+73.86 TO STA. 15+73.48

PROPOSED LEGEND	
ⓐ	HMA SURFACE REMOVAL, 2"
ⓑ	HMA SURFACE COURSE, MIX "D", N70, 2"
ⓒ	PAVEMENT MARKING LINE

SEE SHEET 7 FOR COMPLETE LIST OF PROPOSED ITEMS

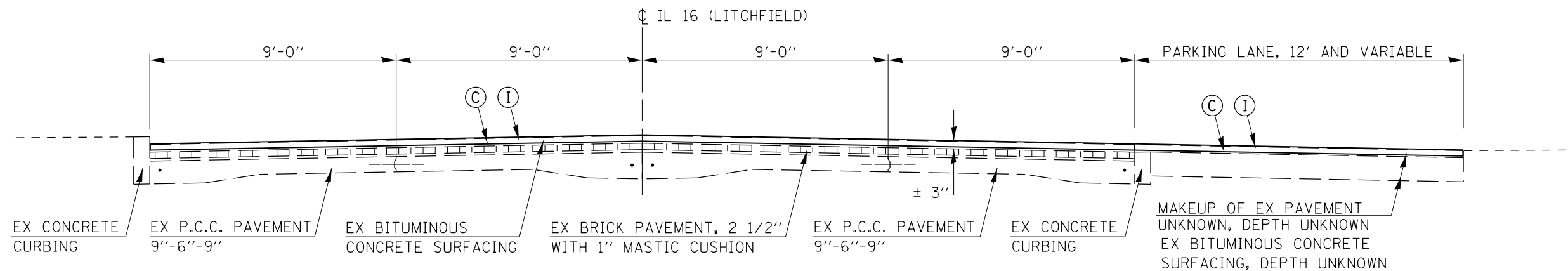

TYPICAL #F

STA. 15+73.48 TO STA. 19+97.28

-- (15, 21RS-7, 22RS-4, 24RS-8
 --- 42, 325

FILE NAME =	USER NAME = sparksgw	DESIGNED - RTS	REVISED -	STATE OF ILLINOIS DEPARTMENT OF TRANSPORTATION	TYPICAL CROSS SECTIONS (LITCHFIELD)			F.A.P. RTE.	SECTION	COUNTY	TOTAL SHEETS	SHEET NO.	
et:\pw\work\p\idot\sparksgw\10222005\0672067-sht-typical.dgn		DRAWN - RTS	REVISED -		SCALE:	SHEET NO. 3 OF 11 SHEETS	STA.	TO STA.	..	.	MONTGOMERY	80	9
		CHECKED -	REVISED -								CONTRACT NO. 72D67		
		DATE - 4-26-11	REVISED -						FED. ROAD DIST. NO.	ILLINOIS	FED. AID PROJECT		