

PLAN

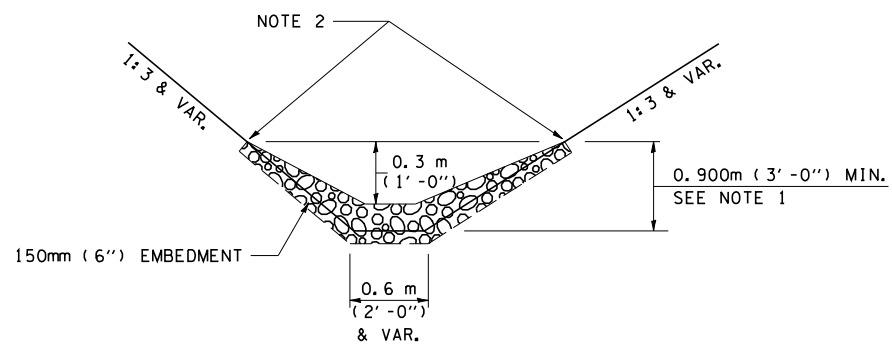

ELEVATION

OPTION 1

(EXTRUDING DITCH CHECK)  
RECOMMENDED FOR AREAS  
W/ RIPRAP DITCH LINING

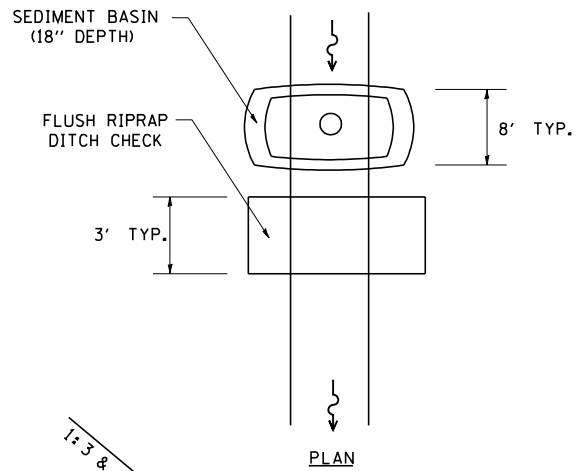

PLAN

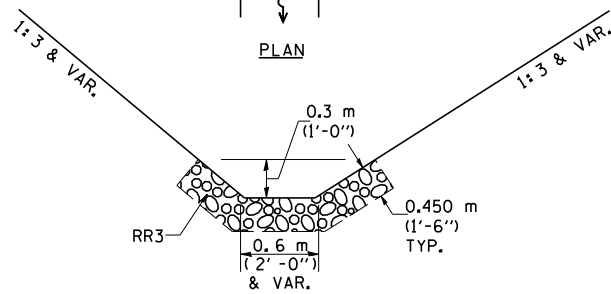

ELEVATION

OPTION 2

(FLUSH DITCH CHECK)  
RECOMMENDED FOR AREAS  
W/O RIPRAP DITCH LINING

**STONE DUMPED RIPRAP DITCH CHECK**  
(TYPICAL & OPTIONS 1 & 2  
AS DIRECTED BY THE ENGINEER)

NOTE 1: RIPRAP SHALL EXTEND FAR ENOUGH UP THE SLOPES TO ALLOW 0.3m (1') OVERTOPPING TO AVOID ERODING AROUND THE EDGES OF THE RIPRAP.

NOTE 2: ENDS SHALL BE TIED INTO SLOPES.

LEGEND FOR STORM WATER POLLUTION PREVENTION PLAN	
ITEM	SYMBOL
AGGREGATE (EROSION CONTROL) [STONE DUMPED RIPRAP DITCH CHECKS: Height = 0.6m (2') ]	
TEMPORARY DITCH CHECKS	
INLET PIPE PROTECTION (I&PP)	
PERIMETER EROSION BARRIER	
EARTH EXCAVATION FOR EROSION CONTROL (SEDIMENT BASINS)	
PRESERVE EXISTING TREES, WOODLANDS, AND UNDERSTORY (OUTSIDE CONSTRUCTION LIMITS)	
ITEM PLACED AT BEGINNING OF CONSTRUCTION (Requirement)	
ITEM PLACED AS DIRECTED BY ENGINEER (When required by situation)	
DIRECTION OF OVERLAND FLOW	

GENERAL NOTES:

All items shall be constructed as shown on this sheet, on Standard 280001, and as directed by the Engineer.

The symbology on the STORM WATER POLLUTION PREVENTION PLAN sheets does not represent the size or quantity of bales, for number of bales refer to details and notes shown on this sheet and/or as directed by the Engineer.

**THE CONTRACTOR SHALL INSTALL DITCH CHECKS AS DIRECTED BY THE ENGINEER. IF THE ENGINEER ELECTS TO UTILIZE FLUSH RIPRAP DITCH CHECKS IN LIEU OF TEMPORARY DITCH CHECKS AS SHOWN ON THE FOLLOWING PLAN SHEETS, THE SPACING SHOULD BE DOUBLED.**