

SECTION B-B
CONCRETE REMOVAL DETAIL

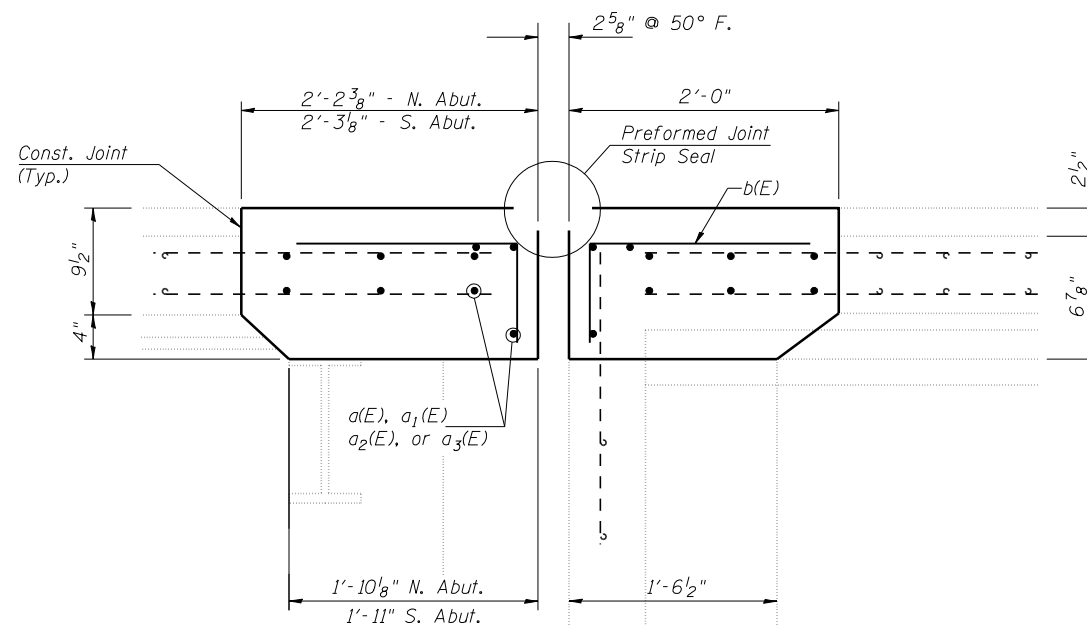

JOINT RECONSTRUCTION FOR STEEL BEAMS

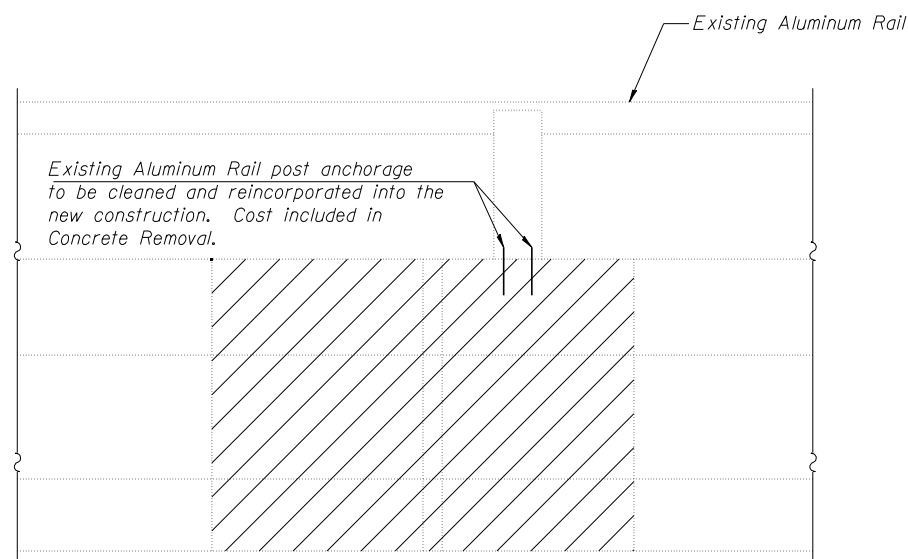

OUTSIDE ELEVATION OF PARAPET

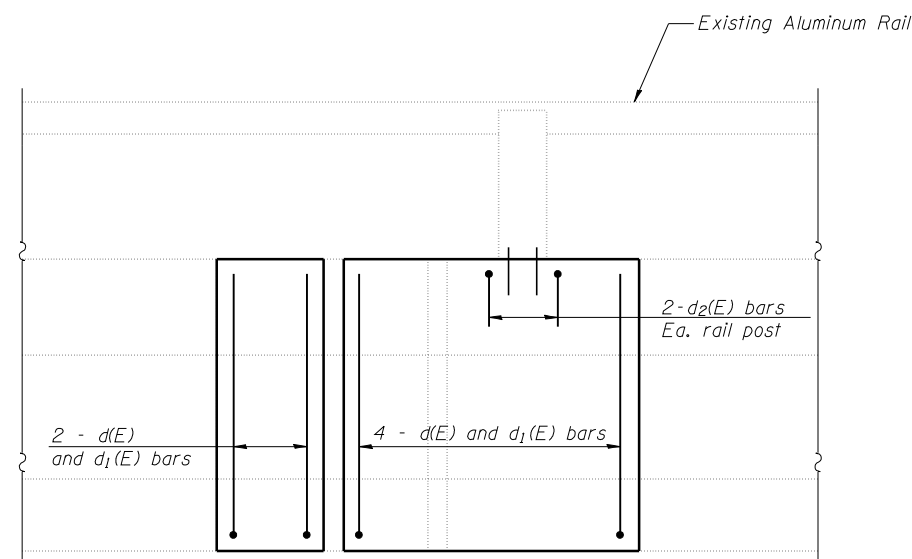

OUTSIDE ELEVATION OF PARAPET

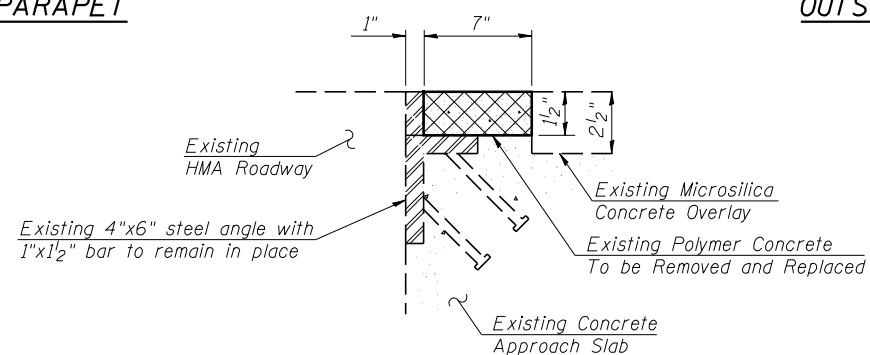

SECTION C-C
(North and South Approach Bents)

Note: Cross-hatched areas indicate limits of Concrete Removal.

Existing longitudinal reinforcement bars in the area of slab removal and existing transverse reinforcement bars projecting from the curb or parapet shall be cleaned and incorporated into the new construction.

Any reinforcement bars that are damaged during concrete removal operations shall be repaired or replaced using an approved bar splicer or anchorage system. Cost included with CONCRETE REMOVAL.