

INTERIOR GIRDER REACTION TABLE

Location	R _Q
E. Abut. S.B., W. Abut. N.B.	61 k
Pier 3 S.B., Pier 2 N.B.	61 k
Minimum Jack Capacity	50 Tons

INTERIOR GIRDER REACTION TABLE

Location	R _Q
W. Abut. S.B., E. Abut. N.B.	58 k
Minimum Jack Capacity	45 Tons

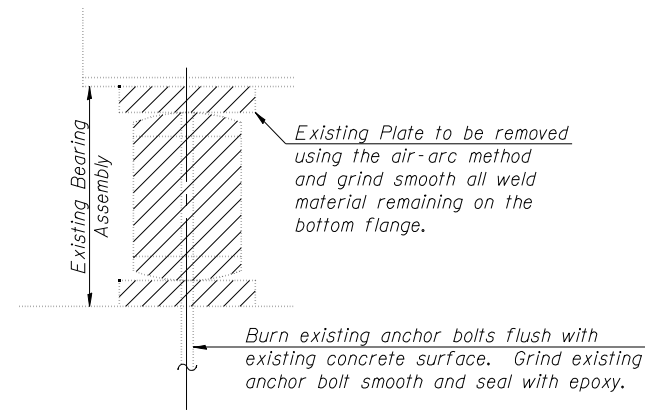

EXISTING BEARING REMOVAL DETAIL

Cost Included with "Jack and Remove Existing Bearings" at Abutment bearing removal locations and with "Removal of Existing Bearings" at Pier bearing removal locations.

BILL OF MATERIAL

Item	Unit	Total
Jack and Remove Existing Bearings	Each	24
Removal of Existing Bearings	Each	24